

Preface

Thanks for using the products of Suzhou Monarch Control Technology Co., Ltd. ME320L (N) is a new generation of elevator specialized vector control inverter, which is under the research and development of Suzhou Monarch Control Technology Co., Ltd. It's the result of many years' experience in elevator area, motor vector control and advanced algorithms like smooth curve calculation, It's the most practical, professional and easiest to use specialized inverter! Its main features are as follows:

- Applies to the driving control of permanent-magnet synchronous motor and asynchronous motor, possessing different kinds of rotary encoder interfaces;
- Self-tuning function of motor parameters, including static tuning and full tuning;
- Quick startup of curve processing, multi-stage S curve settings and 4-stage acceleration and deceleration time settings ensure the sense of comfort during the running of the elevator;
- Simple and practical battery running function, the input of 48V power supply can complete self-help when power is off;
- Enable inspection、brake contactor control, output contactor control, forced deceleration judgment, over speed testing, speed deviation testing, advanced door open, contact conglutination testing, motor overheat testing, startup pre-torque compensation and other elevator special functions make elevator control easier;
- The unique one-button design on the operation panel make complicated keyboard operation easy; that it can be put anywhere through RJ45 terminal make elevator adjustment convenient and simple; parameter copy unit make batch adjustment easy;
- Built-in DC reactor and braking unit improve output power factor of the system and reduce the cost of outside components of the electrical system;
- The whole series of independent duct design, professional lightning protection design, professional manufacture platform and advanced processs control ensure the quality of ME320L(N) specialized inverter;
- Please read and master this operating instruction, which is the attachment

of the inverter, before using ME320L(N) inverter, and keep the instruction well after reading.

The content of the manual has been conformed before print. However, our company is devoted to perfecting and improving the products, so we keep the right of revising product specifications, performance and other parts of the manual. Sorry for no special notification if there're any changes.

Suzhou Monarch Control Technology Co., Ltd provides all-round technical support for customers. If there're any questions, please contact Product Sales Center or Customer Service Center of Monarch.

Contents

PREFACE	1
CHAPTER 1 SAFETY INFORMATION AND NOTES	- 1 -
1.1 Safety Items.....	- 1 -
CHAPTER 2 PRODUCT INFORMATION	- 9 -
2.1 Naming rules.....	- 9 -
2.2 Nameplate.....	- 9 -
2.3 Main models of ME320L(N) inverters (Including IP model)	- 10 -
2.4 Technical Specification.....	- 10 -
2.5 Product figure and stallion hole size (IP model included)	- 12 -
2.6 Options (IP model included)	- 15 -
2.7 Daily maintenance of inverter	- 15 -
CHAPTER 3 INSTALLATION AND WIRING	- 21 -
3.1 Mechanical Installation	- 21 -
3.2 Electric Installation	- 23 -
CHAPTER 4 OPERATION AND TEST-RUN OF THE INVERTER	- 41 -
4.1 Terms of ME320L(N) Inverter	- 41 -
4.2 Introduction of operation and display panel.....	- 42 -
4.3 Function codes examination and operation instruction	- 43 -
4.4 Operation of shortcut menu	- 45 -
4.5 Password setting	- 47 -
4.6 Motor parameter self-tuning.....	- 47 -
CHAPTER 5 FUNCTION PRAMETER TABLE	- 49 -
5.1 Function Parameter Table.....	- 49 -
5.2 Function Groups.....	- 49 -
CHAPTER 6 FUNCTION PARAMETER SPECIFICATION	- 65 -
6.1 F0 Basic Parameters.....	- 65 -
6.2 F1 Group Motor parameters	- 67 -
6.3 F2 Vector control factors.....	- 70 -
6.4 F3 Startup/stop control parameters	- 72 -
6.5 F4 Group Input terminal.....	- 77 -

6.6 F5 Group	Output terminal	- 79 -
6.7 F6 Group	Speed parameters	- 82 -
6.8 F7 Group	Curve parameters	- 86 -
6.9 F8 Group	Keyboard parameters	- 88 -
6.10 F9 Group	Fault and protection	- 92 -
6.11 FA Group	PG parameters.....	- 95 -
6.12 FB Group	Communication parameters	- 96 -
6.13 FC Group	Special enhancement function	- 96 -
6.14 FD Group	Special function parameters.....	- 100 -
6.15 FP Group	User shortcut parameters.....	- 101 -
CHAPTER 7	APPLICATION AND ADJUSTMENT	- 103 -
7.1	Multi-stage speed control mode.....	- 103 -
7.2	Analogue control mode	- 109 -
7.3	Inspection running	- 111 -
7.4	Power failure emergency running.....	- 113 -
7.5	Analogue weighing adjustment.....	- 116 -
7.6	Weighingless adjustment method	- 118 -
CHAPTER 8	FAULTS-CAUSES-REMEDIES	- 121 -
8.1	Fault alarm and remedies.....	- 121 -
8.2	Common faults and remedies	- 121 -



Safety Information and Notes

Chapter 1 Safety information and Notes

Safety definition:

There are two kinds of safety items in this manual:



Failure to follow the instructions will result in death or serious injury.



Failure to follow these instructions can result in medium hurt or equipment damage.

Please read this manual carefully and operate strictly according to the safety tips while installing, debugging, maintaining the system. MONARCH Company is free of charge to any damage or loss caused by any operations that not performed according to the requirements.

1.1 Safety Items

1.1.1 Before Installation

**Danger**

- Do not install in the condition of components scarcity or damage! Cautious for the danger of getting hurt!

1.1.2 During Installation

**Danger**

- Please mount the inverter on incombustible surface like metal, and keep away from flammable substances! Otherwise it may cause fire!

**Note**

- When more than 2 inverters in one cupboard, pay attention to the installation position to ensure heat dissipation.
- Do not let wiring terminal or screw enter the controller, otherwise the inverter will be damaged!
- Install the inverter where there's less shaking and no direct sunshine.

1.1.3 Wiring

 Danger
<ul style="list-style-type: none">● Only the qualified electrical engineer can perform the wiring, otherwise there will be danger of electric shock.● A circuit breaker must be installed between the power supply and the inverter; otherwise there will be danger of fire.● Wiring can only be done after the power is cut off; otherwise there will be danger of electric shock.● Please connect the inverter to the ground according to the requirements, otherwise it will be dangerous

 Danger
<ul style="list-style-type: none">● Do not connect the input current with the inverter's output terminals (U, V, W). Please note the marks and do not connect the wrong wires otherwise the controller may be damaged!● Ensure the wiring meet the EMC requirements and the local safety standard. The wire size shall be determined according to the manual, otherwise accidents may occur!● Brake resistor can never be connected between the DC bus terminals (+) and (-) directly, otherwise fire may occur!

1.1.4 Before Power-on

 Note
<ul style="list-style-type: none">● Please confirm the mains voltage level is consistent with that of the inverter ;the input (R,S,T) and output (U,V,W) wirings are correct; and check if there is any short circuit in peripheral circuit and if the wiring is fixed and fast; otherwise the inverter may be damaged!● No part of controller needs further dielectric strength testing since it has been done in the factory; Otherwise accidents will occur!

 Danger
Mount the cover plate properly before power-on the inverter; otherwise there will be danger of electric shock!
<ul style="list-style-type: none">● All the external parts wirings must be connected according to the instruction of this manual, otherwise accidents may occur!

1.1.5 After Power-on



Danger

- Do not open the cover of the controller after power-on, otherwise there will be danger of electric shock!
- Do not touch the controller and its circuit with wet hand; otherwise there will be danger of electric shock.
- Do not touch the controller terminals; otherwise there will be danger of electric shock.
- At power-on, the controller will perform the security check of the external heavy-current circuit. At this time do not touch U, V, W terminals of controller or the wirings terminals of the motor; otherwise there will be danger of electric shock!



Danger

- If parameter identification is required, please pay attention that the rotating motor may injure people, otherwise accident may occur!
- Do not change the factory settings; otherwise the equipment may be damaged!

1.1.6 Running



Danger

- Do not touch the fan and the discharging resistor to check the temperature, otherwise burning will occur!
- Only the qualified technician can check the signal while it's running. Otherwise there will be danger of personal injury or equipment damage!



Note

- Do not let objects fall in a running inverter; otherwise the inverter may be damaged!
- Do not start and stop the controller by on/off of the contactor, otherwise the inverter may be dangerous.

1.1.7 Maintenance



Danger

- Please do not repair or maintain the inverters with power on, otherwise there will be danger of electric shock!
- Ensure the repair and maintenance of the inverter is operated in the condition that the CHARDE light of inverter is off. Otherwise the residual Charge in the capacitor will injure people.
- Only qualified electrical engineer can repair or maintain the controller, otherwise there will be danger of human injury or damaging the equipment.

1.2 Precautions

1.2.1 Motor insulation check

When the motor is used for the first time, or reused after storing for a long time, or in a regular checkup, the user must check the insulation of the motor to prevent the poor insulation of the windings of motor from damaging the controller. The motor connection must be divided from the controller during the insulation check. It is recommended to use a 500V Mega-Ohm-Meter to check and the insulation resistance shall not be less than 5MΩ.

1.2.2 Thermal Protection of Motor

If the rated capacity of the motor selected is not matching that of the inverter, especially when the rated power of the inverter is bigger than that of the motor, make sure to adjust the parameters for motor protection inside the inverter or to install a thermal relay to the motor to guarantee the protection to the motor.

1.2.3 Over Work Frequency Running

The inverter should not be used under over work frequency. If the frequency is over 50HZ, mechanical parts of the elevator cannot bear it, and it will affect the life of the inverter.

1.2.4 Motor Heat and Noise

Since the output voltage of the inverter is in PWM wave with some harmonic wave, the temperature may raise, the noise and vibration may increase compared with the inverter running at main frequency.

1.2.5 Pressure-sensitive Device or Capacitor at the Output Side of the Inverter

Because the inverter outputs PWM wave, the capacitor used for improving power factor and pressure-sensitive resistor used for lightning-proof shouldn't be installed at the output side of the controller. Otherwise the inverter may have transient over-current and may be damaged.

1.2.6 Switches Used at the Input and Output terminal of the Inverter

If the contactor is required to be installed between the inverter input terminal and the power supply, it is prohibited to start or stop the inverter with the contactor. If the switches like contactors are connected between the output terminal and the motor, make sure to start and stop the inverter when the inverter has no outputting, otherwise the modules in the inverter may be damaged.

1.2.7 Usage out of the Range of Rated Voltage

The ME320L(N) Inverter shall not be used out of the specified range of operation voltage. Otherwise the internal components of the inverter may be damaged. If needed, please use corresponding voltage regulation device to change the voltage.

1.2.8 Change from 3-phase to 2-phase

3-phase inverter should not be used as 2-phase, otherwise, it will result in faults or the damage of the inverter.

1.2.9 Lightning Strike Protection

There are lightning protection devices inside the inverter, but the user should install other lightning protection device at the front end of the inverter if lightning strike occurs frequently.

1.2.10 Altitude and De-rating

When the altitude is higher than 1000m, the cooling effect of inverter is deteriorated because of the rarefaction of air, then it is a necessity to derate the use of inverter and please contact our company for detailed technical support in this circumstance.

1.2.11 Some Special Usage

Please consult our company if you want to apply other wiring ways, which are not suggested in the manual.

1.2.12 Cautions for Scrap of controller

The electrolytic capacitors in the main circuits and PCB may explode when they are burned and poisonous gas may be generated when the plastic parts are burned. Please dispose the controller as industrial rubbish.

1.2.13 About Applicable Motor

1) ME series inverter is applicable to 4-pole squirrel-cage Asynchronous motor. IP model is applicable to permanent-magnet Synchronous motor. Please make sure that the rated current of the motor is applicable to the inverter.

2) The cooling fan and rotor shaft of non-inverter motor are connected by one rotor, cooling effect gets bad when the rotation speed reduces, so forced ventilating fan should be installed or non-inverter motor should be transferred into inverter motor when the motor is over-heated.

3) The inverter for Asynchronous motor has already been configured with motor parameters. It's necessary to perform the motor parameter identification or revise the default according to the actual conditions; otherwise, the operation effect and protection performance will be affected. Permanent-magnet Synchronous motor must carry out parameter identification.

4) As short-circuit in cables or motor can result in the inverter alarming, even explosion. Therefore, before Power-on and maintenance we must execute short-circuit-test for new elevator. Please make sure that the inverter be cut from the testing parts when the testing is undergoing.



Product information

Chapter 2 Product Information

This chapter introduces the related information, daily use and maintenance and product choosing instructions of ME320L(N) elevator specialized inverter. It's helpful for the safe application of the product.

2.1 Naming rules

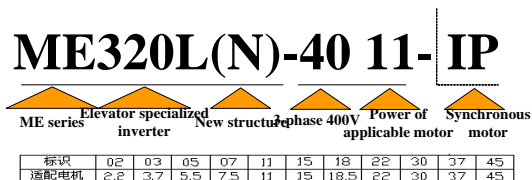

Fig 2-1 Naming rules

2.2 Nameplate

Nameplate of ME320L(N) inverter applicable to Asynchronous motor:

MODLE	ME320L (N) -4011
POWER	11kW
INPUT	3PH AC380V 29A 50Hz/60Hz
OUTPUT	3PH AC380V 27A 0~90Hz
S/N	

Fig 2-2 Nameplate 1

Nameplate of ME320L(N)-IP inverter applicable to permanent-magnet synchronous motor:

MODLE	ME320L (N) -4011-IP
POWER	11kW
INPUT	3PH AC380V 29A 50Hz/60Hz
OUTPUT	3PH AC380V 27A 0~90Hz
S/N	

Fig 2-3 Nameplate 2

2.3 Main models of ME320L(N) inverters (Including IP model)

Table 2-1 Models

Inverter model	Power volume kVA	Input current A	Output current A	Applicable motor kW
3-phase 380V Range: -15%~20%				
ME320L(N)-4002	4.0	5.8	5.1	2.2
ME320L(N)-4003	5.9	10.5	9.0	3.7
ME320L(N)-4005	8.9	14.6	13.0	5.5
ME320L(N)-4007	11.0	20.5	18.0	7.5
ME320L(N)-4011	17.0	29.0	27.0	11
ME320L(N)-4015	21.0	36.0	33.0	15
ME320L(N)-4018	24.0	41.0	39.0	18.5
ME320L(N)-4022	30.0	49.5	48.0	22
ME320L(N)-4030	40.0	62.0	60.0	30
ME320L(N)-4037	57.0	77.0	75.0	37
ME320L(N)-4045	69.0	93.0	91.0	45

2.4 Technical Specification

Table 2-2 Technical Specifications

Item	Specification		
Basic specification	Carrier frequency	0.5k~16k(Hz) ; Carrier frequency can be adjusted automatically according to the load characteristic.	
	Input frequency resolution	Data setting: 0.01Hz Analog setting: highest frequency×0.1%	
	Output frequency accuracy	Data setting: highest frequency×±0.01% Analog setting: highest frequency×±0.01%	
	Control mode	Split-ring vector control (SVC)/ Closed loop vector control (VC)	
	Startup torque	0.5Hz/180% (SVC) ; 0Hz/200% (VC)	
	Speed control range	1: 100 (SVC)	1: 1000 (VC)
	Speed accuracy	±0.5% (SVC)	±0.05% (VC)
	Overload capability	150% rated current for 60 seconds; 180% rated current for 1 second.	
	Speed up and speed down curve	Straight line or S curve acceleration and deceleration way; 4 group acceleration and deceleration time and S curve settings; various combinations	
	Testing and mending control	Can be appointed by any multi-stage speed	
	Multi-stage running	Realize at least 8 stage speed	

	Item	Specification
Display and operation	Automatic voltage regulation (AVR)	Keep output voltage permanent, when network voltage changes
	LED display	Display setting frequency, output frequency, output voltage, output current and other parameters
	LCD display operating panel	Choose parts, operation tips in Chinese/English
	Parameter copy	LCD operating panel makes a copy of parameters quickly
	Protection function	Provide 40 kinds of protection such as electrify short circuit survey, in-out lack phase protection, over current protection, over voltage protection, undervoltage protection etc.
	Key lock and function choosing	Set partial or complete lock of the keys; define function range of part of the keys to avoid misoperation
Special function	Electrify peripheral equipment safety self-examination	Implement electrify and do peripheral equipment detection like grounding, short circuit etc.
	Blackout emergency function	The realization of emergency project is easy and convenient
	Over speed protection	Elevator over speed protection function built in; various operation choices
	Judgment of speed deviation	Speed deviation testing function built in to find out potential risks in time
	Forced speed changing function	Effectively avoid hoisting and resting of the elevator
	Motor temperature testing	Judge the temperature of the motor in time and eliminate potential risks
	Startup compensation	Two ways of startup torque compensation: analogue or digit
	QUICK key	Customers can define shortcut menu freely
	Timing control	Convenient for timing
Input/output characteristi	Running order channel	Three channels: decided by operation panel, control terminal, communication
	Frequency source	Five frequency source: decided by digit, analogue voltage, analogue current, communication, multi-stage speed
	Input terminal	10-path digit input terminal, 1 path of it can be used as high-speed pulse input, which is compatible to PNP or NPN 3-path analogue input terminal, 1 path of it can only be used as voltage input, another one can be used as voltage or current input.

Item		Specification
	Output terminal	3-path digit output terminal 2-path relay output terminal 2-path analogue output terminal, 0/4~20mA or 0/2~10V can be chosen, can realize the output of setting frequency, output frequency and other physical quantities
Circumstance	Altitude	Lower than 1000 meters
	Surrounding temperature	-10℃~+40℃ (when within 40℃~50℃, derating is required)
	Humidity	Less than 95%RH, no condensation
	Vibration	Less than 5.9 m/s ² (0.6g)
	Storage temperature	-20℃~+60℃

2.5 Product figure and stallation hole size (IP model included)

2.5.1 ME320L Product figure:

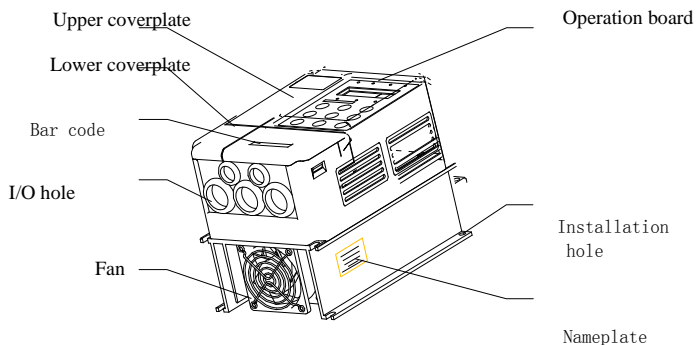

Fig 2-4 ME320L Figure of Inverter

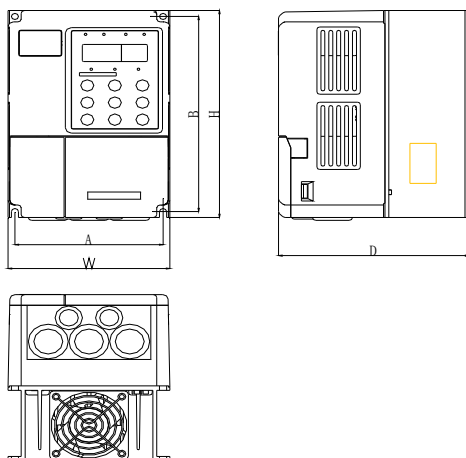

Fig 2-5 ME320L Size of inverter and Installation sizes

2.5.2 ME320L Installation hole sizes (IP model included)

Table 2-3 Installation sizes

Inverter model	A mm	B mm	H mm	W mm	D mm	Hole size mm	Gross weight kg
ME320L-4002	113	172	182	123	145	φ5.4	1.7
ME320L-4003	148	236	246	158	165	φ5.4	4
ME320L-4005							
ME320L-4007	150	335	348	223	177	φ6.5	10
ME320L-4011							
ME320L-4015							
ME320L-4018	235	447	460	285	220	φ6.5	14
ME320L-4022							
ME320L-4030							
ME320L-4037	250	598	650	396	262	φ10	25
ME320L-4045							

2.5.3 ME320LN figure:

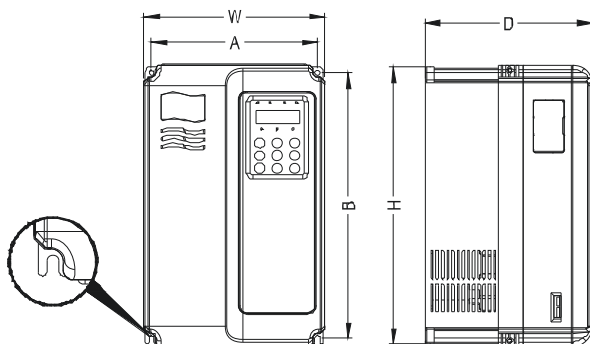

Fig 2-6 ME320LN Inverter (2.2kW~15kW) figure and Installation sizes

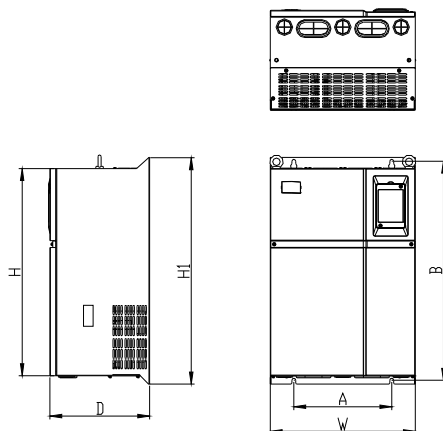

Fig 2-7 ME320LN Inverter (18.5kW~45kW) figure and Installation sizes

2.5.4 ME320LN Installation hole sizes (IP model included)

Table 2-4 Installation sizes

Inverter model	A mm	B mm	H mm	H1 mm	W mm	D mm	Size mm	Gross weight kg
ME320LN-4002	113	172	186	/	125	164	φ5.0	1.1
ME320LN-4003	148	236	248	/	160	183	φ5.0	2.5
ME320LN-4005								

Inverter model	A mm	B mm	H mm	H1 mm	W mm	D mm	Size mm	Gross weight kg
ME320LN-4007	190	305	322	/	208	192	φ6	6.5
ME320LN-4011								
ME320LN-4015								
ME320LN-4018	235	447	432	463	285	228	Φ8	20
ME320LN-4022								
ME320LN-4030								
ME320LN-4037	260	580	549	600	385	265	Φ10	32
ME320LN-4045								

2.6 Options (IP model included)

Table2-5 Option

Name	Model	Function	Remarks
PG card	MCTC-PG-A	Rotary encoder interface card Divider output card	Provide 5V power, push-pull or open-collector output incremental encoder; Divider is optional;
	MCTC-PG-B	Rotary encoder interface card Divider output card	Provide 5V power, long-term drive incremental encoder, U V W encoder; Divider 1 only;
	MCTC-PG-C	Rotary encoder interface card Divider output card	Provide 5V power, sin、cos encoder
Parameter Copy Unit	ME-CP	Parameter Copy	Generic RJ45 interface applied
Outside lead LED operation panel	MDKE	Outside lead LED display and operation keyboard	RJ45 interface applied, for ultra-long-distance use
Extension cable	MDCAB	Standard 8-core cable	Provide 1-meter, 3-meter and others

Detailed function of options and operation instructions refer to corresponding option explanation.

If upper options need, please note when ordering.

2.7 Daily maintenance of inverter

2.7.1 Daily maintenance

The influence of the environmental temperature, humidity, dust and vibration

will result in the aging and wearing of the components in the inverter, which will give rise to the occurrence of potential faults and reduce the life of inverter. Therefore, it is quite necessary to do the work of daily maintenance of inverter.

**Danger**

The filter capacitor still has high voltage after the power supply to the inverter is switched off, so do not maintain or repair the inverter until the bus voltage measured after the CHARGE light is off with the multi-meter. The voltage must be lower than 36V.

1) Daily checking items:

- a) Check if there is any abnormal noise during the running of motor;
- b) Check if there is any vibration of motor ;
- c) Check if the installation environment of inverter changes ;
- d) Check if the cooling fan of inverter works normally;
- e) Check if the inverter is over heated.

2) Daily Cleaning:

- a) Keep the inverter in a clean status;
- b) Clean the dust from the inverter and prevent the dust especially the metal powder from entering the inverter;
- c) Clean the oil dirt in the cooling fan of the inverter

2.7.2 Periodical Checking

Periodically check the places that are hardly checked during the running.

1) Periodical Checking Items:

- a) Check the ventilation channels and clean them periodically;
- b) Check if the screws are loose;
- c) Check if the inverter is rusted;
- d) Check if the input / output terminals has scratch marks;
- e) Check the insulating in main circuit.

**Note**

Insulation test (use 500V Mega-Ohm-Meter) should be done separately after disconnecting the input power cables from the inverter; or else, the inverter will be damaged. Do not use the insulated Ohm-Meter to test the insulation of control circuits. Dielectric strength test had been done at factory. Therefore, user need not do this test again.

2.7.3 Replacement of Wearing Parts

The wearing parts of inverter mainly include the cooling fan and filtering

electrolytic capacitor. Their lifetime is closely related to the operating environment and maintenance.

General lifetime as follows:

Component	Life time	Cause	Standard of judgment
Colling fan	2~3 years	Shaft bearing wear, aging of blades	No crack on fan blade, no abnormal vibration noise at start
Filtering electrolytic capacitor	4~5 years	Poor quality of input power, high environmental temperature, frequent load jump, electrolyte aging	No liquid leak, no protrusion of safety valve, electrostatic capacitance measurement, and insulation resistance measurement.

2.7.4 Storage of inverter

The following points must be noticed in inverter temporary and long-term storage:

- 1) It is recommended to store the inverter in its original packing box.
- 2) Long-term storage will cause deterioration of electrolytic capacitor. Therefore, controllers not in service for a long time must be powered for at least once within 2 years for testing purpose, at least for 5 hours ; in the test , the input voltage must be boosted gradually with voltage regulator to the rated value.

2.8 Warranty Description of Inverter

Free warranty is only for the inverter itself.

- 1) Our company promise 18-month warranty (from the day of manufacture displayed by bar code) when there are faults or damage under normal use. Reasonable maintenance costs will be chsrge when time is over 18 months;
- 2) During the 18 months, reasonable maintenance costs will be charged when following situation appear:
 - a) Damage caused by not following the regulations in the manual;
 - b) Damage caused by fire, flood, abnormal circuit and others;
 - c) Damage caused by applying inverter for abnormal function;

Relative charges are calculated according to the uniform standards. If there's a contract, conform to the contract first.

2.9 Model choosing of Driving Brake Resistance (IP model included)

Braking unit has been built in in ME320L(N) elevator specialized inverter with the power less than 30kw (30kW included). But braking unit and brake resistor should be mounted to inverter with the power more than 30kw.

Table 2-6 DBR

Inverter model	DBR specification	Braking unit	Applicable motor (kW)
ME320L(N)-4002(-IP)	660W, 220Ω	Standard built-in	No special explanation
ME320L(N)-4003(-IP)	1100W, 130Ω		
ME320L(N)-4005(-IP)	1600W, 90Ω		
ME320L(N)-4007(-IP)	2500W, 65Ω		
ME320L(N)-4011(-IP)	3500W, 43Ω		
ME320L(N)-4015(-IP)	4500W, 32Ω		
ME320L(N)-4018(-IP)	5500W, 25Ω		
ME320L(N)-4022(-IP)	6500W, 22Ω		
ME320L(N)-4030(-IP)	9000W, 16Ω		
ME320L(N)-4037(-IP)	11000W, 13Ω	External	
ME320L(N)-4045(-IP)	13500W, 10Ω		

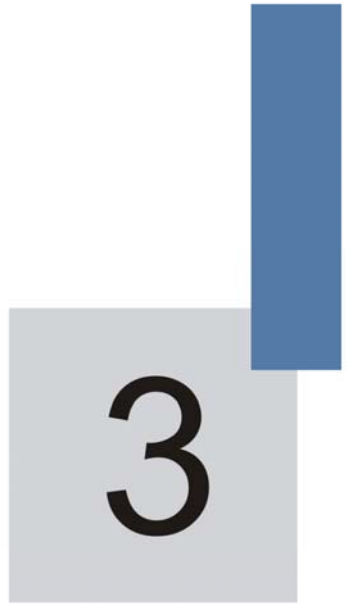

Installation and Wiring

Chapter 3 Installation and wiring

Before installation, when opening the package, must check to make sure:

Nameplate and rated power of the inverter is the same with the one you order; ordered inverter, product certificate, user manual and guarantee statement are included in the case.

There's no damage of the product caused by transporting; if there's any item lost or damaged, contact our company or agent as soon as possible.



Note

Please follow the Notes in Chapter One during the installation and wiring of the inverter.

3.1 Mechanical Installation

3.1.1 Installation environment:

- 1) Temperature :surrounding temperature has a big effect on the life time of the inverter, the permitted temperature range is $-10^{\circ}\text{C} \sim 50^{\circ}\text{C}$.
- 2) Inverter should be mounted on the surface of fire retardant substances, and enough room for heat dissipation must be ensured as inverter working brings a large quantity of heat. Inverter should be vertically installed on the support.
- 3) Install the inverter where vibration rarely happens, vibration cannot be stronger than 0.6G, especially the place which is far away from the equipment like punching machine.
- 4) Install the inverter where there's no direct sunshine, humidity or bead.
- 5) Install the inverter where there's no corrosive,flammable and explosive gas in the air.
- 6) Avoid installing inverter where there's much oil, dust and metal powder.

3.1.2 Tips of Installation position

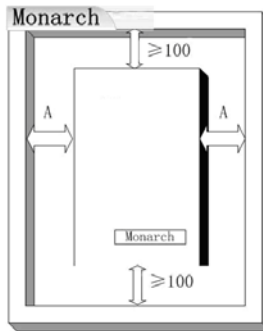

Fig 3-1 Installation Position

Explanation: The size of A cannot be considered if the power is not bigger than 22kW, otherwise, the size of A should be larger than 50mm.

The concern of mechanical installation is heat dissipation, so please pay attention to the following:

- 1) Please install the inverter vertically, which helps heat dissipate upward. It cannot be put upside down.
- 2) Installation position should be like that in the picture to ensure the room for heat dissipation. At the same time heat dissipation of other parts in the cupboard should be considered.
- 3) The support must be made of non-flammable material.
- 4) The room for heat dissipation must be large enough when the cupboard must be sealed because of dust.

3.1.3 Teardown and installation of the coverplate

- 1) The ME series inverter (under 15kw) adopts plastic shell, teardown and installation of its bottom coverplate refer to Picture 3-2.
 - a) Teardown: Find the pothooks under the plate, and push towards inside, using tools.
 - b) Installation: First, put the upside meatus (at the down cover plate) into the apertures (at the up cover plate), then press forcibly downwards until hearing the sound of "chatter".

The body of the plastic shell shouldn't be teared down, if repairing needed, please contact our company.

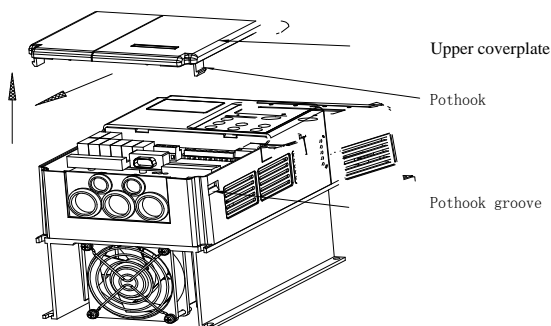

Fig 3-2 ME320L Teardown and installation of lower plastic coverplate

- 2) The ME series inverter (above 18.5kw) adopts sheetmetal shell, teardown procedure of its upper coverplate is as follows:
 - a) Loosen the bolts on the coverplate directly with implements;
 - b) Raise it upward slightly;
 - c) Draw it out gently.

Installation of the upper coverplate is just the opposite way with teardown.

Note: Avoid the dropping of the upper coverplate during dismantling, which will cause hurt to the equipment or people.

3.2 Electric Installation

3.2.1 Choosing of External device (IP model included)

Table 3-1 ME320L (N) Inverter External device choosing

Inverter model	Air circuit breaker (MCCB) A	Contact A	Input side main circuit lead mm ²	Output side main circuit lead mm ²	Control circuit lead mm ²	Grounding wire mm ²
ME320L(N)-4002	16	10	2.5	2.5	0.75	2.5
ME320L(N)-4003	25	16	4	4	0.75	2.5
ME320L(N)-4005	32	25	6	6	1	4
ME320L(N)-4007	40	32	6	6	1	4
ME320L(N)-4011	63	40	6	6	1	4
ME320L(N)-4015	63	40	6	6	1	4
ME320L(N)-4018	100	63	10	10	1	4
ME320L(N)-4022	100	63	10	10	1	4
ME320L(N)-4030	125	100	16	16	1	4

Inverter model	Air circuit breaker (MCCB) A	Contact or A	Input side main circuit lead mm ²	Output side main circuit lead mm ²	Control circuit lead mm ²	Grounding wire mm ²
ME320L(N)-4037	160	100	16	16	1	4
ME320L(N)-4045	200	125	25	25	1	4

3.2.2 Using of External device:

Table 3-2 ME320L (N) Inverter External device Using

Device	Position	Function
Air braker	Front end of input circuit	Cut off the power and provide short protection. This breaker must be used.
Contact or	Between air breaker and input side of the inverter	Switch on/off the inverter. Frequent power-on and power-off or direct startup and stop controls of the inverter should not be performed through contact or.
AC input reactor	Inverter input side	<p>1) Improve input power factor;</p> <p>2) Eliminate high-frequency harmonics in input side;</p> <p>3) Eliminate current unbalance caused by input phase unbalance.</p> <p>When DC reactor cannot meet the requirements, change it into AC reactor.</p>
DC reactor	For ME320L(N) Inverter (7.5kW~45kW) DC reactor is standard built in	<p>1) Improve input power factor;</p> <p>2) Eliminate high-frequency harmonics in input side;</p> <p>3) Eliminate current unbalance caused by input phase unbalance to a certain extent, but not as well as AC reactor.</p> <p>DC reactor is suggested for its small volume and generating no buck in circuit. Our company applies DC reactor as standard built-in.</p>
AC output reactor	Between inverter output side and motor, near inverter	Usually when the distance between inverter and motor is more than 100m, AC output reactor is better to be installed.

3.2.3 Electric wiring

**Danger**

Make sure the power is OFF before wiring. Otherwise, shock may happen!
Only qualified trained engineer can wire the inverter, otherwise there will be danger of human injury or damaging the equipment!
Grounding must be reliable, otherwise there will be the danger of shock and fire!
Brake resistor can never be connected between the DC bus terminals (+) and (-) directly, otherwise serious accident will happen!

**Danger**

Make sure the input power is the same with the provided power, otherwise it will damage the inverter!
Make sure the motor is applicable to the inverter, otherwise the motor will be damaged or it will cause inverter protection!
Do not connect the input current with the terminals (U, V, W), otherwise the inverter will be damaged!

- 1) Wiring way (IP included)

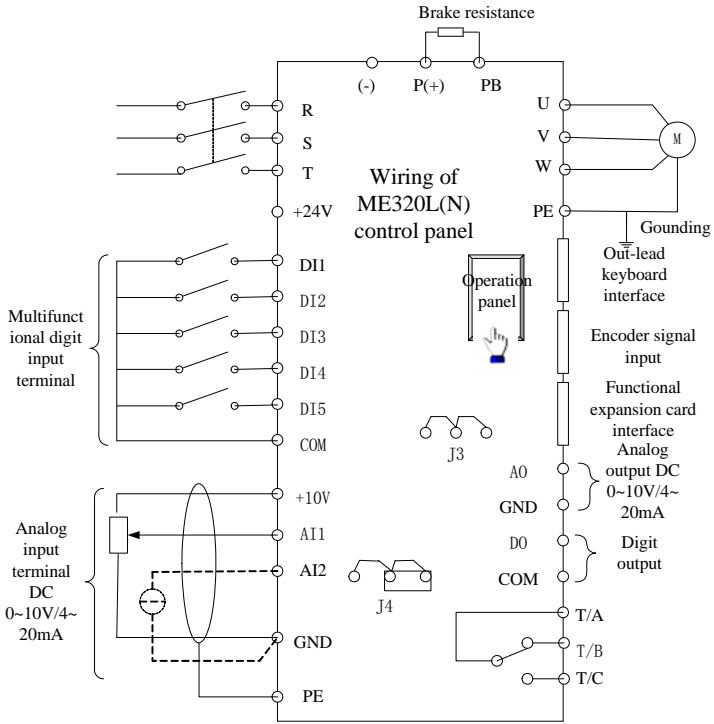

Fig 3-3 Applicable to ME320L(N)-4002~ME320L(N)-4045 inverter

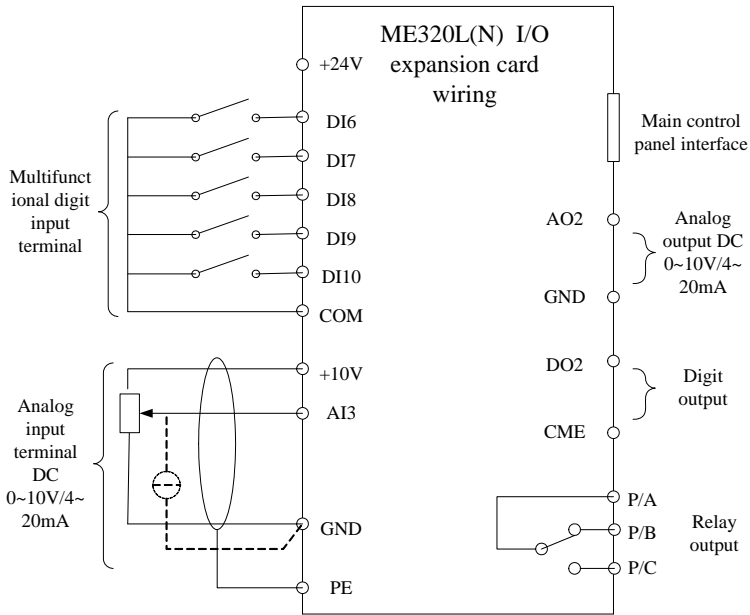

Fig 3-4 ME320L(N) Inverter I/O Expansion board wiring

2) Main circuit terminals and their wiring

a) Terminal function:

Table 3-3 Terminal function

Terminal	Name	Instruction
R、S、T	3-phase power input terminal	Input 3-phase AC 380V
(+)、(-)	Positive and negative terminals of DC bus	Input point of common DC, Terminal of external brake unit for inverter above 37KW.
P(+）、PB	Terminals for brake resistor	Terminal of brake unit for inverter below 30kW(include 30kW)
U、V、W	inverter output terminal	Connect 3-phase motor
PE	Terminal for grounding	Grounding terminal

b) Notes of wiring:

A、DC bus (+)、(-) terminals:

When the power is just off, the DC bus (+)、(-) terminals can be touched only

when the residual voltage on them is proved lower than 36V by multimeter after the CHARGE light is off.

In order to release the energy brought by braking process, for ME320L(N) inverter above 37kW, external braking unit need be connected to DC bus(+), (-) terminal, and brake resistor to the P, PB terminals of the braking unit. Make sure (+), (-) are not connected oppositely, otherwise it will damage the inverter, even cause fire. The wire between braking unit and DC bus (+), (-) terminal should be not longer than 5m, and that between braking unit and brake resistor should be not longer than 10m. UTP or two wires, which are tightly together, should be used.

Brake resistor mustn't be connected to DC bus, which will damage the inverter, and even cause fire.

B、 Brake resistor terminals (+)、 PB:

Braking unit has been built in in ME320L(N) inverter below 30kW. In order to release the energy brought by braking process, brake resistor must be connected to (+)、 PB.

Selecting of the brake resistor must follow the suggestion in Chapter 2.

Wire of brake resistor should be less than 5m.

The temperature of brake resistor will rise because of the released energy, so pay attention to its protection and cooling.

C、 Inverter output terminals U、 V、 W:

Output side of the inverter is connected to 3-phase motor. When the motor runs in the opposite direction, exchange any two of the U、 V、 W wires can change the running direction of the motor.

Inverter output side cannot be connected to capacitor or inrush absorber, otherwise it will result in frequent protection or damage of the inverter.

Short or grounding in the output side are absolutely prohibited.

Inverter output wires U 、 V、 W should be introduced into a metal pipe which is grounded, and should be apart from the signal cable or vertically arranged.

When the wire between motor and inverter is too long, due to the influence of the distributed capacitor, high-frequency current in the circuit will arouse resonance and then result in the damage of the motor insulation, or big leakage current will occur and lead to inverter overcurrent protection. Usually

it's not longer than 100m. it's better to install AC output reactor.

D. Grounding terminal:

Grounding terminal must be grounded well. Grounding wire should be wide and short, it's better to use special yellow-green multi-strand copper-core ground wire which is above 4mm². Make sure ground resistor is not bigger than 5Ω. Grounding pole should be separate; it cannot be shared with neutral line of power.

3) Control terminals and their wiring:

a) Main controller terminal placement:

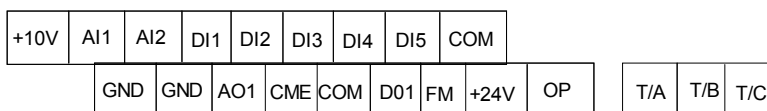

Fig 3-5 Main controller terminal placement

b) Control terminal function:

Table 3-4 Control terminal function

Sort	Terminal sign	Terminal name	Function
Power	+10V-GND	External connect+10V power	Supply +10V power , maximum output current:10mA Usually used as power for external potentiometer, resistance of the potentiometer: 1kΩ~5kΩ
	+24V-COM	External connect+24V power	Supply +24V power, usually used as power for digit input terminal and external sensor, maximum output current: 200mA
	OP	Exterior power supply input terminal	Factory default: connect +24V power When using exterior signal to drive DI1~DI5, OP should be connected to exterior power, and connection between OP and +24V power terminal should be cut.
Analogue input	AI1-GND	Analogue input terminal 1	Input power: DC 0~10V Input impedance: 100kΩ
	AI2-GND	Analogue	1、Input power: DC 0~10V/4~20mA, determined by jumper J3 of control board.

Sort	Terminal sign	Terminal name	Function
		input terminal 2	2、 Input impedance: voltage input - 100k Ω , current input - 500 Ω
Digit input terminal	DI1-COM	Digit input 1	1、 Optocoupler isolation , double polarity input compatible 2、 Input impedance: 3.3k Ω
	DI2-COM	Digit input 2	
	DI3-COM	Digit input 3	3、 input voltage range: 9V~30V Has the characteristics of DI1~DI4, and can also be used as high-speed pulse input.
	DI4-COM	Digit input 4	
	DI5-COM	Digit input 5 (high-speed pulse)	
Analogue output	AO1-GND	Analogue output 1	Output voltage or current is determined by J4 jumper on the control board. Output voltage: 0V~10V Output current: 0mA~2mA
Digit output	DO1-CME	Digit output 1	Optocoupler isolation, double-polarity open collector output Output voltage: 0V~24V Output current: 0mA~50mA Note: Digit output CME and digit input COM are isolated inside, but jump out between CME and COM is set in factory (DO1 default: +24V driven); when driving DO1 with exterior power, the outside jumper between CME and COM should be cut off.
	FM-COM	High-speed pulse output	
Relay output	T/A-T/B	Normal close Terminal	Contactor driving capacity: AC: 250V、 3A、 Cos ϕ =0.4 DC: 30V、 1A
	T/A-T/C	Normal open Terminal	
Auxiliary interface	J1	Function expansion card	28-core terminal, special interface card
	J2	PG card interface	PG card special interface
	CN3	Outside lead keyboard interface	Outside-lead keyboard, parameter-copy-unit interface

c) Expansion card terminal placement:

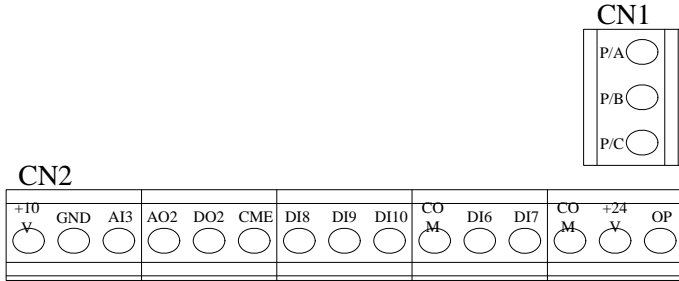

Fig3-6 Expansion card terminal placement

d) Function of expansion card:

Table 3-5 Function of expansion card

Sort	Terminal sign	Terminal name	Function
Power	+10V-GND	External connect+10V power	Supply +10V power , maximum output current:10mA Usually used as power for external potentiometer, resistance of the potentiometer: 1kΩ~5kΩ
	+24V-COM	External connect+24V power	Supply +24V power, usually used as power for digit input terminal and external sensor, maximum output current: 200mA
	OP	Exterior power supply input terminal	Factory default: connect +24V power When using exterior signal to drive DI1~DI5, OP should be connected to exterior power, and connection between OP and +24V power terminal should be cut.
Analogue input	AI3-GND	Reserved	Reserved
Function digit input terminal	DI6-COM	Digit input 6	1、 Optocoupler isolation , double polarity input compatible 2、 Input impedance: 3.3kΩ 3、 input voltage range: 9V~30V
	DI7-COM	Digit input 7	
	DI8-COM	Digit input 8	
	DI9-COM	Digit input 9	
	DI10-COM	Digit input 10	

Sort	Terminal sign	Terminal name	Function
Analogue output	AO2-GND	Reserved	Reserved
Digit output	DO2-CME	Digit output 2	Optocoupler isolation, double-polarity open collector output Output voltage: 0V~24V Output current: 0mA~50mA Note: Digit output CME and digit input COM are isolated inside, when using should make them jump out; when driving DO2 with exterior power, the outside jumper between CME and COM should be cut off.
Relay output	T/A-T/B	Normal close Terminal	Contactor driving capacity: AC: 250V、3A、 $\text{Cos}\phi=0.4$ DC: 30V、1A
	T/A-T/C	Normal open Terminal	
Communication	CNK2	Communication interface terminal	I/O digital terminal of RS-485 communication
Auxiliary interface	J1	Function expansion card	28-core terminal, special interface card
	J2	PG card interface	PG card special interface
	CN3	Outside lead keyboard interface	Outside-lead keyboard, parameter-copy-unit interface

e) Instructions of control terminal connecting:

A. Digital input terminal:

Shielded cable or twisted line are usually used in wiring (refer to 3.2.1 external electric components), and the wiring length must be as short as possible (less than 20 meters). If shielded line is used, please connect shielding layer with terminal PE at the side which is near the inverter.

When using active drive, filtering measure is essential to avoid interference of the power. It is recommended to use contactor control mode.

There are totally 10 digital input terminals in ME320L(N) inverter in two groups, 5 in control board, 5 in expansion board. This two groups can adopt external power supply, internal 24V power, high input level, low input level separately or at a same time, which can make the using convenient to a large extent. If there's any question, please contact the manufacturer.

B、Digital output terminal:

DO1、DO2 can adopt external or internal power, “NPN” or “PNP” can be set as output way.

When digital output terminals need to drive the relay, absorbing diode should be added at both sides of relay loop. Otherwise the DC 24V power or output circuit will be damaged.

Note: Absorbing diode must be set up correctly, which means its polarities have to be installed properly. Otherwise when the digital output terminal have output, it will burn out the DC 24V power and output circuit immediately.

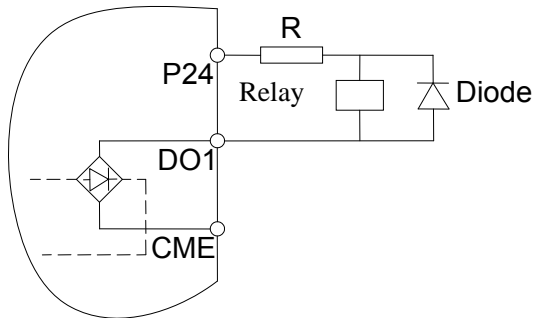

Fig 3-7 Digital output terminal connecting

C、Analogue input terminals:

The feeble analogue signal is apt to be influenced by external interference, so shielded cable is needed commonly, and the wiring length should be no more than 20 meters. Make sure the shield layer which is close to inverter is well grounded. Refer to Fig 3-8.

In the situation of some serious interference, filtering capacitor or ferrite magnetic core should be added at the side of analogue signal source. Refer to Fig 3-9.

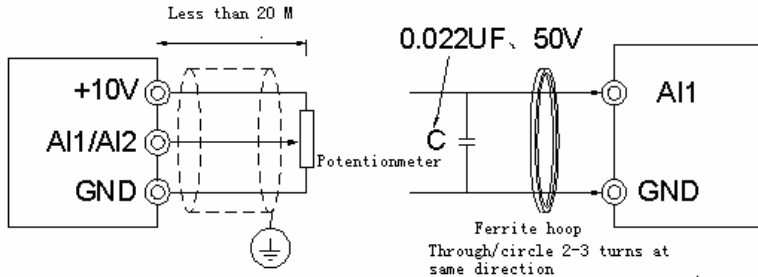

Fig 3-8 Analogue input terminal connection Fig 3-9 Analogue input signal disposal connection

3.2.4 Wiring and relative instructions of Elevator specialized rotary encoder interface board——PG card

1、MCTC-PG-A (Applicable to asynchronous motor, open-collector output, push-pull output, incremental encoder)

1) Technical target

Table 3-6 Technical target

	Function	Response speed	Output impedanc e	Output current	Frequency division
+15V, COM	Encoder power supply	---	About 300Ω	300mA	---
PGA, PGB	Encoder signal input	0~80kHz	---	---	---
OUT-A OUT-B	Frequency division signal output	0~80kHz	About 30Ω	100mA	1~62(even number)

2) PG card terminal and dail-up explanation

PG card has all together 9 user wiring terminals, refer to P3-10. +15PG、COM are encoder work power output terminals; PGA、PGB are encoder signal input terminals; OUT-A、OUT-B、COM are sub-frequency signal output terminals; PE is shielded wire terminal (PE is not grounded in PG card, when using, it must be grounded first.)

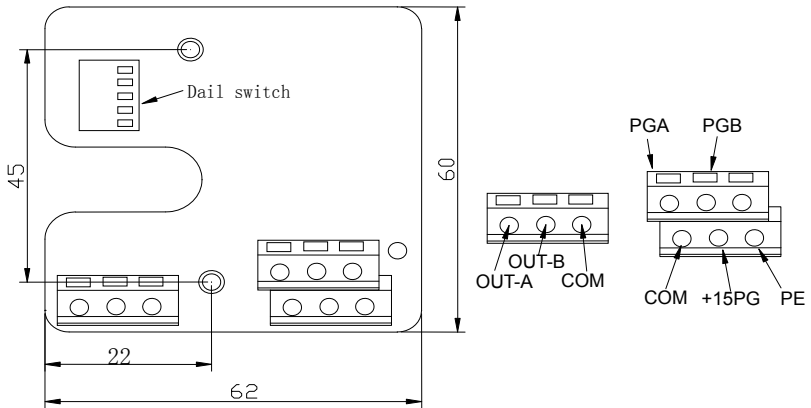

Fig 3-10 MCTC-PG-A Asynchronous motor PG card (push-pull input、open-collector input incremental encoder)

Frequency division factor is determined by dial switch on the PG card. Dial switch is 5-bit, and frequency division factor is twice the binary number showed by it. The mark "1" on the dial switch means low order of binary, and "5" means high order. When a dial-up is pushed to ON, it is effective, it's "1", otherwise it's "0".

The following is the look-up table of dial switch position and frequency division factor:

Table 3-7 look-up table of dial switch position and frequency division factor

Decimal	Binary number	Frequency division factor
0	00000	No frequency division signal output
1	00001	No frequency division signal output
2	00010	2*2 frequency division
...
l	...	l*2 frequency division
31	11111	31*2frequency division

3) PG card wiring

PG card with frequency division is the standard configuration of ME320L(N) inverter, pay attention to the following while wiring:

- A、 PG cable must be placed separate from that of the control circuit and power circuit, it's forbidden to place then parallelly together.
- B、 PG wiring must adopt shielded cable, the side of shielding layer near the inverter should be connected with terminal PE at the side which is near the inverter.
- C、 PG cable must be introduced into the metal pipe separately and make sure the shell of the

pipe is well grounded.

PG wiring is showed in P3-11:

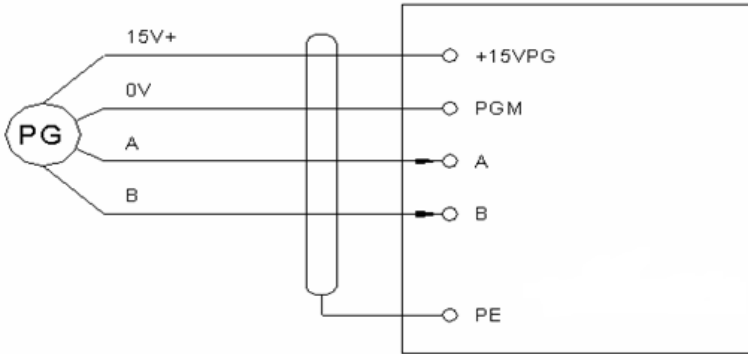

Fig3-11 PG wiring of MCTC-PG-A Asynchronous motor

2、MCTC-PG-B (Applicable to synchronous motor U、V、W encoders, Asynchronous motor long-term drive incremental encoder)

1) Technical targets:

	Function	Response speed	Output impedance	Output power	Frequency division
VCC, GND	Power supply of encoder	---	About 300Ω	300mA	---
A+, B+, A-, B-, U+, V+, W+, U-, V-, W-	Signal input of encoder	0kHz~80kHz	---	---	---
OUT-A, OUT-B, COM	Frequency division output	0kHz~80kHz	Around 30Ω	100mA	1

2) PG card terminals and dail-up explanation

PG card has all together 15 user wiring terminals, refer to P3-11. VCC、GND are encoder work power output terminals; A+, B+, A-, B-, U+, V+, W+, U-, V-, W- are encoder signal input terminals; OUT-A、OUT-B、COM are frequency division signal output terminals.

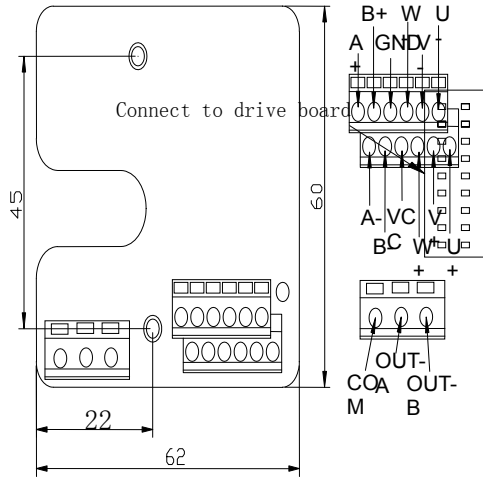

Fig 3-12 MCTC-PG-B synchronous motor U, V, W encoder or Asynchronous motor long-term drive incremental encoder PG card

3) MCTC-PG-B wiring instructions:

- A) PG cable must be placed separate from that of the control circuit and power circuit, it's forbidden to place them parallelly together.
- B) PG cable must be introduced into the metal pipe separately and make sure the shell of the pipe is well grounded.

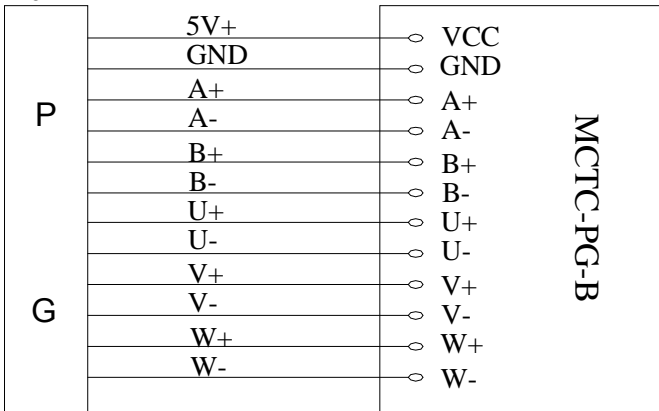

Fig 3-13 MCTC-PG-B PG wiring diagram

3.3 The solution for EMC problem

3.3.1 Influence of harmonics

1) The electric power has high-frequency harmonics in itself and will produce great influence to the rectify part, when the rectify bridge work for a long time the excessive heat may cause the work point drifting and damage the rectify bridge. If the power supply system is not very good, it is suggested to add filter or AC input reactor between power and the inverter, or install DC reactor to DC bus of inverter to settle the harmonics problem so as to protect the inverter.

2) The inverter output side will produce high-frequency harmonics, if adding capacitance or inrush suppresser which aims to improve power factor, it's possible to cause loop current ascillation, and lead to equipment damage. So capacitance or inrush suppressive equipment is forbidden to be added at output side.

3.3.2 Electromagnetic interference and its disposal

There are two kinds of electromagnetic interferences: The first one is the surrounding electromagnetic noise interference, which will bring the mis-action of inverter. Generally speaking, this kind of interfere will not cause great influence; because the inverter is designed to have comparatively strong anti-jamming capacity. The other one is the interference of the noise produced by the inverter to the surrounding equipment. Ways of settling the problems are as follows:

1) Disposal of the surrounding electromagnetic noise interference:

Generally, surrounding electromagnetic interference is caused by the large numbers of relays, contactors or electromagnetic brakes around the inverter. When facing with this kind of problem, use the following methods:

- a) Install inrush suppresser on the equipment which produce interfere.
- b) Install filter at the signal input terminal of the inverter.

2) Disposals of the interference of the noise produced by the inverter:

Premises of settling the problem:

- a) The inverter is well grounded, and the earthing resistance can not be more than 5Ω ;
- b) Drive power line of the inverter should not parallel with control line; if permitted, try to placa it vertically;
- c) At the place where interfere must be small enough, the power line between inverter and motor should adopt shielded cable and shielded layer should be well grounded.
- d) As to the lead wire of the equipment which suffers from the interference, it is suggested to use double-twist shielded line, and keep the shielded layer well grounded.

There are two kinds of noises: one is caused by the inverter itself, and the other is produced by the leads between inverter and motor. Both will bring electromagnetism and electrostatic induction to the surface of the surrounding equipments.

Common solutions are listed below:

- a) Apparatus, receivers or sensors which are used for measuring, usually have feeble signal around. If they are close to the inverter or in the same control panel with inverter, they are liable to get interference and come into malfunction. It is recommended to use following solutions: keep away from the interfere power; don't make the signal line parallel to the driving line, and parallel placement together is especially prohibitive; the signal line and driving line should adopt shielded cable; add linear filter or wireless noise filter in the input and output side of the inverter.
- b) When interfered equipment and inverter use the same power, the best bet is to add linear filter or wireless noise filter between the inverter and power if the interference isn't alleviative by the above solutions.
- c) Earth the peripheral equipments separately, which can eliminate the interference generated by grounding line's leakage current due to earthing together.

3.3.3 Electric leakage and its disposal

There are two forms of electric leakage when using controller: 1) leakage current to earth; 2) leakage among the lines.

1) Factors influencing leakage current to earth and solution.

There are distributed capacitance between lead and earth. The more the distributed capacitance is, the larger the leakage current is, so minishing the distance between the inverter and motor will reduce the distributed capacitance.

The higher the carrier frequency is, the larger the leakage current will be; we can reduce carrier frequency to reduce leakage current; but remember that it will increase the motor noise. Adding reactor is also an efficient way to reduce the leakage current.

2) Leakage current increases with the increase of loop current; therefore, large motor power will lead to corresponding large leakage current.

3) Factors influencing leakage current among the lines and solution.

There exists distributed capacitance among the inverter output lines; if the current passing circuit has high-frequency harmonics, resonance will occur and then lead to leakage current. Using thermal overload relay here may cause malfunction.

The resolution is to reduce carrier frequency or to add output reactor. When using the inverter it is not suggested to add thermal relay in the front of motor so as to use the electro-over-current protective function of the inverter.



Operation and Test-Run

Chapter 4 Operation and Test-run of the Inverter

This chapter is about the detailed information of keyboard oprating and function code setting of the ME320L(N) inverter display panel.

4.1 Terms of ME320L(N) Inverter

Main terms: operation mode, control mode, running mode and working state

4.1.1 Operation mode

Definition: Modes of receiving running command and speed instruction in any way. can select ME320L(N) inverter can choose only one of the operation modes.

Operation panel control: use the key RUN and STOP of the operation panel to control the inverter output.

Terminal command control: running command and running speed are controlled by input signal of multi-functional input terminal.

Communication command control: running command and running speed are given out through communication.

4.1.2 Control mode

ME320L(N) inverter has 3 kinds of control modes:

SVC

VC

V/F control

4.1.3 Running mode

Self-tuning running mode: ME320L(N) specialized inverter provides self-learning mode under loaded state and unloaded state. For details, please refer to parameter F1-11.

Common running mode: running under the control of operating panel or in the situation of set analogue.

Multi-stage-speed running mode: the running speed is controlled by the combination of multi-stage speeds.

ME320L(N) specialized inverter can select only one of the running modes.

4.1.4 Working state

ME320L(N) specialized inverter has four states in live state: stop state, program state, running state and fault-alarm state.

Stop state:

Re-electrify or stop after running command finished, the inverter is always at the waiting state until receiving another running command. At this moment, indicator light will go out with the contents in LED screen flashing; and the key “》” can be used to display different parameter circularly.

Program state:

Examine and set up the parameters through operating panel of inverter.

Running state:

The running indicator light is on when the controller is at the state of running, with the contents in LED screen un-flashing

Fault alarm state:

There comes fault of inverter and the fault code is displayed.

4.2 Introduction of operation and display panel

Operation keyboard with LED display is the standardized configuration of NICE2000 control system. Through this keyboard, user can modify the function parameter, monitor working state of controller, and control its running state (start or stop).

As to the appearance and function section, please refer to Fig 4-1:

4.2.1 Function instruction of indicator light:

RUN "ON" means the inverter is running.

LOCAL/REMOT Keyboard operation and long-distance operation indicator, "ON" means the inverter is under long-distance control.

FWD/REV Upward and downward running indicator, "ON" means the inverter is under up running condition, FWD command is effective; "OFF" means the inverter is under down running condition, REV command is effective. The indicator is invalid, when the elevator is stopped.

TUNE Tuning indicator, "ON" means the inverter is in tuning.



4.2.2 Digital display area:

Fig 4-1 operation panel

5-bit LED display, can display set frequency, output frequency and other monitor data and alarm codes.

4.2.3 Instructions of unit indicator:

Hz	Frequency unit	A	Current unit
V	Voltage unit	RPM	rotation speed unit
%	Percentage		

4.2.4 Instructions of buttons on the keyboard:

Table 4-1 Keyboard function

Key	Name	Function
PRG	Program key	Enter and exit the first-level menu and delete quick parameter

ENTER	Confirm key	Enter the menu level by level and set parameter conformation
^	Up key	Increase of data and function code
v	Down key	Decrease of data and function code
》	Shift key	Select the display parameters circularly at stop state and running state. Select the modification bit when modifying parameters.
RUN	Run key	Start up the machine in the terms of keyboard operation mode.
STOP/RESET	Stop/Reset key	Stop the machine when the inverter running. Reset the machine, when in the state of fault alarm.
QUICK	Quick key	Enter or exit the first-level of quick menu. Refer to QUICK operation instruction
MF.K	Multi-function selection key	Display and remove error information.

4.3 Function codes examination and operation instruction

4.3.1 Operation flow of 3-level menu:

ME320L(N) iinverter applies 3-level menu to set parameters on operation panel. It's convenient to query and modify function codes and parameters.

3-level menu include: function parameter group (first level)→function code (second level)→function code setting(third level). You can refer to operation flow chart Fig4-2.

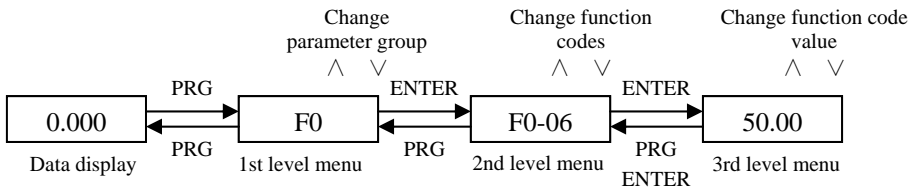

Fig 4-2 operation flow chart of 3level menu

Note: when in 3rd level menu operation, system can be backed to 2nd level menu by pressing “PRG” or “ENTER”. The difference between them: it goes back to 2nd menu with parameter saved when pressing “ENTER”, then jump to next function code automatically; while it back to the 2nd menu with the parameter unsaved and it will stay in the current function code.

Example: change F0-04 from 50.00Hz to 15.00Hz (boldfaced words means flash bit

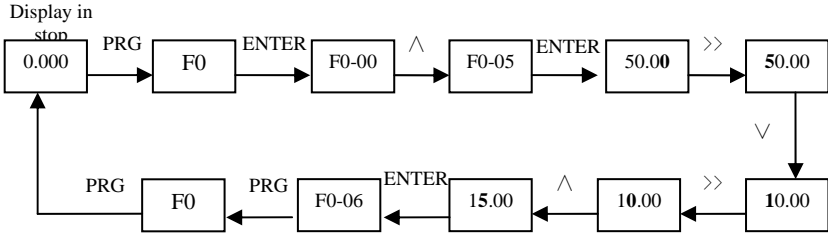

Fig 4-3 parameter editing operation process

In 3-level menu, if the parameter has no flash bit, it means the function code cannot be changed and the possible reasons are:

- 1) This function code is un-revisable, such as the actual examine parameter and running record parameter..
- 2) This function code cannot be changed in operating state and can only be changed when the inverter is stopped.

4.3.2 Switch state parameters display with shift key>>:

Example:

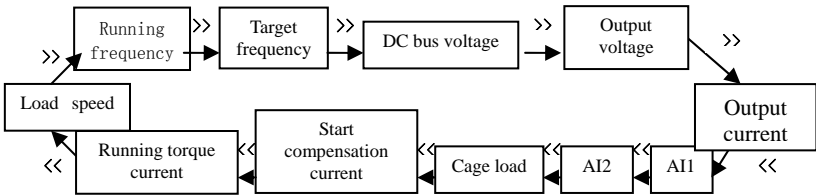

Fig4-4 Display switching of state parameters

LED can display various state parameters when ME320L(N) is in stop and running states. Whether to display detailed parameter content is dependent on the bit setting of F8-01(running parameter), F8-02(stop parameter). Through key >>, user can switch the display in sequence and display the stopping or running state parameters circularly.

In stop state, there are totally 8 parameters of ME320L(N) that can be displayed circularly by key >>. The parameters are: target linear speed, target frequency, DC bus voltage, AI1, AI2, cage load and others. Whether to display the state parameters is dependent on the bit setting of F8-02, through the key >>, user can switch the display in sequence and display the selected parameters.

In running state, there are 15 parameters: running frequency, load speed, target frequency,

DC bus voltage, output voltage, output current, AI1, AI2, cage load (%), start compensation current (%), running torque current (%), etc. Whether to display the state parameters is dependent on the bit setting of F8-01 through the key >>, user can switch the display in sequence and display the selected parameters.

4.3.3 Error information reading:

When error occurs, the error information codes will be displayed on the panel. It is convenient to find reason of error and get rid of the error as soon as possible.

The inverter can save the last 3 error code and record the last error frequency, current, bus voltage, digit input terminal state and digit output terminal state. The relative sketch map is listed below:

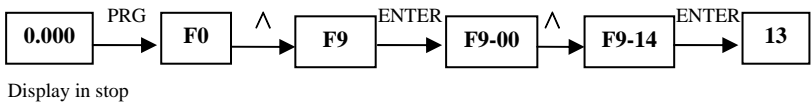

Fig4-5 Error information reading

4.3.4 Monitoring of digit input terminal state:

The state of digit input terminal should be monitored when running, details refer to F8-00 parameter instruction in Chapter 6.

4.4 Operation of shortcut menu

ME320L(N) inverter shortcut menu is for the user's convenient and quick checking and modification. The parameter display mode in the shortcut menu is "uF3-02", which means the function parameter F3-02. Changing the parameter in shortcut menu has the same effect with changing it in common state.

At most 16 function parameters can be saved in the shortcut menu. When 16 parameters have been stored, it will show "FULL" if more parameters are attempted to be added, "NULL" means no parameter has been stored in the menu. 16 common parameters have been stored in the initial menu:

F0-00: control mode	F3-00: start frequency
F0-01: command choose	F3-01: start frequency hold time
F0-02: speed choose	F4-13: multi-stage speed filtering time
F1-11: motor tuning choose	F8-00: terminal state display
F2-00: propotion1 factor	F8-03: load speed display
F2-01: integral 1 time	F9-16: last fault
F2-03: propotion 2 fector	FA-00: PG pulse number
F2-04: integral 2 time	FC-00: Command abnormal action selection

Users can edit it according to actual demand.

4.4.1 Add shortcut menu parameters:

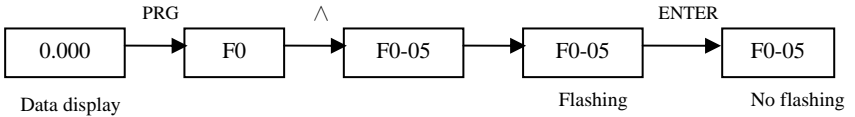

Fig4-6 setup of the shortcut menu

Note: When pressing “QUICK” in second level menu with the displayed contents flashing (which prompt the user to save the parameter into the quick menu or not), while pressing “ENTER”, when the contents stop flashing, the whole operation is finished. While pressing PRG, it will not save the parameter into the quick menu and when the displayed parameter stops flashing, the operation is cancelled.

4.4.2 Modify & retrieve the shortcut menu parameters

Example: retrieve parameters F0-00、F1-11、F4-13 and F8-03:

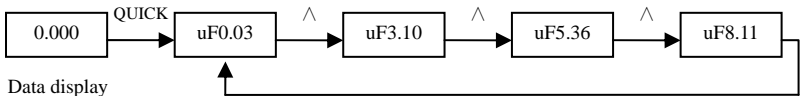

Fig4-7 retrieve shortcut menu

Modify: In stop or run display interface, press “QUICK” to enter quick menu, and press “UP/DOWN” to select different parameters, then press “ENTER” to enter the next level menu, here, the changing method is the same with that in the third level menu. Press “QUICK” to back to the last screen and the changed parameter will not be saved.

4.4.3 Delete shortcut menu parameters

If you want to delete F4-13 from the parameters F0-00、F1-11、F4-13 and F8-03 in the shortcut menu. Do according to the following steps:

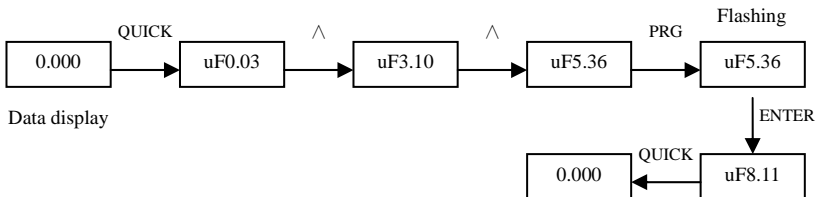

Fig4-8 Delete the shortcut menu

Note: Press “PRG” in the quick menu with displayed content flashing (which prompt the user to delete this parameter or not); then press “ENTER”, it will delete the parameter in the menu, when the content stop flashing, the whole operation finishes. While pressing “QUICK”, it will cancel the operation and the displayed parameter stops flashing. If the last parameter is deleted, “NULL” will be displayed, that means no parameter is stored in the menu.

4.5 Password setting

The inverter provides password protection to protect the parameters more effectively. The following figure shows how to change password into 12345.

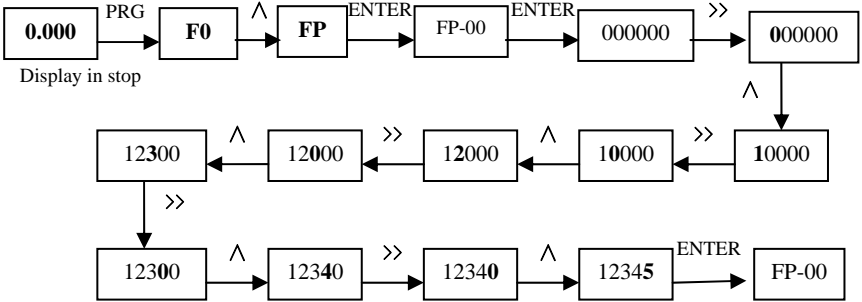

Fig4-9 Password setting

After setting the password (parameter FP.00 is not zero), if the user presses “PRG”, the inverter will enter password validation state first and display“----”. User can only enter the menu after inputting the correct password. For factory setting parameters editing, the user still need to input the factory password. (Warning: do not change the factory setting parameter; if the parameter values are wrong, the inverter will work abnormally, even be damaged.)

When the password protection is unlocked, user can change the password freely, and the last input will be the user password.

If the user wants to cancel the password protection function, enter after inputting the password and setting FP.00 as 0; if FP.00 is not zero, the parameter is password protected.

4.6 Motor parameter self-tuning

In order to choose the running mode of the vector control, before the running of the inverter nameplate parameters of the motor must be input correctly, then ME320L(N) inverter will select standard motor parameters according to the nameplate parameters. Parameters of the controlled motor must be accurate to achieve perfect control. Details refer to F1-11 explanation in Chapter 6 and adjustment explanation in Chapter 7.

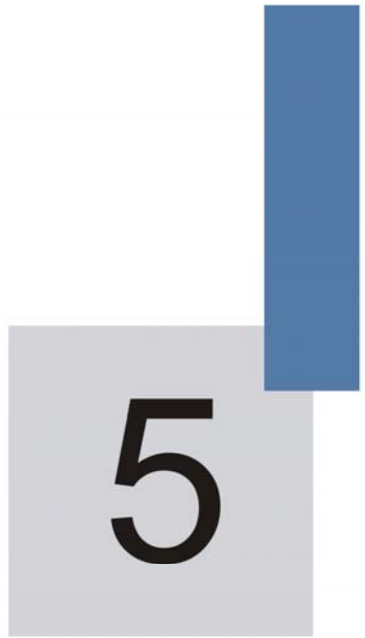

Function Parameter Table

Chapter 5 Function Parameter Table

This chapter lists all the functions of the inverter and relative information for interrogation.

5.1 Function Parameter Table

Function parameters of ME320L (N) inverter can be classified into 15 groups including F0~F9, FA~FF, FP. Each group includes certain function codes. Function codes apply 3-level menu with the format FX—XX, which means “NO XX” function code in group “X”. for example, “F9—08” means the 8th function code in Group F9.

In order to make function code setting convenient, the function group number corresponds to the first-level menu, the function code number corresponds to the second-level menu, and function code parameters correspond to the third-level menu.

The contents of function codes:

Column 1“Function code”: the serial number of function parameter groups and parameters;

Column 2“Name”: the complete name of the function parameters;

Column 3“Setting range”: the effective parameter setting range, displayed on LCD of operation panel;

Column 4“Minimum unit”: the minimum unit of the parameter setting;

Column 5“Factory setting”: the original default;

Column 6“Operation”: the modification attributes of the parameters (whether to enable the modification and the modification requirements).

Instructions are listed below:

☆: the parameter can be modified while the inverter is running or stopping;

★: the parameter can not be modified while the inverter is running;

●: the parameter cannot be modified for it is actually measured and recorded.

(The inverter has changing attribute self-inspection function for every parameter, which can help users avoid misoperation.)

“Factory Default” means the numeric value after the function code parameter is refreshed when recovering the default parameter, but the actually measured value or recorded value will not be refreshed.

The inverter provides password protection of function code to protect the parameters effectively (detailed in Chapter 4).

5.2 Function Groups

5.2.1 Classification of the functions

After pressing PRG and then UP/DOWN, all of the displays are the first-level menus, which are group of function. Details are as follows:

F0——Basic function

F8——keyboard and display

F1—motor parameter
 F2—vector control parameter
 F3—start/stop parameter
 F4—input terminal
 F5—output terminal
 F6—speed parameter
 F7—curve parameter
 F9—fault and protection
 FA—PG parameter
 FB—communication parameter
 FC—special enhancement function
 FF—factory parameter
 FP—user password

5.2.2 Detailed Function Parameter Table:

Function code	Name	Setting range	Minimum unit	Factory setting	Operation
F0—Basic function					
F0-00	Control mode	0: (SVC) 1: (VC) 2: V/F control	1	1	★
F0-01	Command choose	0: command channel of operation panel (LED off); 1: command channel of terminal running (LED on); 2: communication control (special card)	1	1	★
F0-02	Speed choose	0: digit setting 1: multi-stage speed 1 2: AI1 3: AI2 4: communication setting (special card)	1	1	★
F0-03	Digit setting frequency	0.00~maximum frequency	0.01Hz	00.00Hz	☆
F0-04	Running direction	0: same direction 1: opposite direction	1	0	★
F0-05	Maximum frequency	10.00Hz~90.00Hz	0.01Hz	50.00Hz	★
F0-06	Carrier frequency	0.5kHz~16.0kHz	0.1kHz	Decided by model	☆

Function code	Name	Setting range	Minimum unit	Factory setting	Operation
F0-07	Carrier frequency adjustment choosing	0: Fixed PWM, carrier frequency temperature adjustment ineffective 1: Random PWM, carrier frequency temperature adjustment ineffective 2: Fixed PWM, carrier temperature adjustment effective 3 : Random PWM , carrier temperature adjustment effective	1	2	☆
F1—Motor parameters					
F1-00	Encoder choosing	0: SIN/COS 1: UVW	1	1	★
F1-01	Rated power	0.4kW~1000.0kW	0.1kW	Decided by model	★
F1-02	Rated voltage	0~440V	1V	380	★
F1-03	Rated current	0.00~655.35A	0.01A	Decided by model	★
F1-04	Rated frequency	0~maximun frequency	0.01Hz	50.00Hz	★
F1-05	Rated rotation speed	0~30000rpm	1rpm	1460rpm	★
F1-06	Stator resistance	0.001Ω~65.535Ω	0.001Ω	Decided by model	☆
F1-07	Rotator resistance	0.001Ω~65.535Ω	0.001Ω	Decided by model	☆
F1-08	Leakage inductance	0.01mH~655.35mH	0.01mH	Decided by model	☆
F1-09	Mutual inductance	0.1mH~6553.5mH	0.1mH	Decided by model	☆
F1-10	No-load current	0.01A~650.00A	0.01A	Decided by model	☆
F1-11	Motor tuning selection	0: No tuning 1: Static tuning 2: Dynamic tuning	1	0	★
F2—Vector control parameter					
F2-00	Speed loop propotion factor 1	0~100	1	35	☆

Function code	Name	Setting range	Minimum unit	Factory setting	Operation
F2-01	Speed loop integration time 1	0.01s~10.00s	0.01s	0.60s	☆
F2-02	Switching frequency 1	0.00~F2-05	0.01Hz	2.00Hz	☆
F2-03	Speed loop proportion factor 2	0~100	1	30	☆
F2-04	Speed loop integration time 2	0.01s~10.00s	0.01s	0.80	☆
F2-05	Switching frequency 2	F2-02~Maximun frequency	0.01Hz	5.00Hz	☆
F2-06	Proportional gain of current loop	10~300	1	60	☆
F2-07	Integral gain of current loop	10~300	1	30	☆
F2-08	Upper limit of torque	0.0%~200.0%	0.1%	150.0%	☆
F3—Start/Stop parameters					
F3-00	Start frequency	0.00Hz~10.00Hz	0.01Hz	0.00Hz	☆
F3-01	Torque output delay	0.00s~10.00s	0.01s	0.20s	★
F3-02	Brake open delay	0.00s~10.00s	0.01s	0.10s	★
F3-03	Zero-speed delay	0.00s~10.00s	0.01s	0.30s	★
F3-04	Start time	0.00s~10.00s	0.1s	0.0s	★
F3-05	Startup frequency hold time	0.00s~10.00s	0.1s	0.0s	★
F3-06	Brake release delay	0.00s~10.00s	0.01s	0.20s	★
F3-07	Stalling zero-speed delay	0.00s~10.00s	0.01s	0.30s	★
F3-08	Running contactor release delay	0.00s~10.00s	0.01s	0.00s	★
F3-09	Start pre-torque setting selection	0:No pre-torque 1:DI setting 2:A11 setting 3:A12 setting 4:use pre-torque initial bias 5:No weighing compensation	1	0	★
F3-10	Pre-torque bias	0.0%~100.0%	0.1%	48.0	☆

Function code	Name	Setting range	Minimum unit	Factory setting	Operation
F3-11	Pre-torque gain	0.00~1.50	0.01	0.60	★
F3-12	Pre-torque initial bias	-100.0%~100.0%	0.1%	10.0%	★
F3-13	DI weighing signal1	0%~100.0%	0.1%	10.0%	★
F3-14	DI weighing signal 2	0%~100.0%	0.1%	30.0%	★
F3-15	DI weighing signal 3	0%~100.0%	0.1%	70.0%	★
F3-16	DI weighing signal 4	0%~100.0%	0.1%	90.0%	★
F3-17	Weighing analogue input Filtering time	0.00s~1.00s	0.01s	0.10s	☆
F3-18	Weighing analogue no-load Corresponding input	0.00V~10.00V	0.01V	0.00V	☆
F3-19	Weighing analogue loaded Corresponding input	0.00V~10.00V	0.01V	10.00V	☆
F3-20	Analog weighing self-learning	0~100	1	0	☆
F3-21	Analog weighing self-learning selection	0: No 1: Permitted	1	0	☆
F3-22	Reverse pre-torque direction or not	0: Not change 1: Reverse direction	1	0	☆
F4—Input terminal					
F4-00	DI filtering time	0.000s~0.200s	0.001	0.020s	☆
F4-01	DI1 terminal function choosing	0: No function 1: Forward command (FWD、	1	1	★
F4-02	DI2 terminal function choosing	upward) 2: Reverse command	1	2	★
F4-03	DI3 terminal function choosing	(REV、downward) 3: Multi-stage terminal 1	1	3	★
F4-04	DI4 terminal function choosing	4: Multi-stage terminal 2 5: Multi-stage terminal 3	1	4	★
F4-05	DI5 terminal function choosing	6: Fault reset 7: Enable control	1	5	★

Function code	Name	Setting range	Minimum unit	Factory setting	Operation
F4-06	DI6 terminal function choosing	8: Inspection and mending input 9: Emergency input	1	6	★
F4-07	DI7 terminal function choosing	10: Running contactor feedback	1	7	★
F4-08	DI8 terminal function choosing	11: Brake feedback 12: Weighing terminal 1	1	0	★
F4-09	DI9 terminal function choosing	13: Weighing terminal 2 14: Weighing terminal 3	1	0	★
F4-10	DI10 terminal function choosing	15: Weighing terminal 4 16: External fault	1	0	★
F4-11	Reserved	17: Motor over-heat 18: Upward speed defining 19: Downward speed defining Terminal input range is 0~119, the 1 on the hundred bit means th signal is normal closed; the last 2 bits mean terminal input function selection, but when it's bigger than 19,it's ineffective. For example : 106 , means the terminal if Fault reset function, signal is normal closed.	1	0	★
F4-12	Reserved	0.000s~0.200s	0.001	0.005	★
F4-13	Multi-stage speed combination filtering time	0.000s~0.200s	0.001	0.020s	☆
F5——Output terminals					
F5-00	FMR output selection	0: No output 1: In running	1	15	★
F5-01	DO1 output selection	2 : zero-speed running (under zero-speed, running condition)	1	3	☆
F5-02	DO2 output selection	3: zero-speed signal (ouput exists in stop)	1	0	☆
F5-03	RELAY1 output selection	4: fault signal 5 : Running contactor ooutput	1	4	☆

Function code	Name	Setting range	Minimum unit	Factory setting	Operation
F5-04	RELAY2 output selection	control 6: Brake output control	1	0	☆
F5-05	Reserved	7: Previous dooropen signal 8: Bus undervoltage 9: FDT 1 output 10: FDT 2 output 11: Frequency arrival 12: Overspeed output 13: Overload alarm 14: Running time arrival 15: Running preparation done 16: Contact conglutination output control	1	0	☆
F5-06	Zero-speed output relay time	0.000s~3.000s	1	0.000s	☆
F5-07	AO output selection	0: Running frequency 1: Setting frequency 2: Output current 3: Output torque 4: Output voltage 5: AI1 6: AI2	1	0	☆
F5-08	AO bias	-100.0%~100.0%	0.1%	0.0%	☆
F5-09	AO gain	-10.00~10.00	0.01	1.00	☆
F6—Speed parameters					
F6-00	Multi-stage speed 0	0~maximum frequency	0.01Hz	0.00Hz	★
F6-01	Multi-stage speed 1	0~maximum frequency	0.01Hz	0.00Hz	★
F6-02	Multi-stage speed 2	0~maximum frequency	0.01Hz	0.00Hz	★
F6-03	Multi-stage speed 3	0~maximum frequency	0.01Hz	0.00Hz	★
F6-04	Multi-stage speed 4	0~maximum frequency	0.01Hz	0.00Hz	★
F6-05	Multi-stage speed 5	0~maximum frequency	0.01Hz	0.00Hz	★
F6-06	Multi-stage speed 6	0~maximum frequency	0.01Hz	0.00Hz	★
F6-07	Multi-stage speed 7	0~maximum frequency	0.01Hz	0.00Hz	★

Function code	Name	Setting range	Minimum unit	Factory setting	Operation
F6-08	Multi-stage speed 0 acceleration and deceleration time selection	1~4	1	1	★
F6-09	Multi-stage speed 1 acceleration and deceleration time selection	1~4	1	1	★
F6-10	Multi-stage speed 2 acceleration and deceleration time selection	1~4	1	1	★
F6-11	Multi-stage speed 3 acceleration and deceleration time selection	1~4	1	1	★
F6-12	Multi-stage speed 4 acceleration and deceleration time selection	1~4	1	1	★
F6-13	Multi-stage speed 5 acceleration and deceleration time selection	1~4	1	1	★
F6-14	Multi-stage speed 6 acceleration and deceleration time selection	1~4	1	1	★
F6-15	Multi-stage speed 7 acceleration and deceleration time selection	1~4	1	1	★
F6-16	Inspection time selection	0~7	1	0	★
F6-17	Power-off emergency help selection	0: No motor running 1: UPS powering running 2: 48V battery power-supply	1	0	★

Function code	Name	Setting range	Minimum unit	Factory setting	Operation
F6-18	Analog minimum input	0.00V~10.00V	0.01V	0.00V	☆
F6-19	Analog minimum input corresponding setting	0.0%~100.0%	0.1%	0.0%	☆
F6-20	Analog maximum input	0.00V~10.00V	0.01V	10.00V	☆
F6-21	Analog maximum input corresponding setting	0.0%~100.0%	0.1%	100.0%	☆
F6-22	Analog input filtering time	0.00s~10.00s	0.01s	0.10s	☆
F6-23	Inverter function selection	0~65535 BIT0: 1: Reduce current to 0 within (F6-26+250) ms during normal stalling, 0: Original stop mode;	1	0	☆
F6-24	Voltage setting when motor is overheated	0.00V~10.00V	0.01V	0.0V	☆
F6-26	Current withdraw time after stop	0~9999ms	0ms	100ms	☆
F6-27	Zero-speed signal output delay	0~9999ms	1	0	☆
F7—Curve parameters					
F7-00	Acceleration time 1	1.0s~100.0s	0.1s	4.0s	☆
F7-01	Deceleration time 1	1.0s~100.0s	0.1s	4.0s	☆
F7-02	S curve 1 starting stage time	10.0%~40.0%	0.1%	40.0%	★
F7-03	S curve 1 ending stage time	10.0%~40.0%	0.1%	40.0%	★
F7-04	Acceleration time 2	1.0s~100.0s	0.1s	4.0s	☆
F7-05	Deceleration time 2	1.0s~100.0s	0.1s	4.0s	☆
F7-06	S curve 2 starting stage time	10.0%~40.0%	0.1%	40.0%	★

Function code	Name	Setting range	Minimum unit	Factory setting	Operation
F7-07	S curve 2 ending stage time	10.0%~40.0%	0.1%	40.0%	★
F7-08	Acceleration time 3	1.0s~100.0s	0.1s	4.0s	☆
F7-09	Deceleration time 3	1.0s~100.0s	0.1s	20.0s	☆
F7-10	S curve 3 starting stage time	10.0%~50.0%	0.1%	40.0%	★
F7-11	S curve 3 ending stage time	10.0%~50.0%	0.1%	40.0%	★
F7-12	Acceleration time 4	0.5s~100.0s	0.1s	1.0s	☆
F7-13	Deceleration time 4	0.5s~100.0s	0.1s	1.0s	☆
F7-14	S curve 4 starting stage time	10.0%~50.0%	0.1%	40.0%	★
F7-15	S curve 4 ending stage time	10.0%~50.0%	0.1%	40.0%	★
F8—Keyboard and display					
F8-00	I/O terminal state indicator	-	-	-	●
F8-01	Parameters displayed by LED during its running	0~32767 Bit0: Load speed Bit1: Running frequency Bit2: Target frequency Bit3: DC bus voltage Bit4: Output voltage Bit5: Output current Bit6: AI1 Bit7: AI2 Bit8: Cage load (%) Bit9: Start compensation current (%) Bit10: Running torque current (%) Bit11: Input state Bit12: Output state	1	32767	☆

Function code	Name	Setting range	Minimum unit	Factory setting	Operation
F8-02	Parameters displayed by LED when It's stopped	1~255 Bit0: Target load speed Bit1: Target frequency Bit2: DC bus voltage Bit3: AI1 Bit4: AI2 Bit5: Cage load (%) Bit6: Input state Bit7: Output state	1	255	☆
F8-03	Load speed display factor	0.01~100.00	0.01	0.32	☆
F8-04	Radiator temperature	0.0℃~100℃	1℃	-	●
F8-05	Software version number 1	0~99.99	1	-	●
F8-06	Software version number 2	0~99.99	1	-	●
F8-07	Setting running time	0h~65535h 0: This function ineffective	1h	0h	☆
F8-08	Accumulated working time	0h~65535h	1h	0h	●
F8-09	Accumulated seconds	0s~3600s	1	0	●
F8-10	High bit of running times	0~9999 Note : 1 means actual running times are 10000	1	0	●
F8-11	Low bit of running times	0~9999	1	0	●
F8-12	Grounding short protection testing during power-on	0: Ineffective 1: Effective	1	0	☆
F9——Fault and protection					
F9-00	Motor over-load protection selection	0: Forbidden 1: Permitted	1	1	☆
F9-01	Motor over-load protection gain	0.20~10.00	0.01	1.00	☆

Function code	Name	Setting range	Minimum unit	Factory setting	Operation
F9-02	Motor over-load alarm factor	50%~100%	1%	80%	☆
F9-03	Over-voltage stall gain	0 (No Over-voltage stall) ~100	1	0	☆
F9-04	Over-voltage stall protection voltage	120%~150%	1%	130%	☆
F9-05	Over-current stall gain	0~100	1	20	☆
F9-06	Over-current stall protection current	100%~200%	1%	150%	☆
F9-07	Instantaneous stop non-stop function	0: Forbidden 1: Permitted	1	0	☆
F9-08	Instantaneous stop non-stop frequency reducing rate	0.00Hz/s ~ maximum frequency Hz/s	0.01Hz/s	10.00Hz/s	☆
F9-09	Fault automatic reset times	0~3	1	1	☆
F9-10	Faulted relay actuation selection during fault automatic reset	0: Non-actuation 1: Actuation	1	0	☆
F9-11	Interval of fault automatic reset	0.1s~100.0s	0.1s	1.0s	☆
F9-12	Input phase-failure protection selection	0: Forbidden 1: Permitted	1	1	☆
F9-13	Output phase-failure protection selection	0: Forbidden 1: Permitted	1	1	☆
F9-14	First error type	0: No error 1: Inverse unit protection (ERR01) 2 : Accelerated over-current (ERR02) 3 : Decelerated over-current (ERR03) 4: Constant over-current (ERR04) 5 : Accelerated over-voltage	-	-	●

Function code	Name	Setting range	Minimum unit	Factory setting	Operation
		(ERR05) 6 : Decelerated over-voltage (ERR06) 7: Constant over-voltage (ERR07) 8: Controller power fault (ERR08) 9: Undervoltage fault (ERR09) 10: Inverter overload (ERR10) 11: Motor overload (ERR11) 12 : Phase-failure in input side (ERR12) 13: Phase-failure in output side (ERR13) 14: Radiator overheated (ERR14) 15: External fault (ERR15) 16: Communication fault (ERR16) 17: Reserved 18 : Current detection fault (ERR18) 19: Motor tuning fault (ERR19) 20 : Pulse wheel encoder fault (ERR20) 21: Rotary encoder fault (ERR21) 22: Contact conglutination (ERR22) 23: Motor grounding short (ERR23) 25: Data storage fault (ERR25) 32: Battery overspeed (ERR32) 33: Overspeed fault (ERR33) 34: Large speed deviation (ERR34) 36: Contactor fault (ERR36) 37: Brake fault (ERR37) 38 : Contactor conglutination (ERR38) 39: Motor overheated (ERR39) 40: Not conform to elevator running conditions (ERR40)			
F9-15	The second error type		-	-	•

Function code	Name	Setting range	Minimum unit	Factory setting	Operation
F9-16	The last error type		-	-	●
F9-17	Frequency during error	-	-	-	●
F9-18	Current during error	-	-	-	●
F9-19	Bus voltage during error	-	-	-	●
F9-20	Input terminal during error	-	-	-	●
F9-21	Output terminal during error	-	-	-	●
FA——PG Parameters					
FA-00	PG pulse times	100~10000	1	1024	★
FA-01	PG line braking testing time	0s ~ 10.0s (<2s , testing function ineffective)	0.1s	3.0s	★
FA-02	Reserved	-	-	-	-
FA-03	PG magnetic pole angle	0.0~359.9	0.1	0.0	★
FA-04	PG current magnetic pole angle	0.0~359.9	0.1	0.0	●
FA-05	UVW wiring mode	0~3	1	0	★
FB——Communication parameters					
FB-00	Baud rate	0: 300BPS 1: 600BPS 2: 1200BPS 3: 2400BPS 4: 4800BPS 5: 9600BPS 6: 19200BPS 7: 38400BPS	1	5	☆
FB-01	Data format	0: No checkout 1: Even checkout 2: Odd checkout	1	0	☆
FB-02	Motor address	1 ~ 126; 127 is broadcasting address	1	1	☆
FB-03	Response delay	0ms~20ms	1	2	☆
FB-04	Communication overtime	0.0 (ineffective), 0.1s~100.0s	0.1s	0.0	☆
FC—— Special Enhancement function					
FC-00	Strange command actuation selection	0: Decelerate running 1: Block output at once	1	1	★
FC-01	Strange deceleration time selection	0.1s~300.0s	0.1s	3.0s	★
FC-02	Upward frequency detection level	0.00~maximun frequency	0.01Hz	45.00Hz	★
FC-03	Downward frequency detection level	0.00~maximun frequency	0.01Hz	45.00Hz	★

Function code	Name	Setting range	Minimum unit	Factory setting	Operation
FC-04	Early dooropen judgment	0.00~maximun frequency	0.01Hz	5.00Hz	★
FC-05	Frequency detection level 1	0.00~maximun frequency	0.01Hz	50.00Hz	☆
FC-06	Frequency detection level 2	0.00~maximun frequency	0.01Hz	50.00Hz	☆
FC-07	Frequency detection lag	0.0% ~ 100.0% (frequency detection level)	0.1%	5.0%	☆
FC-08	Frequency arrival detection width	0.0% ~ 100.0% (maximum frequency)	0.1%	0.0%	☆
FC-09	Overspeed judgment level	80%~120%	1%	115%	☆
FC-10	Overspeed detection delay time	0.0s~5.0s	0.1s	1s	☆
FC-11	Overspeed actuation selection	0: Strange decleration stop 1: alarm at once, block output 2: Continue running	1	1	☆
FC-12	Speed deviation judgment level	0%~50%	1%	30%	☆
FC-13	Speed deviation detection delay time	0.0s~5.0s	1s	1s	☆
FC-14	Large speed deviation actuation selection	0: Strange decleration stop 1: alarm at once, block output 2: Continue running	1	2	☆
FC-15	Braking and running order selection	0: runing first, then braking 1: braking first, then running	1	0	☆
FD——Special function					
FD-00	Torque hoisting	0.0: (Automatic) 0.1%~30.0%	0.1%	1.0%	★
FD-01	Torque hoisting frequency	0~maximun frequency	0.01Hz	50.00Hz	★
FD-02	Slip compensation	0.0%~200.0%	0.1%	100.0%	★
FD-03	Oscillation suppression gains	0~100	1	20	★
FD-05	Zero-servo current factor	1.0%~50.0%	0.1%	15.0%	☆
FD-06	Zero-servo speed loop KP	0.05~1.00	0.01	0.50	☆
FD-07	Zero-servo speed loop TI	0.05~2.00	0.01	0.60	☆
FP——User password					
FP-00	User password	0~65535 0: No password	1	0	☆
FP-01	Parameter updating	0: No 1: recover factory parameter 2: Clear memorizes information	1	0	★
FP-02	User setting testing	0: Ineffective 1: Effective	1	0	★

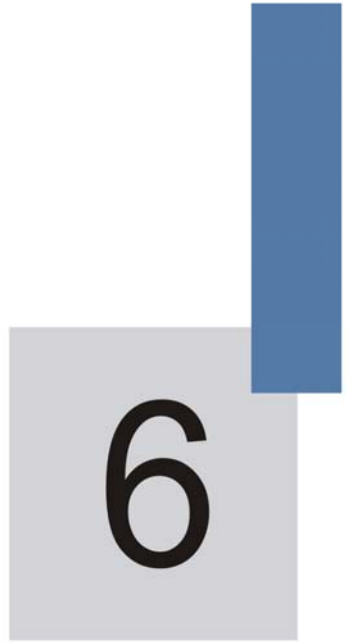

Function parameter Specification

Chapter 6 Function Parameter Specification

6.1 F0 Basic Parameters

F0-00	Control mode		Factory default	1
	Setting range	0	SVC	
		1	VC	
		2	V/F control	

ME320L(N) inverter provides high-performance vector control technique, which can be chosen through F0-00.

0: SVC

It refers to open-loop vector. It's mainly used in adjusting stage running and fault judging running in maintenance. Note that it's only applicable to Asynchronous motor. Synchronous motor can only adopt close-loop control.

1: VC

It refers to close-loop vector, applicable to high-accuracy speed control. ME320L(N) inverter should work in this condition during normal application of elevator.

2: Applicable to special occasion. It needs no rotary encoder, but its control effect is not as good as vector control.

Instruction: When choosing control mode must identify the motor parameters first. Only when accurate motor parameters are got, can the advantages of vector control be made use of. Better performance can be achieved through adjusting speed parameters (Group F2).

F0-01	Command selection		Factory default	1
	Setting range	0	Operation panel command	
		1	Terminal command	
		2	Communication control command	

Choose inverter control command channel.

Inverter control command includes: startup, stop, ect.

0: Keyboard control ("LOCAL/REMOT" off) ;

Command control can be conducted through RUN、STOP/RES on the keyboard. Running direction can be changed by setting F0-04.

1: Terminal command ("LOCAL/REMOT" on) ;

Command control are conducted by FWD, REV of multi-functional terminal.

2: Communication control ("LOCAL/REMOT" flashing)

Command is given out by upper computer or special communication card. When this item is chosen, special communication card (option) should be selected.

【Note】 under distance control (F0-01=1), F0-00 is confined as 1, it cannot be changed.

F0-02	Speed selection		Factory default	1	
	Setting range	0	Digit setting		
		1	Multi-stage speed		
		2	AI1		
		3	AI2		
4	Communication setting (Adopt special card)				

Choose inverter speed input channel. Altogether 4 channels:

0: Digit setting

ME320L(N) speed adopt internal digit setting value, its initial value is the value of "Digit setting frequency" in F0-03.

1: Multi-stage speed

This parameter is chosen when inverter running mode is multi-stage speed running mode.

The relationship between given signal and given frequency is defined by "Input parameter" in F4group and "speed parameter" in F6 group.

2: AI1 3: AI2

It means frequency is determined by analog input terminal. ME320L(N) inverter standard unit provides 2 analog input terminal. In them AI1 is terminal for voltage input (0V~10V), AI2 can be both voltage (0V~10V) input terminal and current (4mA~20mA) input terminal, this is chosen by J3 jumper on the control panel.

4: Communication setting (Adopt special card)

ME320L(N) receives given speed by communication with special optional expansion card.

F0-03	Digit setting frequency		Factory default	0.00Hz
	Setting range	0.00Hz~ maximum frequency		

ME320L(N) speed adopts the target running frequency after digit setting.

F0-04	Running direction		Factory default	0
	Setting range	0	Same	
1		Reverse		

Rotation direction of the traction machine can be changed by changing the function code without changing its wiring.

Instruction: when the parameter is initialized, running direction will change to the initial one.

So please be careful about using this function.

F0-05	Maximum frequency		Factory default	50.00Hz
	Setting range	10.00Hz~90.00Hz		

It's used to set the maximum frequency of the inverter. When frequency higher than work frequency is used because of special need, please think about the load of the mechanical

part.

F0-06	Carrier frequency		Factory default	Decided by model
	Setting range	0.5kHz~16.0kHz		

This function is to adjust carrier frequency, which can reduce the noise of motor, get rid of the point of resonance, decrease leakage current to ground and the interference caused by the inverter.

When the carrier frequency is low, higher harmonics in output current will increase, consumption as well as elevated temperature of motor will increase, too.

When the carrier frequency is high, consumption and elevated temperature of motor will reduce, but that of the inverter will increase, and at the same time the interference will increase.

The influence of adjusting carrier frequency on the following performances:

Carrier frequency	Low	~	High
Motor noise	Big	~	Small
Output current wave form	Bad	~	Good
Elevated temperature of motor	More	~	Less
Elevated temperature of inverter	Less	~	More
Leakage current	Small	~	Big
Interference caused	Small	~	Big

F0-07	Carrier frequency adjustment selection		Factory default	2
	Setting range	0	Fixed PWM, temperature adjustment is ineffective	
		1	Random PWM, temperature adjustment is ineffective	
		2	Fixed PWM, temperature adjustment is effective	
		3	Random PWM, temperature adjustment is effective	

Provides carrier frequency adjustment for fixed and random PWM. The noise frequency domain of random PWM motor is wide, while the noise frequency of fixed PWM motor is fixed.

That temperature adjustment of carrier frequency is effective means the inverter can adjust carrier frequency automatically according to its own temperature. This function can reduce the inverter over-heat alarming.

6.2 F1 Group Motor parameters

F1-00	Encoder type selection		Factory default	1
	Setting range	0	SIN/COS	
		1	UVW	
F1-01	Rated power		Factory default	Decided by model
	Setting range	0.4kW~1000.0kW		

F1-02	Rated voltage		Factory default	380V
	Setting range	0V~440V		
F1-03	Rated current		Factory default	Decided by model
	Setting range	0.00A~655.00A		
F1-04	Rated frequency		Factory default	Decided by model
	Setting range	0.00Hz~3000.0Hz		
F1-05	Rated rotation speed		Factory default	1460rpm
	Setting range	0rpm~30000rpm		

F1-00=0 must be applied when SIN/COS rotary encoder is chosen; and the pulse times of rotary encoder should be changed into 2048.

When motor self-tuning is normally finished, the setting value of F1-00~F1-05 will update automatically.

Please set according to the parameters on the motor nameplate.

Note: The high performance of vector control is ensured by accurate motor parameters. ME320L(N) inverter has parameter self-tuning function. But accurate parameter self-tuning is dependent on correct setting of the rated parameters of the motor.

In order to guarantee the control performance, please configure standard applicable motor for the inverter. If the motor power is strangely different from the standard, control performance of the inverter will go down obviously.

F1-06	Stator resistance		Factory default	Decided by model
	Setting range	0.001Ω~65.535Ω		
F1-07	Rotator resistance		Factory default	Decided by model
	Setting range	0.001Ω~65.535Ω		
F1-08	Leakage inductance		Factory default	Decided by model
	Setting range	0.01mH~655.35mH		
F1-09	Mutual inductance		Factory default	Decided by model
	Setting range	0.1mH~6553.5mH		
F1-10	No-load current		Factory default	Decided by model
	Setting range	0.01A~650.00A		

When motor self-tuning is normally finished, the setting value of F1-06~F1-10 will update automatically.

If not permitted in the scene, the motor can be tuned by inputting parameters manually taking known parameters of similar motor as a reference.

BIT1 and BIT2 of F1-10 is the switch of whether the SIN/COS encoder will alarm when it's interfered. (BIT0 and other BITpost are not used)

- 1、BIT1 controls if Err17 will be given out, BIT1=1 means Err17 can be given out;
- 2、BIT2 controls if Err16 will be given out, BIT2=1 means Err16 can be given out.

Note: Every change to the motor rated power F1-01, the system will recover parameter

F1-06~F1-10 to default.

F1-11	Tuning selection		Factory default	0	
	Setting range	0	No operation		
		1	Static tuning		
		2	Complete tuning		

Tip: Correct rated motor parameters (F1-01~F1-05) must be set before tuning.

0: No operation

1: Static tuning

Applicable to asynchronous motor, when it's loaded and rotary tuning cannot be realized.

Action specification: Set the function code as 1, and press RUN, then the inverter will conduct static tuning.

2: Complete tuning

Action specification: Set the function code as 2, and press RUN, then the inverter will conduct rotary tuning.

In order to ensure the dynamic control performance of the inverter, please choose rotary tuning. When doing rotary tuning, the motor must be non-loaded.

When rotary tuning is chosen, the inverter conducts static tuning first. When it's over, asynchronous motor will accelerate to 80% of the motor rated frequency during the acceleration time according to F7-00, and keep it for some time, then decelerate to 0 during the deceleration time according to F7-01.。

Instructions of tuning:

When F1-11 is set as 1 or 2 and the key ENTER is pressed, "TUNE" will be displayed and falshig, press "RUN", parameter tuning will start, and "TUNE" stops flashing. When tuning is over, display will be back to stop interface. During tuning process if you press "STOP", tuning will be stopped.

When tuning is over, F1-11 will back to 0.

Note: Permanent-magnet synchronous motor must adopt complete tuning, which not only distinguishes relative parameters of motor, but also 还对安装的编码器进行原点识别。 Permanent-magnet synchronous motor is forbidden to run before complete tuning.

▲Asynchronous motor parameter automatic tuning steps are as follows:

First, set F0-01 to 0: choose operation panel command channel control as the control mode;

According to the actual type of the motor set F1-00 to 0: Asynchronous motor. Then set

F1-01、F1-02、F1-03、F1-04、F1-05 according to motor nameplate;

If the motor can be non-loaded, set F1-11 to 2 (complete tuning), then press RUN, the motor will run automatically. When the inverter has calculated the following parameters: F1-06 (stator resistance)、F1-07 (rotator resistance)、F1-08 (leakage inductance)、F1-09 (mutual inductance)、F1-10(no-load excitation current), motor tuning is finished. If over-current happens, please increase F7-00、F7-01 properly.

If the motor cannot be non-loaded, set F1-11 to 1 (static tuning), then press RUN, the motor will run automatically. In this situation, the inverter will only measure 3 parameters in turn: stator resistance, rotator resistance and leakage inductance. But mutual inductance can be calculated through no-load current.

▲ Permanent-magnet synchronous motor parameter automatic tuning steps are as follows:

- (1) Set F0-01 to 0: choose operation panel command channel control as the control mode;
- (2) According to the actual type of the motor set F1-00 to 1: Permanent-magnet synchronous motor. Then set F1-01、F1-02、F1-03、F1-04、F1-05 according to motor nameplate;
- (3) Cut all the wires and loads of the elevator, then set F1-11 to 2 (complete tuning), and press RUN, the motor will run automatically. When the inverter has calculated FA-04、FA-05 polarity angle of pulse wheel encoder, motor tuning is finished.
- (4) When tuning is over, set F0-03=10.00Hz, and press RUN. Then check if it's running normally, if there's anything strange, please repeat the upper 1,2,3 steps to change the signal direction of the pulse wheel encoder.

6.3 F2 Vector control factors

F2-00	Speed loop proportional factor 1		Factory default	35
	Setting range	0~100		
F2-01	Speed loop integral time 1		Factory default	0.60s
	Setting range	0.01s~10.00s		
F2-02	Switching frequency 1		Factory default	2.00Hz
	Setting range	0.00~F2-05		
F2-03	Speed loop proportional factor 2		Factory default	30
	Setting range	0~100		
F2-04	Speed loop integral time 2		Factory default	0.8s
	Setting range	0.01s~10.00s		
F2-05	Switching frequency 2		Factory default	5.00Hz
	Setting range	F2-02~Maximum output frequency		

F2-00 and F2-01 are the PI adjustment parameters when running frequency is lower than switching frequency 1(F2-02); F2-03 and F2-04 are the PI adjustment parameters when running frequency is higher than switching frequency 2(F2-05); The PI adjustment parameter between switching frequency 1 and switching frequency 2 is the weighted average of F2-00、F2-01 and F2-03、F2-04. Refer to the following figure:

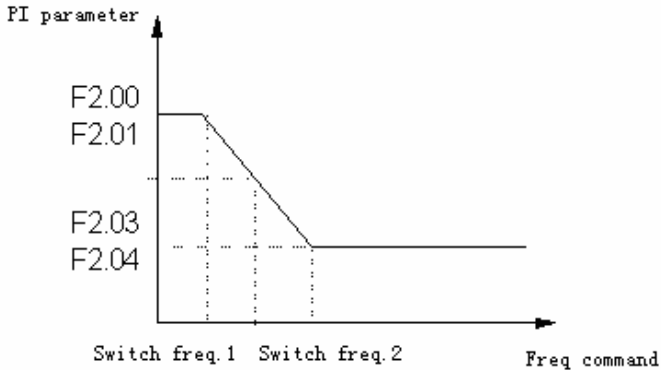

Fig 6-1 PI parameters

Setting proportional factor and integral time of speed adjustor can adjust speed dynamic response property of vector control. Increasing proportional gain or reduce integral time can make dynamic response of speed loop faster. But too large proportional gain or too little integral time may bring asscillation to the system.

Suggested adjusting way:

If factory default parameters cannot meet the requirements, trimming can be conducted on the basis of the default: first increase proportional gain to ensure ther's no system asscillation, then reduce the integral time, which will bring system a faster response property, and the overshoot will be smaller.

If switching frequency 1 and switching frequency 2 are 0 at the same time, then only F2-03 and F2-04 are effective.

Note: Improper PI setting may result in too large speed overshoot, even result in over-voltage fault when overshoot decreases.

F2-06	Current loop proportional gain		Factory default	60
	Setting range	10~300		
F2-07	Current loop integral gain		Factory default	30
	Setting range	10~30		

F2-06, F2-07 are the adjusting parameters of current loop in vector control arithmetic, the adjusting method is similar with PI parameters.

F2-08	Upper limit of torque		Factory default	150%
	Setting range	0%~200%		

It's ME320L(N) inverter output torque current limit, and also the upper limit of the pre-torque compensation.

6.4 F3 Startup/stop control parameters

F3-00	Startup frequency		Factory default	0.00Hz
	Setting range	0.00Hz~10.00Hz		

In order to increase the torque during elevator start-up, proper startup frequency should be set. Setting startup frequency hold time will generate magnetic flux. The function works when ME320L(N) inverter is under multi-stage speed control, but not digit setting, analog setting, communication setting and others.

F3-01	Torque output delay		Factory default	0.20s
	Setting range	0.00s~10.00s		
F3-02	Brake open delay		Factory default	0.10s
	Setting range	0.00s~10.00s		
F3-03	Zero-speed delay		Factory default	0.30s
	Setting range	0.00s~10.00s		
F3-04	Startup time		Factory default	0.00s
	Setting range	0.00s~10.00s		
F3-05	Startup frequency hold time		Factory default	0.00s
	Setting range	0.00s~10.00s		
F3-06	Brake release delay		Factory default	0.20s
	Setting range	0.00s~10.00s		
F3-07	Stall release delay		Factory default	0.30s
	Setting range	0.00s~10.00s		
F3-08	Running contactor release delay		Factory default	0.00s
	Setting range	0.00s~10.00s		

Setting F3-01~F3-08 can profoundly adjust elevator startup and stop comfortability. Precise meaning of each function code refers to the following Fig (take multi-stage speed running as sample):

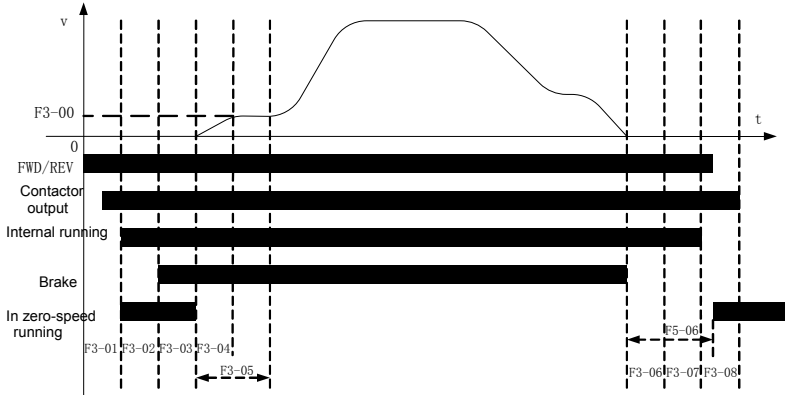

Fig 6-2 Running sequence

F3-09	Startup pre-torque setting selection		Factory default	0
	Setting range	0: No pre-torque		
		1: DI setting		
		2: AI1 setting		
		3: AI2 setting		
		4: Use pre-torque initial bias		
5: No weighing compensation				

ME320L(N) inverter has altogether 4 pre-torque ssetting selections, in which DI setting, AI1 setting, AI2 setting can only be used with the help of weighing sensor. When pre-torque compensation function is being applied, the system can ouput suitable to elevator load torque in advance to ensure comfortable sense during brake opening. Output pre-torque is confined by the upper limit (F2-08) . When calculated pre-torque is bigger than F2-08, output torque is the upper limit F2-08.

If elevator has no weighing compensation, set F3-09 to 4, and then adjust pre-torque bias parameter of F3-12 to make ME320L(N) do pre-excitation fully before brake opening so as to improve the startup comfortability. But the parameter cannot be set too big, usually -15%~15%.

If automatic compensation function is applied, set F3-09 to 5, then adjust FD-05~FD-07 according to the actual situation, and revise corresponding factory default. Before using, these parameters must be confirmed. Adjust regularly on the basis of FD-05=15.0%、FD-07=0.50、FD-08=0.60.

F3-10	Pre-torque deviation		Factory default	50.0%
	Setting range	0.0%~100.0%		

F3-11	Pre-torque gain		Factory default	0.60
	Setting range	0.00~1.50		

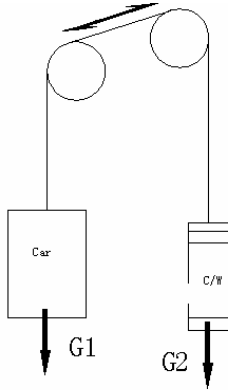

Pre-torque bias, elevator balance factor, refers to the percentage of elevator counterweight to rated weight. If $G1$ is no-load weight of the cage, $G2$ is counterweight, $G3$ is rated weight, then pre-torque bias (F3-10) = $(G2-G1) / G3$.

Suppose the weight of the things in the cage is $G4$, then motor pre-torque output is:

$$\text{Motor pre-torque output} = \text{pre-torque bias} * |G4 - (G3 * (\text{F3-10}))|$$

Fig 6-3 But output pre-torque direction has no relationship with running direction, it's only related to cage load. If cage load is bigger than $G3 * (\text{F3-10})$, output pre-torque is upward, otherwise, it's downward.

F3-12	Pre-torque initial bias		Factory default	10.0%
	Setting	-100.0%~100.0%		
F3-13	DI weighing signal 1		Factory default	10.0%
	Setting	0%~100.0%		
F3-14	DI weighing signal 2		Factory default	30.0%
	Setting	0%~100.0%		
F3-15	DI weighing signal 3		Factory default	70.0%
	Setting	0%~100.0%		
F3-16	DI weighing signal 4		Factory default	90.0%
	Setting	0%~100.0%		

ME320L(N) inverter can apply 3 pre-torque modes: digital weighing signal, analog weighing signal and pre-torque bias, in which F3-13~F3-16 are digital weighing signal settings. These

4 settings correspond to weighing terminals 1~4 one by one. Setting content of the 4 function parameters means the percentage of cage load when the signal is effective. For example, suppose when cage load has got to 10%, weighing signal1 is effective, thus set F3-13 to 10%. So when cage load is more than 10%, ME320L(N) inverter can identify current cage load through weighing signal 1, and then relize pre-torque function. If more than one signal is effective, the signal showing bigger cage load is effective.

F3-17	Weighing analog input filtering time		Factory default	0.10s
	Setting	0.00s~1.00s		
F3-18	Weighing analog no-load corresponding input		Factory default	0.00V
	Setting	0.00V~10.00V		
F3-19	Weighing analog full-load corresponding input		Factory default	10.00
	Setting	0.00V~10.00V		

When F3-08 chooses analog AI1 or AI2 setting, it means ME320L(N) inverter applies analog weighing signal input. F3-17 is the filtering time of the signal, proper increase of which can improve anti-jamming ability of the weighing signal.

When applying analog weighing signal input, corresponding input voltages to no-load and full-load cage input voltages should be set accurately to ensure accurate pre-torque compensation.

Diagram of pre-torque theory is as follows:

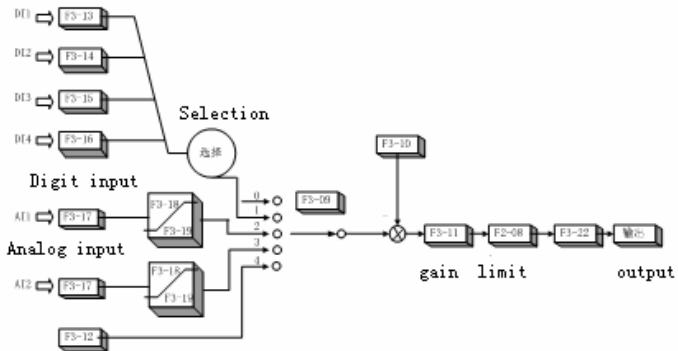

Fig6-4

F3-20	Analog weighing self-learning		Factory default	0
	Setting	0~100		
F3-21	Analog weighing self-learning selection		Factory default	0

	Setting range	0: No operation 1: Self-learning permitted.
--	---------------	--

In the situation of analog weighing input, self-learning can be done, that is to record the no-load and full-load data in F3-18, F3-19 with the change of the cage load.

Operation is as follows:

- 1, Make sure F3-21 is set to 1, and that F3-09 choose 2 or 3 to permit self-learning.
- 2, Stop the elevator on any floor when cage is no-load, input F3-20 setting value 0, and press ENTER to input;
- 3, Let cage be N% loaded, set F3-20=N, and press ENTER to input. For example: when 100kg load is put in the elevator whose rated load is 1000kg, input F3-20=10, then weighing self-learning is finished.

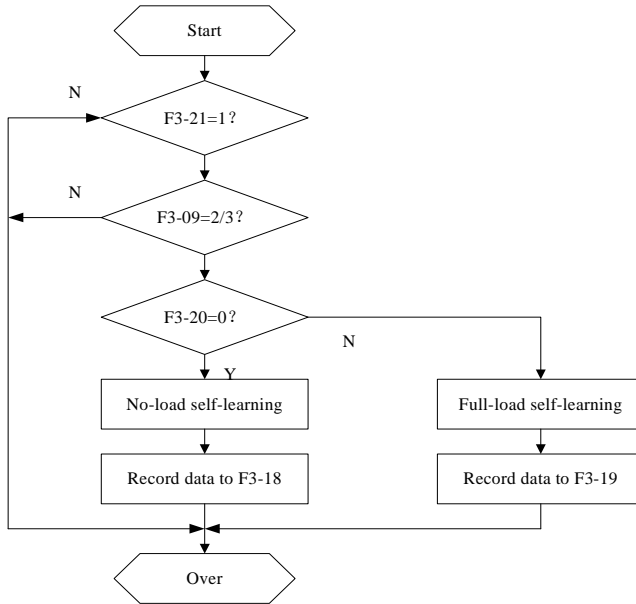

Fig 6-5

Note: 1. In the process of self-learning, F3-21 should be set to 1, but when self-learning is finished, it to 0; 2. No-load self-learning must be done before full-load self-learning, otherwise the data will be wrong.

F3-22	Pre-torque direction reversing		Factory default	0
	Setting range	0: No change		

		1: Reverse the direction
--	--	--------------------------

The direction can be reversed through this function code without changing the value of pre-torque.

6.5 F4 Group Input terminal

ME320L(N) inverter standard unit has 5 multi-functional digit input terminal (DI5 can be used as high-speed pulse input terminal) and 2 analog input terminal.

Multi-functional I/O expansion card has 5 multi-functional digit input terminal and 1 analog input terminal.

F4-00	DI filtering time		Factory default	0.020s
	Setting range	0.000s~0.200s		

It's used to set the sensitivity of DI terminal. If digit input terminal is easy to be interfered, which results in false action, this parameter can be increased to improve anti-jamming ability. But in this situation the sensitivity of DI terminal will decrease.

F4-01	DI1 terminal function selection	Factory default	1 (Forward running)
F4-02	DI2 terminal function selection	Factory default	2 (Reverse running)
F4-03	DI3 terminal function selection	Factory default	3 (Multi-speed 1)
F4-04	DI4 terminal function selection	Factory default	4 (Multi-speed 2)
F4-05	DI5 terminal function selection	Factory default	5 (Multi-speed 3)
F4-06	DI6 terminal function selection	Factory default	6 (Fault reset)
F4-07	DI7 terminal function selection	Factory default	7 (Enable control)
F4-08	DI8 terminal function selection	Factory default	0
F4-09	DI9 terminal function selection	Factory default	0
F4-10	DI10 terminal function selection	Factory default	0

F4-01 ~ F4-10 are used to set the corresponding function of multi-functional digit input terminal. Detailed functions are as follows:

Setting value	Function	Explanation
0	No function	Even if there's input signal, the inverter would not operate. Terminals which are not used can be set to "No function" to prevent false action.
1	Forward running command (FWD)	Changing inverter running direction, forward or reverse, through external terminal can realize upward or downward running of the elevator. Note: Every time the running is finished, the command terminal must be cut once,

Setting value	Function	Explanation
2	Reverse command (REV)	otherwise the elevator cannot continue running.
		FWD REV Command meaning
		OFF OFF Ineffective
		ON OFF Forward
		OFF ON Reverse
ON ON Ineffective		
3	Multi-speed terminal 1 (K1)	8-stage speed can be set though the number combination of the 3 terminals. Detailed combinations refer to the following table.
4	Multi-speed terminal 2 (K2)	
5	Multi-speed terminal 3 (K3)	K3 K2 K1 Frequency setting Corresponding parameter
		OFF OFF OFF Multi-speed 0 F6-00
		OFF OFF ON Multi-speed 1 F6-01
		OFF ON OFF Multi-speed 2 F6-02
		OFF ON ON Multi-speed 3 F6-03
		ON OFF OFF Multi-speed 4 F6-04
		ON OFF ON Multi-speed 5 F6-05
		ON ON OFF Multi-speed 6 F6-06
		ON ON ON Multi-speed 7 F6-07
6	Fault reset input	External fault reset function. Same with the function of RESET on the keyboard, which can realize the automatic reset of elevator fault function.
7	Enable control input	Running enable terminal is set. When running enable signal disappears, the inverter will stall at once, outputting brake close command.
8	Inspection input	When inspection input is effective, ME320L(N) selects multi-stage speed according to the non-zero parameters in F6-16. In stalling process, if the signal input by inspection is removed first, ME320L(N) will decelerate to 0 during the deceleration time set in F6-16 until forward or reverse running command is cancelled; if forward or reverse running command is cancelled directly, ME320L(N) will stop outputting at once.
9	Emergency input	Emergency input shows that the elevator has been in emergency running condition. It's running with external 48V battery power or 220V UPS input.
10	Running contactor feedback input	Contactor feedback terminal and brake feedback terminal will start to test contactor feedback signal and brake feedback signal in 2 seconds after the elevator is stopped (after contactor disconnected signal is output). If the two signals still exist, the inverter will output that conglutination signal is effective. If feedback signals are selected, ME320L(N) will monitor them constantly in running process.
11	Brake feedback input	
12	Weighing terminal 1 input	Correspond to digital weighing signals, relative setting parameters are in F3-12~F3-15.
13	Weighing terminal 1 input	

Setting value	Function	Explanation
14	Weighing terminal 1 input	
15	Weighing terminal 1 input	
16	External fault input	External fault input point. When the signal is effective, the system will alarm and stop running.
17	Motor over-heated input	After DI terminal is set to 17 or 117 (motor overheat normal open/ normal closed input) , when corresponding digital terminal signal is effective, it's motor overheat protection. Otherwise, the motor overheat fault will reset automatically.
18	Upward speed judgment input	Forced deceleration function can be realized through these two signals and with the help of FC-02、FC-03. In upward running process if upward speed judgment switch (force deceleration switch) has had action, ME320L(N) will compare current running frequency with FC-02, if it's bigger than FC-02, ME320L(N) will decelerate at once (according to the time setting in FC-01),, which will ensure the safety of the elevator. Downward running is the same. Details refer to FC group explanation.
19	Downward speed judgment input	

Note: Terminal input range is 0~119, in which 1 on the hundred bit means the signal is normal close, while 0 means it's normal open. The lower 2 bits are the terminal input function selection. The function is ineffective when it's bigger than 19. for example: 106 means terminal function is fault reset, and the signal is normal closed.

F4-13	Multi-stage speed filtering time		Factory default	0.020s
	Setting range	0.000s~0.200s		

When elevator is running, multi-stage speed command is given by external controller. If the command is wrong because of relay delay or discreteness of the controller interface, it will result in strange running curve of the elevator. Through F4-13 multi-stage speed can be filtered so as to get rid of the wrong command in multi-stage speed switching process. As the following figure:

Fig 6-6

6.6 F5 Group Output terminal

ME320L(N) inverter standard unit has 1 multi-functional digital output terminal (open-collector), 1 FM terminal (open-collector) , 1 multi-functional relay output terminal, 1 multi-functional analog output terminal. If relay output terminal need to be added, multi-functional I/O expansion card is needed. Expansion card also has 1 multi-functional analog output terminal.

F5-00	FMR output selection (open-collector output terminal)	Factory default	15 (running is fully prepared)
F5-01	DO1 output selection (open-collector output terminal)	Factory default	3(zero-speed signal)
F5-02	DO2 output selection (open-collector output terminal)	Factory default	0 (No output)
F5-02	RELAY1 output selection (relay 1 output terminal)	Factory default	4 (Fault signal)
F5-03	RELAY2 output selection (relay 2 output terminal)	Factory default	0 (No output)

Function explanations are as follows:

Setting value	Function	Explanation
0	No output	The terminal has no function.
1	Running	Shows the inverter is running, at this time ON signal is output.
2	Zero-speed running	When inverter is in zero-speed running, the signal is effective.
3	Zero-speed signal	When inverter output frequency is 0 or it's in stop, the signal is effective.
4	Fault signal	Effective when inverter has fault.
5	Running contactor output control	Output and control the action of contactor.
6	Brake output control	Output and control the action of brake contactor.
7	Advanced dooropen signal	Effective when the output frequency is smaller than FC-04 during deceleration of the inverter.
8	Bus undervoltage	When bus voltage is lower than 280V, ME320L(N) inverter will output bus undervoltage signal to realize battery running conveniently.
9	FDT 1 output	Refer to parameter explanation of FC group.
10	FDT 2 output	
11	Frequency arrival	
12	Oeve-speed output	When inverter running frequency is higher than FC-09, and hold time is longer than FC-10, ME320L(N) will output over-speed signal.
13	Over-load pre-alarm	Before motor electronic heat protection, Judge on the overload alarm value. Output ON signal when exceed the rated value. The parameter set as F9-00-F9-02
14	Running time arrival	When accumulated running time of inverter is more than F8-08. ON signal will be output.
15	Running prepared	When inverter is able to run, ON signal will be output.

16	Contact conglutination output control	When contact conglutination is found, ON signal will be output.	
F5-06	Zero-speed output delay time	Factory default	0.000

When 2 (zero-speed running) is chosen, delay time of the output signal is decided by F5-06. corresponding relation refers to Fig6-2.

F5-07	AO output selection	Factory default	1
--------------	----------------------------	-----------------	---

Main control board of ME320L(N) has a analog output terminal (AO1) , F5-07 is for the selection of this analog output.

Standard output (zero bias is 0, gain is 1) of analog output is 0mA~20mA (or 0V~10V) , the range of corresponding elements are in the following table:

Setting value	Function	Range
0	Running frequency	0~Maximun output frequency
1	Setting frequency	0~Maximun output frequency
2	Output current	0~2 times the rated current of inverter
3	Output torque	0~2 times the rated current of motor
4	Output voltage	0~1.2 times the rated voltage of inverter
5	AI1	0V~10V
6	AI2	0V~10V/0mA~20mA

F5-08	AO bias factor		Factory default	0.00%
	Setting range	-100.0%~100.0%		
F5-09	AO gain		Factory default	1.00
	Setting range	-10.00~10.00		

If bias is "b", gain is k, actual output is Y, standard output is X, then actual output is:

$$Y=kX+b;$$

AO bias factor 100% corresponds to 10V (20mA) .

Standard output indicates output 0V~10V (20mA) , corresponding analog output: 0~maximum.

Usually used to revise the zero drift of analog output and deviation of output amplitude. Can also be self-difined as curve needing to be output.

For example: If analog output is running frequency, set gain to "-0.50", bias to "80%", then when frequency is 0, output will be 8V (16mA) , and when frequency is maximum frequency, output will be 3V (6mA) .

6.7 F6 Group Speed parameters

When ME320L(N) chooses multi-stage speed running, F6-00~F6-15 need to be set to define curve running characteristic.

F6-00	Multi-stage speed 0		Factory default	0.0Hz
	Setting	0.00Hz~Maximum frequency		
F6-01	Multi-stage speed 1		Factory default	0.0Hz
	Setting	0.00Hz~Maximum frequency		
F6-02	Multi-stage speed 2		Factory default	0.0Hz
	Setting	0.00Hz~Maximum frequency		
F6-03	Multi-stage speed 3		Factory default	0.0Hz
	Setting	0.00Hz~Maximum frequency		
F6-04	Multi-stage speed 4		Factory default	0.0Hz
	Setting	0.00Hz~Maximum frequency		
F6-05	Multi-stage speed 5		Factory default	0.0Hz
	Setting	0.00Hz~Maximum frequency		
F6-06	Multi-stage speed 6		Factory default	0.0Hz
	Setting	0.00Hz~Maximum frequency		
F6-07	Multi-stage speed 7		Factory default	0.0Hz
	Setting	0.00Hz~Maximum frequency		

3-bit digit input terminal (multi-stage speed terminal 1~3) can be used to set 8 kinds of speeds. At this time speed selection F0-02 is set to 1, chosen digit input terminals are defined one by one as 3, 4, 5, shown as K1, K2, K3.

The following table show the relationship between digit input terminal and corresponding speed:

K3	K2	K1	Frequency setting	Corresponding parameter
OFF	OFF	OFF	Multi-stage speed 0	F6-00
OFF	OFF	ON	Multi-stage speed 1	F6-01
OFF	ON	OFF	Multi-stage speed 2	F6-02
OFF	ON	ON	Multi-stage speed 3	F6-03
ON	OFF	OFF	Multi-stage speed 4	F6-04
ON	OFF	ON	Multi-stage speed 5	F6-05
ON	ON	OFF	Multi-stage speed 6	F6-06
ON	ON	ON	Multi-stage speed 7	F6-07

That is to say, target frequency of ME320L(N) current running can be chosen through multi-stage speed terminal combinations. For example, when multi-stage speed terminal combination is 2, ME320L(N) will take F6-02 as target frequency of current running. As a

result, in the application of elevator controller chooses different multi-stage speed combinations according to the actual situation, and inputs them to ME320L(N) to control the running speed of the elevator.

F6-08	Multi-stage speed 0 acceleration time selection	Factory default	1
	Setting range	1~4	
F6-09	Multi-stage speed 1 acceleration time selection	Factory default	1
	Setting range	1~4	
F6-10	Multi-stage speed 2 acceleration time selection	Factory default	1
	Setting range	1~4	
F6-11	Multi-stage speed 3 acceleration time selection	Factory default	1
	Setting range	1~4	
F6-12	Multi-stage speed 4 acceleration time selection	Factory default	1
	Setting range	1~4	
F6-13	Multi-stage speed 5 acceleration time selection	Factory default	1
	Setting range	1~4	
F6-14	Multi-stage speed 6 acceleration time selection	Factory default	1
	Setting range	1~4	
F6-15	Multi-stage speed 7 acceleration time selection	Factory default	1
	Setting range	1~4	

ME320L(N) inverter provides four groups of acceleration time, details refer to F7 group. F6-08~F6-15 can set acceleration and deceleration time of each stage speed separately, 1~4. Thus when elevator is running in different state, different curves have different acceleration and deceleration time.

Especially note: In acceleration situation, acceleration time of target speed and S curve of the speed is applied, while in deceleration situation, acceleration time of starting speed and its S curve should be applied.

For example: F6-01=0 Hz; F6-03=8 Hz; F6-05=48 Hz; F6-09=2; F6-11=3; F6-13=4, when speed need to increase from F6-01 to F6-05, acceleration time should be 4 (F7-12) chosen by F6-13; when speed need to decrease from F6-05 to F6-03, deceleration time should be 4 (F7-13) chosen by F6-13; when speed need to increase from F6-01 to F6-05, acceleration time should be 4 (F7-12) chosen by F6-13, when it continues to decrease to F6-01, acceleration time should be 3 (F7-09) chosen by F6-11.

This is the process of one running in multi-stage speed control. In this process acceleration and deceleration time of high speed are usually set to 3~4 seconds, but from creep to stop, deceleration time can be different from regular deceleration time. In this example, increase F7-05 properly can ensure smooth transition of speed during stalling. As the following figure:

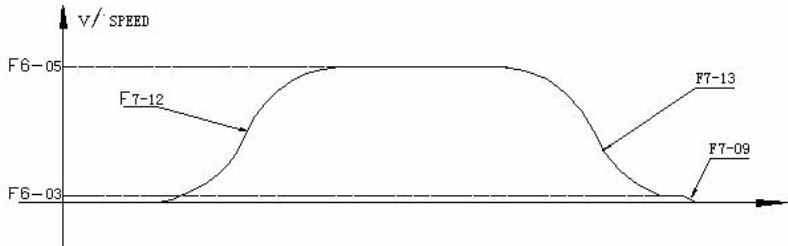

Fig 6-7

ME320L(N) can provide many different acceleration and deceleration curves through the combination of 8 multi-stage speed parameters and 4 time parameters.

F6-16	Inspection speed selection		Factory default	0
	Setting range	0~7		

This code sets the multi-stage speed in the process of inspection, details refer to Chapter 7.

F6-17	Power failure emergency rescue		Factory default	0
	Setting range	0	No running	
		1	Running powered by UPS	
		2	Running powered by 48V battery	

Details refer to power failure emergency running in Chapter 7.

F6-18	Analog minimum input		Factory default	0.00V
	Setting range	0.00V~10.00V		
F6-19	Corresponding setting of analog minimum input		Factory default	0.0%
	Setting range	0.0%~100.0%		
F6-20	Analog maximum input		Factory default	10.00V
	Setting range	0.00V~10.00V		
F6-21	Corresponding setting of analog maximum input		Factory default	100.0%
	Setting range	0.0%~100.0%		
F6-22	Analog input filtering time		Factory default	0.10s
	Setting range	0.00s~1.00s		

The above function codes define the speed setting of ME320L(N) inverter under analog control mode and the relationship between analog input voltage and setting value represented by analog input. When analog voltage is beyond the setting range, take it as maximum input or minimum input.

When analog input is current input, 1mA current is the same like 0.5V voltage.

If F0-02 is set to A11 or A12, then this speed channel will work out the percentage parameter

of speed to maximum frequency from F6-18~F6-22. The parameter is current speed setting.

F6-23	Inverter function selection		Factory default	0
	Setting range	0~65535 BIT0: 1: reduce current to 0 in (F6-26+250) ms during normal stalling; 0: initial stalling mode		

When BIT0 of F6-23 is 1, current will decrease to 0 in (F6-26+250) ms after brake is over and running signal is cut during normal stalling.

F6-24	Motor overheat voltage setting		Factory default	0.0V
	Setting range	0.00V~10.00V;		

In this mode AI2 terminal is to judge motor overheat all the time. When F6-24 is set to non-zero:

When motor is overheated, it is not judged according to the input terminal function in F4 group. If input voltage of AI2 terminal is always bigger than setting value of F6-24 (filtering time is 0.5s), inverter will alarm for Err39 motor overheat protection; If input voltage of AI2 terminal is always smaller than setting value of F6-24 (filtering time is 2s), motor overheat fault will reset automatically.

As resistance of thermistor R2 is 1.33k, it is suggested to set R1 to 2.0k, and F6-24 to 3.9V. its wiring is as follows:

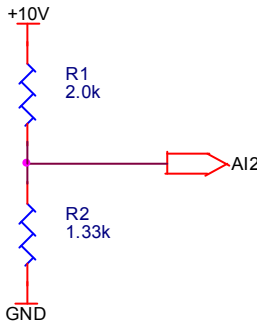

Fig 6-8

Connection to the inverter: +10V、GND、AI2 in the above figure should be connected to +10V、GND、AI2 on the control board of inverter respectively.

F6-25	Auxiliary function selection		Factory default	0
	Setting range	0~9999		

BIT3 of F6-25 is set to 0: Cancel no-weighing startup function, otherwise emergency running

will also be no-weighing startup.

F6-26	Stop current withdraw time		Factory default	100ms
	Setting range	0~9999ms		

It's used to remove current noise of motor in stop, to reduce current to 0 in (F6-26+250) ms after brake is over and running signal is cut during normal stalling.

Zero-speed signal output delay is added to control board. Function code of delay time is F6-27:

F6-27	Zero-speed signal output delay		Factory default	0
	Setting range	0~9999ms		

6.8 F7 Group Curve parameters

ME320L(N) inverter has altogether 4 groups of acceleration and deceleration time corresponding to the 4 groups of S curves. Every S curve can be set according to the need of users.

F7-00	Acceleration time 1		Factory default	4.0s
	Setting range	1.0s~100.0s		
F7-01	Deceleration time 1		Factory default	4.0s
	Setting range	1.0s~100.0s		
F7-02	Proportion of S curve 1 start segment		Factory default	40.0%
	Setting range	10.0%~40.0%		
F7-03	Proportion of S curve 1 end segment		Factory default	40.0%
	Setting range	10.0%~40.0%		

F7-04	Acceleration time 2		Factory default	4.0s
	Setting range	1.0s~100.0s		
F7-05	Deceleration time 2		Factory default	4.0s
	Setting range	1.0s~100.0s		
F7-06	Proportion of S curve 2 start segment		Factory default	40.0%
	Setting range	10.0%~40.0%		
F7-07	Proportion of S curve 2 end segment		Factory default	40.0%
	Setting range	10.0%~40.0%		

F7-08	Acceleration time 3		Factory default	4.0s
	Setting range	1.0s~100.0s		

F7-09	Deceleration time 3		Factory default	20.00s
	Setting range	1.0s~100.0s		
F7-10	Proportion of S curve 3 start segment		Factory default	40.0%
	Setting range	10.0%~50.0%		
F7-11	Proportion of S curve 3 end segment		Factory default	40.0%
	Setting range	10.0%~50.0%		

F7-12	Acceleration time 4		Factory default	1.0s
	Setting range	0.5s~100.0s		
F7-13	Deceleration time 4		Factory default	1.0s
	Setting range	0.5s~100.0s		
F7-14	Proportion of S curve 4 start segment		Factory default	40.0%
	Setting range	10.0%~50.0%		
F7-15	Proportion of S curve 4 end segment		Factory default	40.0%
	Setting range	10.0%~50.0%		

The meanings of these four groups of time are the same. Acceleration and deceleration time of the speed of each stage and S curve characteristics can be set through F6-08~F6-15.

Acceleration time refers to the time t1 for inverter to accelerate from 0Hz to maximum frequency (F0-05) .

Deceleration time refers to the time t2 for inverter to decelerate from maximum frequency (F0-05) to 0Hz.

As in following figure:

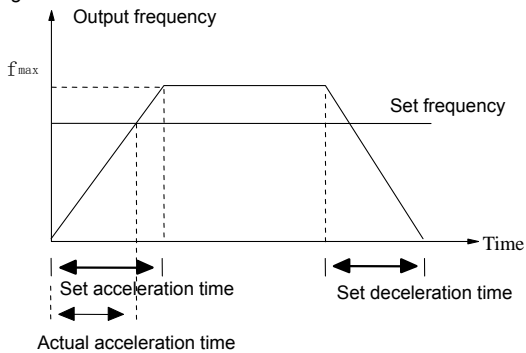

Fig 6-9 Acceleration and deceleration time

When setting frequency is maximum frequency, actual acceleration and deceleration time is setting value.

When setting frequency is smaller than maximum frequency, actual acceleration and

deceleration time = setting value × (setting frequency / maximum frequency) .

ME320L(N) inverter has 4 different S curves, and in each one acceleration and deceleration segments are symmetrical. The following figure is S curve 1: T1 is the time defined by F7-02, during this time output frequency change slope (speed change rate) keeps on increasing. T2 is the time defined by F7-03, during which output frequency change slope reduces to 0 regularly. Between T1 and T2, output frequency change slope is fixed.

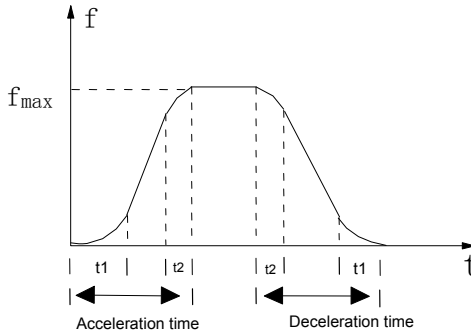

Fig 6-10 Acceleration and deceleration of S curve 1

As a result, when ME320L(N) inverter is under multi-stage speed control, switching the multi-stage speed combinations can change S curve in different time segments, which ensures reasonable speed change of elevator in running to enhance comfortability.

6.9 F8 Group Keyboard parameters

F8-00	I/O terminal state indication	Factory default	No
	Setting range	No	

F8-00 refers to I/O terminal state. Nixie tubes from left to right are 5, 4, 3, 2, 1, meaning of segment of the nixie tubes is as follows:

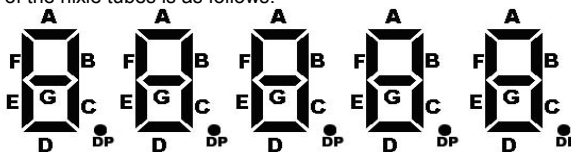

Bits 3, 4, 5 are I/O terminal input and output state of inverter, they are shown in numerical code; bit 1 is in numeral mode; bit 2 is reserved.

Meaning of each segment of nixie tube is as follows:

Order	Mark in nixie tube	Meaning when nixie tube is light
1	0	Holding state

Order	Mark in nixie tube	Meaning when nixie tube is light
	1	Contactor brake control
	2	Torque output delay
	3	Strange speed treatment
	4	Normal curve running
	5	Reserved
	6	Startup frequency processing
	7	Contactor processing in stalling
	8	Fault processing
	9	Deceleration processing
	A	Stall zero-speed hold
	B	Stall brake processing
	C	Stop
3	A	X1 input is effective (effective refers to that normal open input close up, while normal closed input open)
	B	X2 input is effective
	C	X3 input is effective
	D	X4 input is effective
	E	X5 input is effective
	F	X6 input is effective
	G	X7 input is effective
	DP	X8 input is effective
4	A	X9 input is effective
	B	X10 input is effective
	C~F~DP	Reserved
5	A	FM output is effective
	B	DO1 output is effective
	C	DO2 output is effective
	D	Relay1 output is effective
	E	Relay2 output is effective
	F~H~DP	Reserved

F8-01	LED running displayed parameters		Factory default	32767
	Setting range	1~32767		

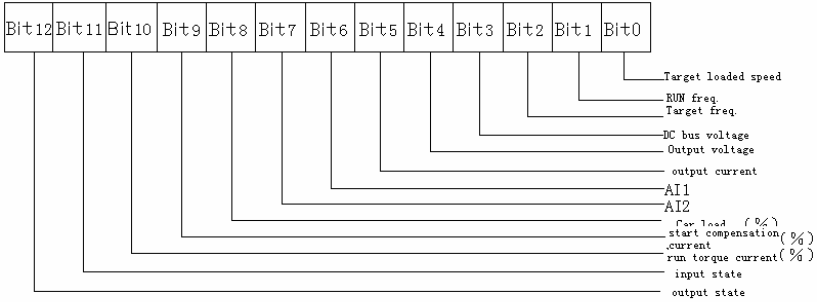

In running if above parameters need to be displayed, set F8-01 to the decimal transferred from the binary on the bit of the parameter.

F8-02	LED stop displayed parameters	Factory default	0
	Setting range	1~255	

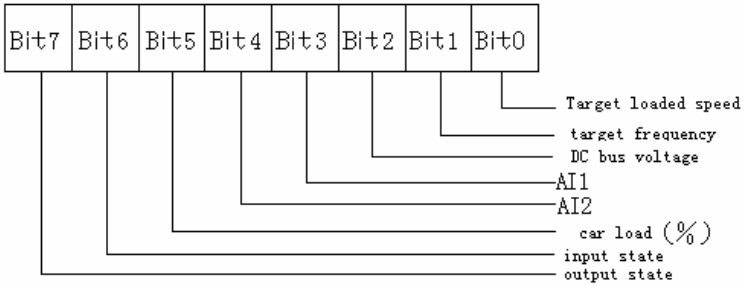

When ME320L(N) stops, if above parameters need to be displayed, set F8-02 to the decimal transferred from the binary on the bit of the parameter.

F8-03	Load speed display factor	Factory default	0.32
	Setting range	0.01~100.00	

Through this parameter inverter output frequency and load speed can correspond to each other. Users are more familiar to the unit m/s, so it will be OK to set this parameter by proportion. For example, maximum output frequency of traction machine of 1.600m/s elevator is 50.00Hz, then $F8-03 = 1600 \div 5000 = 0.32$.

F8-04	Temperature of radiator	Factory default	
--------------	--------------------------------	-----------------	--

	Setting range	0.0℃～100.0℃
--	---------------	-------------

It displays the temperature of the radiator contacting the inverse module IGBT. IGBT overheat protection value may vary with the models. ME320L(N) inverter possesses inside automatic processing program.

F8-05	Software version 1		Factory default	
	Setting range	0～99.99		
F8-06	Software version 2		Factory default	
	Setting range	0～99.99		

F8-05 represents software version of control panel.

F8-06 represents software version of motor control panel.

F8-07	Setting running time		Factory default	0
	Setting range	0h～65535h		

It presets running time of the inverter.

When accumulated (F8-08) gets to this setting running time, inverter multi-functional digit terminal DO outputs arrival signal and stops running.

If F8-07 is set to 0, this function is ineffective.

F8-08	Accumulated working time		Factory default	0
	Setting range	0h～65535h		
F8-09	Accumulated second timing		Factory default	0
	Setting range	0s～3600s		

Accumulated working time is ME320L(N) inverter accumulated running time.

F8-10	High bit of running times		Factory default	0
	Setting range	0～9999		
F8-11	Low bit of running times		Factory default	0
	Setting range	0～9999		

When ME320L(N) inverter is under elevator running mode (not operation panel control), running times will increase by 1 after each running. When low bit of the running times is more than 9999, it will enter high bit. As a result 1 in F8-10 represent that actual running times is 10000.

F8-12	Grounding short protection testing during power-on		Factory default	0
	Setting range	0	Ineffective	
		1	Effective	

It decides whether the inverter is grounded short during power-on. check if the wire has ground shorted. If this function is effective, the inverter has short-time output at the moment of power-on.

6.10 F9 Group Fault and protection

F9-00	Motor overload protection selection		Factory default	1
	Setting range	0	Forbid	
		1	Permit	

0: Inverter has no overload protection of the loaded motor. At this time thermal relay should be added to the loaded motor.

1: Inverter has overload protection of the loaded motor. Protection value refers to F9-01.

F9-01	Motor overload protection gain		Factory default	1
	Setting range	0.20~10.00		

Motor overload protection is reverse time limit curve. When current is 150% the motor rated current: 1 minute; when it's 220% the motor rated current: 1 hour.

The value should be motor/inverter rated current. When inverter output current is more than F9-01× rated output current, in certain time inverter will alarm for motor overload fault.

F9-02	Motor overload pre-alarm factor		Factory default	80.0%
	Setting range	50%~100%		

Reference value of it is motor overload current. When inverter output current gets to F9-02× motor overload current, pre-alarm signal is output through DO or RELAY.

F9-03	Over-voltage stall ability		Factory default	0
	Setting range	0 (No over-voltage stall) ~100		

The bigger the value is, the stronger the over-voltage suppression ability will be.

For the load with small inertia the value should be small, or it will result in slower system dynamic.

For the load with big inertia the value should be big, or the suppression effect will be bad, which may result in over-voltage fault.

F9-04	Over-voltage stall protection voltage		Factory default	130.0%
	Setting range	120%~150%		

It's used to select over-voltage stall protection point. When the value is surpassed, the inverter will implement over-voltage stall protection.

F9-05	Over-current stall ability		Factory default	20
	Setting range	0~100		

It's used to adjust the ability of inverter to suppress over-current. The bigger the value, the

stronger the ability.

For the load with small inertia the value should be small, or it will result in slower system dynamic.

For the load with big inertia the value should be big, or the suppression effect will be bad, which may result in over-voltage fault.

F9-06	Over-current stall protection current		Factory default	150.0%
	Setting range	100%~200%		

It's used to select over-current stall protection point. When the value is surpassed, the inverter will implement over-current stall protection.

F9-07	Instantaneous stop non-stop function		Factory default	0
	Setting range	0	Forbid den	
		1	Permitted	

This refers to that when power is cut suddenly, the inverter will not stop. In the situation of sudden power-off or voltage lowering, the inverter reduces output speed, and compensates the lowering of the voltage with feedback energy of the load.

F9-08	Instantaneous stop non-stop frequency decreasing rate		Factory default	10.00Hz/s
	Setting range	0.00Hz~Maximum frequency/s		

It's used to set the lowered value of inverter output frequency in instantaneous stop non-stop function.

If the value is too small, load feedback energy will not be much enough to effectively compensate the voltage.

If the value is too big, load feedback energy will be too much, which may result in over-voltage protection.

Please adjust the parameter properly according to load inertia.

F9-09	Fault automatic reset times		Factory default	0
	Setting range	0~3		

When inverter chooses fault automatic reset, it's used to set the times of reset in one hour after fault happens. When actual times are more than the value, the inverter will be in fault and need mending.

F9-10	Fault relay action selection during fault automatic reset		Factory default	0
	Setting range	0	No action	

		1	Action
--	--	---	--------

When inverter has chosen fault automatic reset, in reset process whether fault relay has action is decided by the setting of the parameter, which will shield the fault alarm caused by this so as the equipment can continue running.

F9-11	Fault automatic reset interval		Factory default	1s
	Setting range	0.1s~100.0s		

The waiting time from inverter fault alarm and automatic reset.

F9-12	Input phase failure protection selection		Factory default	1
	Setting range	0	No protection	
1		Protection		

It's used to choose whether to protect input phase failure or not. (Only available for the models above 7.5kW).

F9-13	Output phase protection selection		Factory default	1
	Setting range	0	No protection	
1		Protection		

It's used to choose whether to protect output phase failure or not.

F9-14	First fault type		Factory default	-
F9-15	Second fault type		Factory default	-
F9-16	Last fault type		Factory default	-
	Setting range	0~24		

Details refer to Chapter 8.

F9-17	Frequency in fault		Factory default	-
F9-18	Current in fault		Factory default	-
F9-19	Bus voltage in fault		Factory default	-

Display frequency, current, bus voltage of the last fault.

F9-20	Input terminal in fault		Factory default	-
--------------	--------------------------------	--	-----------------	---

This value is decimal, displaying the state of all digit input terminals in the last fault. The order is:

Bit9	Bit8	Bit7	Bit6	Bit5	Bit4	Bit3	Bit2	Bit1	Bit0
------	------	------	------	------	------	------	------	------	------

DI10 DI9 DI8 DI7 DI6 DI5 DI4 DI3 DI2 DI1

If input terminal is ON and it's 1, then OFF is 0. Transfer each bit to decimal, then the information about current digit input signal can be got.

F9-21	Output terminal in fault		Factory default	-
--------------	---------------------------------	--	-----------------	---

This value is decimal, displaying the state of all digit output terminals in the last fault. The order is:

BIT4	BIT3	BIT2	BIT1	BIT0
------	------	------	------	------

DO2 DO1 REL2 REL1 FMP

If input terminal is ON and it's 1, then OFF is 0. Transfer each bit to decimal, then the information about current digit output signal can be got.

6.11 FA Group PG parameters

ME320L(N) inverter can apply not only asynchronous motor vector control, but permanent-magnet synchronous motor vector control. But as the control principles of motors are different, so different rotary encoders (PG) should be configured. Asynchronous motor can apply encoder push-pull or open-collector interfaces, while asynchronous motor need to use UVW rotary encoder with long-wire drive interface.

FA-00	PG pulse		Factory default	1024
	Setting range	0~65535		

Generally, in elevator application, rotary encoder is essential configuration of motor. FA-00 is the pulse number of each turn of rotary encoder. The parameter must be set correctly, otherwise, there may be over-current in running process.

FA-01	PG disconnection inspection time		Factory default	3.0s
	Setting range	0s~10.0s		

If PG pulse signal disappears in the running of the elevator, correct motor control can not be conducted. ME320 inverter is inspecting the pulse signal of rotary encoder all the time. If strange pulse signal is found lasting more than the time set in FA-01, ME320L(N) will output fault alarm (PG fault) and stop running. FA-01 is set less than 2.0s, alarm function is cancelled.

FA-02	PG type selection		Factory default	0
	Setting range	0	Reserved	
		1	Reserved	

Output signal of rotary encoder is quadrature pulse signal, so inverter can identify not only current motor running speed, but also the rotation direction. If the wiring of rotary encoder is not in accordance to that of the motor, control over-current or PG fault may also happen. When encoder can still no run normally although pulse is correctly set, please exchange the output phase sequence of A、B wires.

Through FA-02 ME320L(N) inverter can change its judgment of PG direction. If the wires are not in accordance, it will solve the problem to change FA-02.

Reversing the direction by FA-02 is the same with actual exchanging A,B phases of the encoder.

FA-03	Pole angle of pulse wheel encoder		Factory default	0
	Setting range	0~359.9		

When ME320L(N) inverter is conducting control on permanent-magnet synchronous motor, initial angle of UVW encoder is needed to identify position of motor rotator. In order to ensure high precision control in different directions, ME320L(N) records initial angle of PG through FA-03. The parameter of this function code comes from position identification of the rotary encoder. If users know the system, they can set themselves.

Only when this parameter is correctly set, can ME320L(N) inverter conduct the control of synchronous motor; but it's not needed for asynchronous motor control.

FA-03、05 (pole angle and wiring mode) must be changed in the condition of F0-01=0, otherwise it cannot be changed. And then F0-01 can be changed to 1 only after another power-on.

FA-04	Current angle of pulse wheel encoder		Factory default	0.0
	Setting range	0~359.9		

In permanent-magnet synchronous motor control UVW encoder will feedback the position of motor rotator to FA-04 of ME320L(N) inverter., which is crucial for high precision control of permanent-magnet synchronous motor.

FA-04 has power-off preserve function, and it's related only to synchronous motor, not to asynchronous motor.

FA-05	UVW wire mode		Factory default	0
	Setting range	0~3 (reserved)		

FA-05 is only for synchronous motor, which represents wiring combinations of the motor.

6.12 FB Group Communication parameters

Details refer to 《ME320L(N) Serial Communication Protocol》.

6.13 FC Group Special enhancement function

FC-00	Command abnormality action selection		Factory default	0
	Setting range	0	Normal deceleration to stop	
		1	Block output at once	

Command abnormality refers to the command given to ME320L(N) becomes ineffective suddenly in the running of elevator (Following figure). It will be handled according to the selection of FC-00. Normal deceleration to stop: the elevator stalls by logic deceleration according to normal control, keeping the speed of elevator changing smoothly without sudden reduction. Block output at once: close brake at once, cut the output of running contactor.

FWD	REV	Meaning of command
OFF	OFF	Ineffective
ON	OFF	Forward running
OFF	ON	Reverse running
ON	ON	Ineffective

FC-01	Abnormal deceleration time	Factory default	3.0
	Setting range	0s~300.0s	

It's used to set the time of strange deceleration.

FC-02	Upward running frequency inspection level	Factory default	45.00Hz
	Setting range	0.00Hz~Maximum frequency	
FC-03	Downward running frequency inspection level	Factory default	45.00Hz
	Setting range	0.00Hz~Maximum frequency	

FC-02, FC-03 the way of ME320L(N) inverter to realize forced deceleration. These two codes are the different judgment levels of elevator upward and downward running. (Note: Forward running corresponds to upward running; reverse running corresponds to downward running. In the input moment of upward (downward) frequency judgment signal (forced deceleration switch signal), ME320L(N) will inspect if current running frequency of inverter has surpassed the inspection level of FC-02 (FC-03). If has it will decelerate until stall according to the time setting of FC-01. Besides, during upward running, downward frequency judgment signal is ineffective, and vice versa.

So the principle of ME320L(N) forced deceleration is like the following figure:

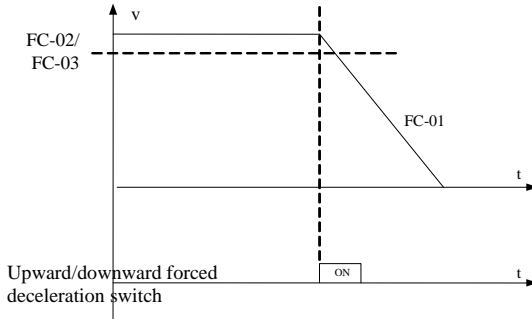

Fig 6-11

FC-04	Advanced dooropen judgment level	Factory default	5.00Hz
--------------	---	-----------------	--------

	Setting range	0.00Hz~Maximum frequency
--	---------------	--------------------------

ME320L(N) inverter can help realize advanced dooropen conveniently: when elevator is normally decelerating, if output frequency is lower than the parameter set in FC-04, ME320L(N) inverter will output advanced door-open signal through output terminal until stall.

FC-05	Frequency inspection level 1 (FDT level 1)	Factory default	50.00Hz
	Setting range	0.00~Maximum frequency	
FC-06	Frequency inspection level 2 (FDT level 2)	Factory default	50.00Hz
	Setting range	0.00~Maximum frequency	
FC-07	Frequency inspection delay (FDTdelay)	Factory default	5.0%
	Setting range	0.0%~100.0% (FDT level)	

As in the following picture: FC-05~FC-07 are relative parameters of FDT output signal, in which FDT1 and FDT2 can have two different setting values.

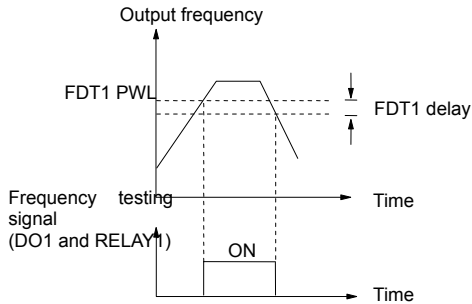

Fig 6-12

FC-08	Frequency arrival detection width	Factory default	1.00Hz
	Setting range	0.00Hz~50.00Hz	

When output frequency of the inverter has got to setting frequency, this function can adjust its detection amplitude. As in the following figure:

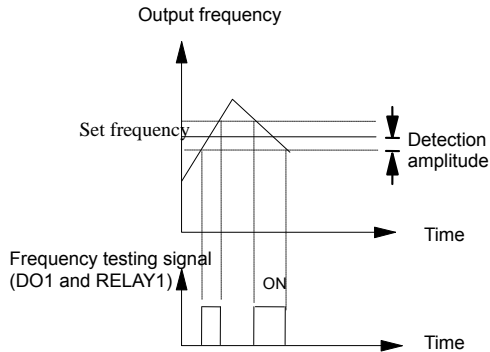

Fig 6-13

FC-09	Overspeed adjustment level		Factory default	115%
	Setting range	80%~120%		
FC-10	Overspeed detection delay		Factory default	1.0s
	Setting range	0.0s~5.0s		
FC-11	Overspeed action selection		Factory default	1
	Setting range	0	Abnormal deceleration to stall	
		1	Alarm at once, block output	
		2	Continue running	

ME320L(N) inverter has overspeed detection function, judging if the current running frequency is overspeed through the setting value of FC-09. If accumulated overspeed time is more than FC-10, the inverter is in overspeed state. Then ME320L(N) will take corresponding measure according to the setting of FC-11. Abnormal deceleration to stall is to decelerate to stall in the time of FC-01.

Overspeed judgment level is the percentage of maximum frequency, that is, 100% corresponds to the maximum frequency.

FC-12	Speed deviation judgment level		Factory default	30%
	Setting range	0%~50%		
FC-13	Speed deviation detection delay		Factory default	1.0s
	Setting range	0.0s~5.0s		
FC-14	Overlarge speed deviation action selection		Factory default	2
	Setting range	0	Abnormal deceleration to stall	
		1	Alarm at once, block output	
		2	Continue running	

ME320L(N) inverter has speed deviation detection function, judging if the deviation between current running frequency and setting frequency is overlarge through the setting value of FC-12. If accumulated time of overlarge deviation is more than FC-13, the system is in overlarge speed deviation state. Then ME320L(N) will take corresponding measure according to the setting of FC-14. Abnormal deceleration to stall is to decelerate to stall in the time of FC-01.

Speed deviation judgment level is the percentage of maximum frequency.

FC-15	Order selection of brake and running		Factory default	0
	Setting range	0	Output running first, and then brake control	
		1	Output brake control first, and then running	

Generally speaking, inverter output zero-speed running first before opening the brake. In this way in the moment of opening the brake excitation of motor has been completed, which can effectively avoid startup sliding. But as brake time of traction machine of some

elevators are too long, if just at this time pre-torque is output, it may result in start-up overcurrent. So in this situation FC-15 is set to 1.

6.14 FD Group Special function parameters

This group of codes are only for V/F control, not effective for vector control.

FD-00	Torque hoisting		Factory default	1.0%
	Setting range	0.1%~30.0%		
FD-01	Torque hoisting frequency		Factory default	50.00Hz
	Setting range	0~Maximum frequency		

In order to compensate low-frequency torque characteristic, it's needed to promote the output voltage of inverter when the frequency is low.

If torque hoisting is set too large, motor is easy to be overheated, and overcurrent happens to inverter easily. Generally, torque hoisting should not be more than 10%.

Adjusting this parameter effectively can get rid of startup overcurrent. If the load is too large, its suggested to increase the parameter, and reduce it when the load is small.

When torque hoisting is 0, inverter is set to automatic torque hoisting.

Thorque hoisting frequency: below this frequency, torque hoisting is effective, and above it torque hoisting is ineffective.

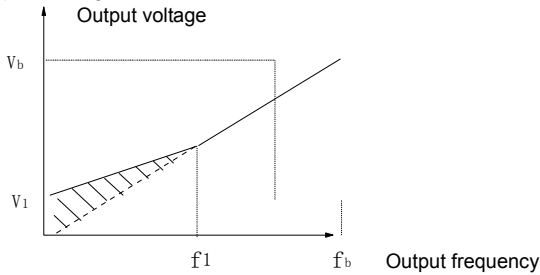

V1: Manual torque hoisting voltage
f1: Stop frequency of torque hoisting

Vb: Maximum output voltage
fb: Basic running frequency

Fig 6-14 Manual torque hoisting

FD-02	Slip compensation		Factory default	100.0%
	Setting range	0.0%~200.0%		
FD-03	Oscillation suppression gain		Factory default	20
	Setting range	0~100		

FD-02 is effective for V/F control. Setting this parameter can compensate the slip caused by load when the inverter is under V/F control, and reduce the variation of motor rotation speed with the change of load. Generally, 100% corresponds to the rated slip of motor with rated load. The following principles can be reference for adjusting the slip parameter: when the load is rated load, and slip compensation factor is set to 100%, rotation speed of the motor is

almost the given speed. If the load is lighter than rated load, this factor can be smaller than 100%, and when it's bigger than rated load, the factor can be a little bigger than 100%.

FD-03: oscillation suppression gain. It's 0 when the motor has no oscillation. When the motor has obvious oscillation and cannot run normally, increase the gain properly, and the bigger the parameter, the better the suppression effect. Way of setting it: set it as small as possible in the premise of effectively suppressing motor oscillation.

FD-05	Zero-servo current factor		Factory default	15.0%
	Setting range	1.0%~50.0%		
FD-06	Zero-servo speed loop KP		Factory default	0.50
	Setting range	0.05~1.00		
FD-07	Zero-servo speed loop TI		Factory default	0.60
	Setting range	0.05~2.00		

This group of parameters are used to adjust the startup of the elevator. Details refer to chapter 7.6.

6.15 FP Group User shortcut parameters

FP-00	User password		Factory default	0
	Setting range	0~65535		

Password function is effective if the parameter is not set to 0.

00000: clear previous password, and make password function ineffective.

When user password is set and it's effective, if wrong password is input, parameter setting interface cannot be entered, so the password cannot be checked or changed. Please remember the password clearly, if it's set wrongly or forgot, contact the manufacturer.

FP-01	Parameter initialization		Factory default	0
	Setting range	0	No operation	
		1	Recover factory default	
		2	Clear fault record	

1: The inverter will recover factory default.

2: The inverter will clear latest fault records.

FP-02	User setting inspection		Factory default	0
	Setting range	0	Ineffective	
		1	Effective	

When FP-02 function is chosen, LED only displays the parameters that are different from factory default, which make it convenient for users to check the setting and find problems.



Application and Adjustment

Chapter 7 Application and adjustment

This chapter introduces the application ways of ME320L(N) inverter, and also typical working conditions such as power failure emergency running, detection running and so on.

7.1 Multi-stage speed control mode

Multi-stage speed control mode is a common mode in elevator application, whose characteristic is strong anti-jamming ability, good suitability and easy to be realized. But in typical multi-stage speed control when different speed combinations are switched, the acceleration and deceleration curves are the same, and they affects each other, so users can not attend everything during actual adjustment. ME320L(N) inverter has been specially designed to solve this problem: each speed combination corresponds to different acceleration and deceleration curve, which make adjustment easier for users.

7.1.1 Wiring of multi-stage speed control system

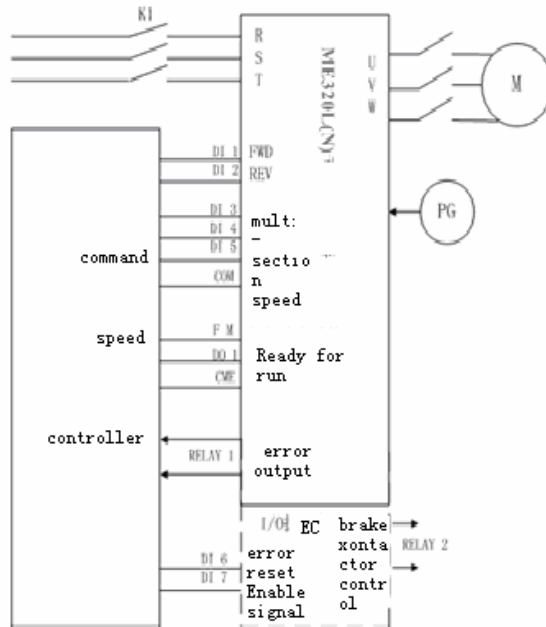

Fig 7-1 wiring of multi-stage control

7.1.2 Parameter setting

This part is to adjust parameters of the most typical use (Fig 7-1 (without expansion card)) in 3 times: motor tuning, inspection running, high speed operation. If more input and output are needed, for example, enable function, they can be realized through expansion card.

1、 Adjustment of inverter for asynchronous motor

1) Process

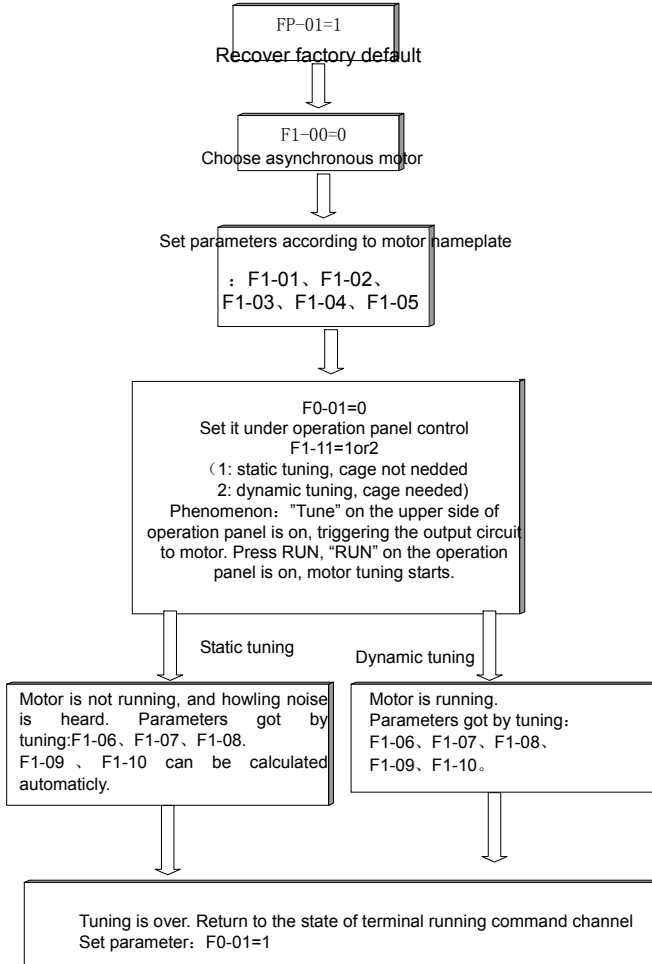

Fig 7-2

2) Inspection running

Before inspection running, the following should be set:

A. If it's close-loop running, set FA-00 to corresponding pulse. If it's open-loop running, set F0-00=0.

B. Corresponding frequency of inspection speed stage combination. (set one of F6-00~F6-07 according to the speed stage combination applied by the system. Suppose it as F6-0N);

C. Corresponding curve of inspection running (set F6-M, M=N+8, setting range is 1~4);

D. Acceleration and deceleration time of inspection running (set the time according the chosen curve. The value is determined by the speed of the elevator) .

Instruction: If the inverter wiring has expansion card, or the terminal function is not the same with the principle diagram, please set corresponding parameters in F4、F5 groups.

3) High speed operation

In order to ensure the comfortability of elevator, parameters of inverter should be set:

A. Please make sure the inverter and encoder have been well connected, the setting of FA-00 PG pulse is correct, and F0-00=1, SVC.

B. Set all the corresponding frequency value of speed stage combinations.

C. Set corresponding curve of each frequency. (It's suggested that curve 1 is used for gigh speed operation, and the lowest speed if the high speed has several speeds.)

D. Set acceleration and deceleration time, start segment time and end segment time of each curve according to the comfortability.

E. Adjust parameters of F2 and F3 groups according to running, startup and stop comfortability.

4) Examples of application

The following is the final setting of parameters of the 1m/s elevator, speed stage combination of which is multi-stage speed 2 is inspection speed, 3 is creeping speed, 7 is high speed.

(Only those different from factory default are listed, and motor parameters not included):

Function code	Name	Setting	Function code	Name	Setting	Function code	Name	Setting
F6-02	Multi-stage speed 2	10	F6-10	Multi-stage speed 2 acceleration and deceleration time selection	4	F7-12	Acceleration time 4	1.8
						F7-13	Deceleration time 4	0.6
F6-03	Multi-stage speed 3	3	F6-11	Multi-stage speed 3 acceleration and deceleration time selection	3	F7-08	Acceleration time 3	0
						F7-09	Deceleration time 3	20
F6-07	Multi-stage speed 7	48	F6-15	Multi-stage speed 7 acceleration and deceleration	1	F7-00	Acceleration time 1	3.6
						F7-01	Deceleration time 1	4.2
						F7-02	S curve 1 start	40

Function code	Name	Setting	Function code	Name	Setting	Function code	Name	Setting
				time selection			segment time	
			F6-16	Inspection speed selection	2	F7-03	S curve 1 end segment time	40

2、IP model adjustment

1) Tuning of synchronous motor

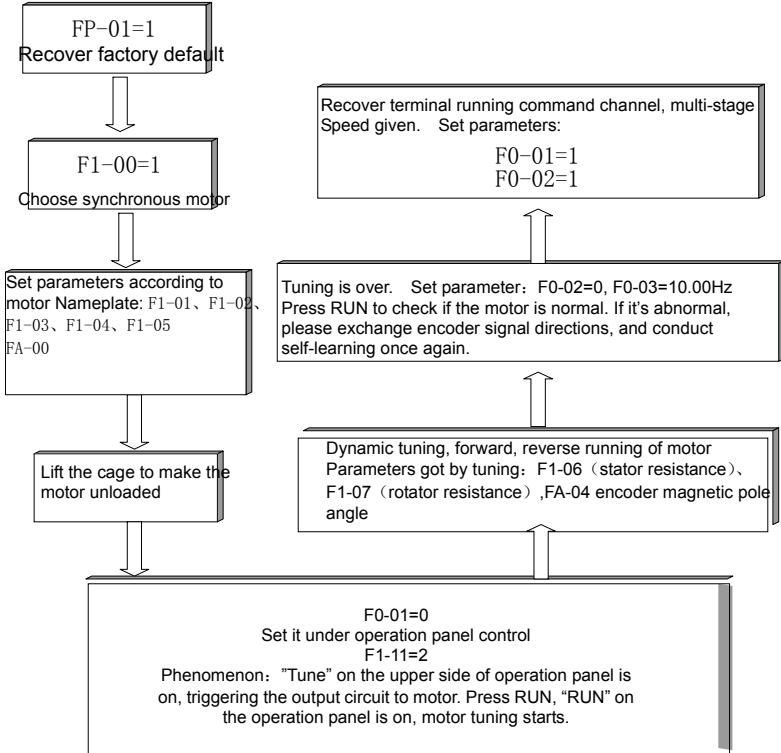

Fig 7-3

2) Encoder Angle Identification function without releasing the load

A、 Method

In order to make the use of synchronous motor in the scene convenient, ME320L (N) inverter was designed with the method to identify the encoder angle without releasing the load. In this way, users can identify the encoder angle without taking down the wire rope of the elevator. Steps are as follows:

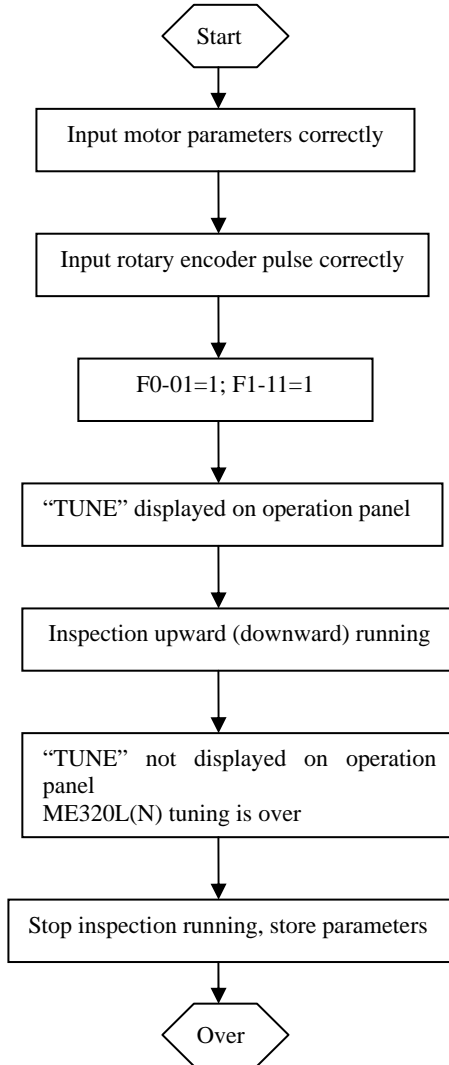

Fig 7-4

B 、 Notes:

- a) As there's no current output when ME320L(N) stores parameters after tuning, so in this situation, control system of the elevator connect ME320L(N) brake function into the brake circuit of the system to avoid elevator sliding.

- b) When tuning is over, there will be 5 seconds for ME320L(N) to store parameters, during this time ME320L(N) will not respond to the input command.
- c) Encoder angle identification function without releasing the load of ME320L(N) must be performed by qualified engineers, otherwise, it's dangerous!
- d) Cancel the function software applying weighingless pre-torque compensation before starting tuning to avoid abnormality.
- e) If tuning cannot be done normally, exchange any two of the power wires UVW of the inverter.

3) Inspection running

Before inspection running, the following should be set:

- A. Before running please make sure the encoder and inverter output are connected to U、V、W phase of the motor, and the order is not changed after motor self-learning.
- B. Corresponding frequency of inspection speed combination (set one of the parameters F6-00~ F6-07 according to the speed combination applied by the system, suppose it as F6-0N);
- C. Corresponding curve of inspection running (set F6-M, M=N+8, setting range is 1~4);
- D. Acceleration and deceleration time of inspection running (set according to chosen curve. The value is decided by the speed of elevator) .

Instruction: If the inverter wiring applies expansion card or the terminal used is not the same with the principle diagram, please set corresponding parameters in F4、F5 groups.

4) High speed operation

In order to ensure the comfortability of elevator, parameters of inverter should be set:

- A. Before running please make sure the encoder and inverter output are connected to U、V、W phase of the motor, and the order is not changed after motor self-learning.
- B. Set all the corresponding frequency value of speed stage combinations.
- C. Set corresponding curve of each frequency. (It's suggested that curve 1 is used for high speed operation, and the lowest speed if the high speed has several speeds.)
- D. Set acceleration and deceleration time, start segment time and end segment time of each curve according to the comfortability.
- E. Adjust parameters of F2 and F3 groups according to running, startup and stop comfortability.

5 Examples of application

The following is the final setting of parameters of the 1m/s elevator, speed stage combination of which is multi-stage speed 2 is inspection speed, 3 is creeping speed, 7 is high speed.

(Only those different from factory default are listed, and motor parameters not included):

Function code	Name	Setting	Function code	Name	Setting	Function code	Name	Setting
F6-02	Multi-stage speed 2	10	F6-10	Multi-stage speed 2 acceleration	4	F7-12	Acceleration time 4	Acceleration and deceleration
						F7-13	Deceleration	

Function code	Name	Setting	Function code	Name	Setting	Function code	Name	Setting
				and deceleration time selection			time 4	on time of synchronous motor are related to the rated speed of the elevator and the rated frequency of the motor.
F6-03	Multi-stage speed 3	3	F6-11	Multi-stage speed 3 acceleration and deceleration time selection	3	F7-08	Acceleration time 3	
						F7-09	Deceleration time 3	
F6-07	Multi-stage speed 7	48	F6-15	Multi-stage speed 7 acceleration and deceleration time selection	1	F7-00	Acceleration time 1	
						F7-01	Deceleration time 1	
						F7-02	S curve 1 start segment time	
			F6-16	Inspection speed selection	2	F7-03	S curve 1 end segment time	

Note: Emergency leveling function of synchronous motor refers to Chapter7.4.

7.2 Analogue control mode

ME320L(N) inverter has another commonly used mode: analogue speed given mode. In this mode, reference speed applies analog input, running command applies terminal input. The following is the simple introduction of this mode.

7.2.1 Wiring of analogue control system

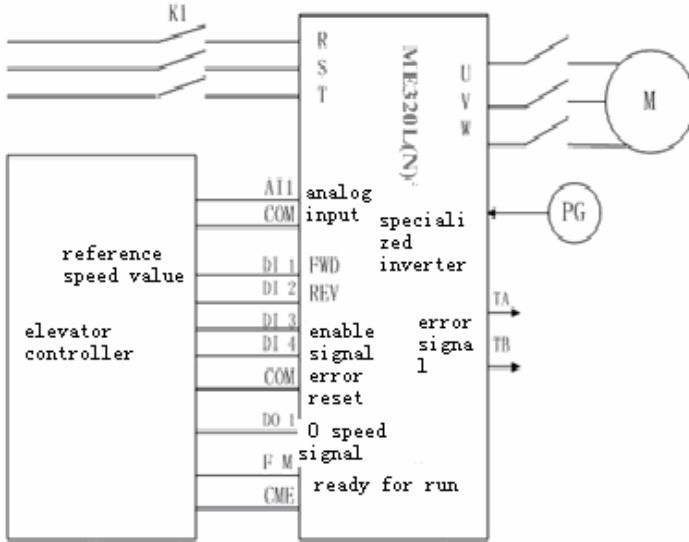

Fig 7-5

7.2.2 Parameter setting

In analogue control system, as an executor, the inverter follows the commands of the controller fully, like the using in the upper picture, and suppose analogue input signal is 0~+10V, parameters needed to be adjusted are as follows:

	Function code	Name	Setting value	Function code	Name	Setting value
Analog function parameters	F0-02	Speed selection	2	F6-18	Analog minimum input	0
	F6-19	Corresponding setting of analog minimum input	0	F6-20	Analog maximum input	10
	F6-21	Corresponding setting of	100	F8-22	Analog input	0.1

		analog maximum input			filtering time	
Motor encoder parameters	F1 Group, FA Group	Got by motor self-learning, refer to motor tuning of synchronous asynchronous motor under multi-stage speedcontrol.				
Vector control speed loop parameters	F2 Group	Adjust according to actual running characteristics.				
Input output terminal Defining parameters F4 、 F5 Group	F4-03	DI3 terminal function selection	7	F4-04	DI4 terminal function selection	6

7.3 Inspection running

ME320L(N) inverter has internal inspection running mode when it's under multi-stage speed control mode, which has been designed according to the characteristics of the elevator inspection running. The following is the simple introduction of the control process and running curve.

7.3.1 Wiring of the system

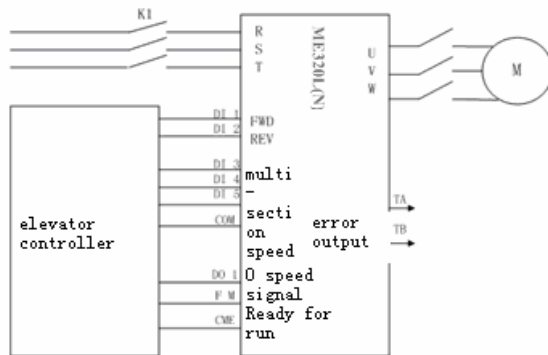

Fig 7-6

7.3.2 Parameter setting and running curve

As a special working condition, inspection running has strict national standard. Its running curve is strangely different that of high speed running.

When ME320L(N) inverter is under multi-stage speed control, if inspection input is effective, inspection running speed will be decided by the setting of F6-16. For example, F6-16=3, if the elevator is given forward (reverse) running command, and there's also inspection input terminal signal, ME320L(N) will run at the target frequency of multi-stage speed 3, and acceleration time is decided by the corresponding time curve of multi-stage speed 3. During stall, if inspection input signal is cancelled first, the system will decelerate to 0 during the deceleration time of multi-stage speed 3 until forward or reverse running command is cancelled. (As in the following figure, deceleration time can be set very short, for example, 1s, in this way, quick stall can be ensured) .

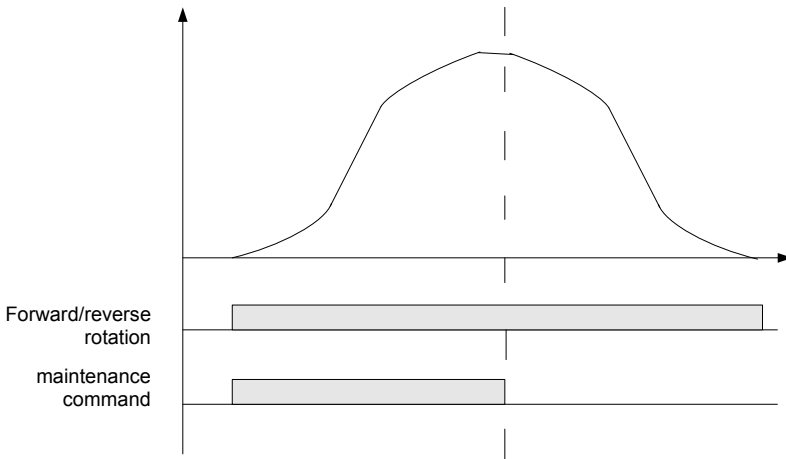

Fig 7-7

If forward or reverse running command is cancelled directly during inspection running, ME320L(N) will stop output immediately, as shown in the following figure.

V

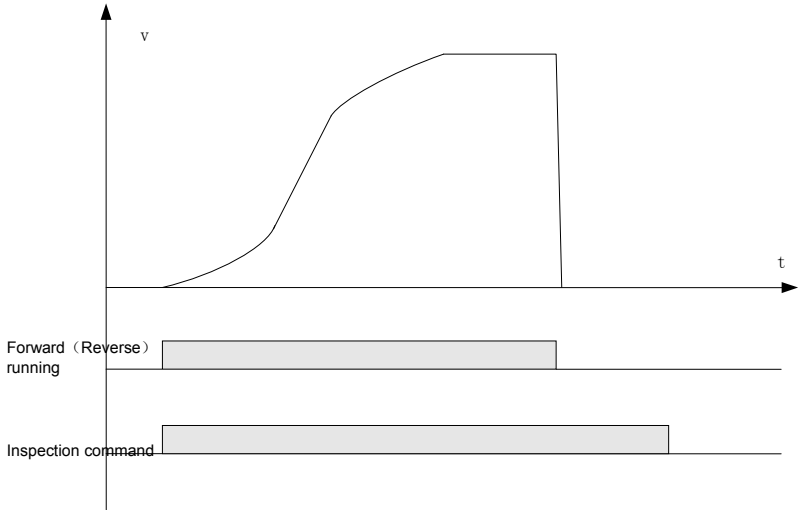

Fig 7-8

Suppose the speed of a certain elevator is 1m/s, inspection running applies multi-stage speed 5, whose acceleration and deceleration time is acceleration and deceleration time 4, then inspection running speed parameters setting is as follows:

Function code	Name	Setting	Default	Remark
F6-05	Multi-stage speed 5	10.00Hz	0.00Hz	Rated motor speed is 50.00Hz
F6-13	Multi-stage speed 5 acceleration and deceleration time selection	4	1	
F6-16	Inspection speed selection	2	0	Inspection speed choose multi-stage speed 2
F7-12	Acceleration time 4	2.0s	20.0s	
F7-13	Deceleration time 4	1.0s	20.0s	Setting value should be small enough to ensure that the brake can decelerate to the least before closing up.

7.4 Power failure emergency running

In the using of elevator, if the power is cut suddenly, passengers may be kept in the cage.

ME320L(N) applies two kinds of power failure running modes: running powered by UPS and running powered by 48V battery.

Running powered by 48V battery: The main circuit of ME320L(N) is powered by 48V battery, while the other parts of the elevator are powered by UPS (more than 220V) (or inverter power) . In this way, the volume of working power can be very small.

Running powered by UPS: Both the main circuit of ME320L(N) and the working are powered by UPS.

The following is the explanation taking the running powered by 48V battery as example:

7.4.1 Wiring of power failure emergency running (Powered by 48V battery)

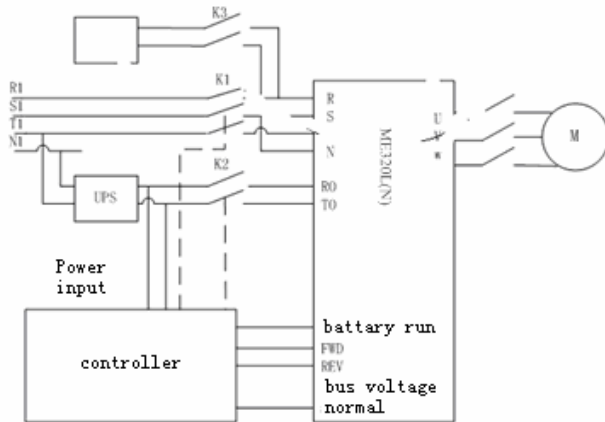

Fig 7-9

7.4.2 Running order

When ME320L(N) is in multi-stage speed combination mode, the wiring should conform to the upper figure, in which DO1 is the terminal for normal output of bus. Multi-stage speed 2 is emergency running speed combination. So the following function codes should be set:

Function code	Name	Setting	Default	Remark
F5-01	DO1 output selection	8	3	Bus undervoltage
F6-02	Multi-stage speed 2	2.00Hz	0.00Hz	Rated motor speed is 50.00Hz
F6-10	Multi-stage speed 2 acceleration and deceleration time selection	3	1	

Function code	Name	Setting	Default	Remark
F7-08	Acceleration time 3	30.0s	20.0s	Increase acceleration time to avoid too large impact current

Taking upward running as example, running order is as follows:



Fig 7-10

In them, battery running signal is given out by controller, and it's connected to ME320(N) through terminal DI, in this way it can tell if current running is powered by battery. Contactors K1、K2、K3 are controlled by controller.

7.4.3 Notes:

- Reasonably set battery running speed, acceleration and deceleration time according to the actual condition of the elevator. It is suggested that acceleration and deceleration time are more than 10s. Battery running speed should be set according to the following formula:

$$\text{Battery running speed} < (48V-5V) * \text{Motor rated frequency} / (1.414 * \text{Rated voltage})$$
- Battery inputs 48V DC voltage to the main circuit; working power is input by UPS and other auxiliary power supplies.
- Stable output current of battery is suggested to be larger than no-load current of tractor.
- ME320L(N) identify if it is battery running through terminal (DI) ; at this time, running speed of ME320L(N) is given by multi-stage speed, whose acceleration and deceleration time correspond to those of battery; what is different from normal running is that in battery running curve acceleration and deceleration turn into straight.

- 5) In battery running ME320L(N) inverter does not conduct DC bus voltage inspection, as a result, before the brake is opened, it must be made sure that 48V voltage has been input into the main circuit.
- 6) In battery running ME320L(N) will control the speed, if the speed is more than 8Hz, fault protection (E032) will be performed.
- 7) In battery running load running should be avoided, so external controller should balance load or brake the running direction of the load.
- 8) In the process of power failure emergency running, please pay attention to the working order of the contactor of the main power connected to inverter and the contactor of UPS, they cannot be closed up at the same time, or it will result in the damage of UPS and battery.

7.5 Analogue weighing adjustment

In the running of ME320L(N), FWD (forward running) corresponds to upward running of the elevator, while REV (reverse running) to downward. The following analog weighing adjustment method is discussed on the basis of this.

7.5.1 Parameter setting method

Suppose AI1 is pre-torque input channel, then F3-09=2; F3-10=elevator balance factor. When the cage is no-load, sampling value of AI1 can be checked by switching the parameters on the operation board and input to F3-18, in the same way, when the cage is full-load, input the sampling value of AI1 to F3-19. These two parameters can also be identified by weighing self-learning.

Finally, adjust F3-11 to choose proper compensation, usually, it is around 0.6.

7.5.2 Adjustment method of balance factor

In the scene sometimes when the no-load compensation is correct, the effect of load increasing in the cage will deviate. The cause is that the balance factor is not accurate.

In the situation of unknown balance factor, balance factor and F3-11 (gain) can be identified through no-load and full-load compensation, which will bring the same system compensation effect.

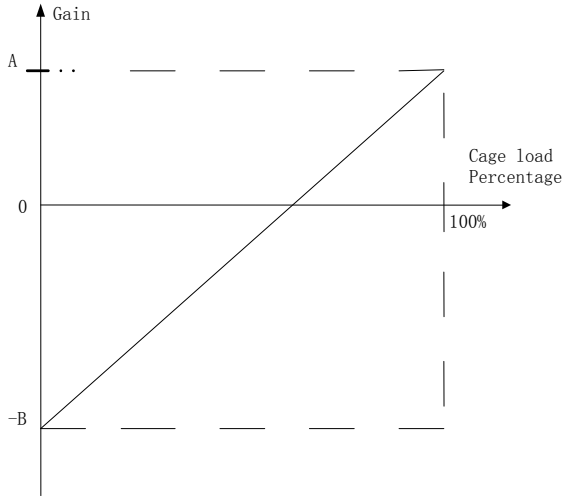

Fig 7-11

As in the upper figure, set F3-10 to 50% first, do no-load self-learning when the cage is no-load, then adjust F3-11 in the process of upward and downward running. Observe if motor sliding happens in the moment of opening the brake. When motor torque compensation makes there's no sliding or over-torque compensation, record $F3-11=B$; then load the cage fully, conduct full-load self-learning and adjust F3-11 in the process of upward and downward running, in the same way, if the compensation is just correct, $F3-11=A$.

In the figure, the oblique line is the correct compensation curve of the elevator, its intersection point with the abscissa axis is balance compensation point of the elevator. The following can be calculated :

$$F3-10=100*B/ (A+B); \quad F3-11= (A+B) /2;$$

For example, in no-load testing $B=0.7$ is got and $A=0.4$ is got in full-load testing, so corresponding balance factor is $F3-10=36.4\%$, $F3-11=0.55$.

7.5.3 Adjusting method of contrary running

If it is set in the scene that FWD (forward running) corresponds to upward running of the elevator, while REV (reverse running) to downward, instead of improving, the above method will deteriorate the compensation. The cause is that the compensation is in a contrary direction. In this situation, record cage no-load and full-load sampling value F3-18、F3-19 and balance factor F3-10. For example: $F3-18=X$; $F3-19=Y$; $F3-10=Z$; then, $F3-19=X$; $F3-18=Y$; $F3-10=100-Z$.

7.6 Weighingless adjustment method

7.6.1 Basic parameter setting

Explanation	Parameter	Setting
Encoder type selection	F1-00	0
Weighing mode selection	F3-09	5
Brake open time (Zero-speed hold time)	F3-04	More than 0.5s

7.6.2 Basic parameter setting

Increase the value of zero-servo current factor (FD-05) regularly until sliding is small enough after brake is open and the motor has no ascillation.

Adjustment program can observe the sliding of zero-servo through the version number (F8-06) , in which 100 refer to sliding distance is one dental. Usually it is OK if the sliding is within one dental when the load is one person.

In the situation that zero-servo speed loop TI(FD-07)is smaller than 1.00, the motor will have obvious ascillation, please increase the value of zero-servo current factor (FD-05) .

Zero-servo speed loop KP(FD-06) can be kept almost unchanged, do not set it too large, or it will result in ascillation of the motor.

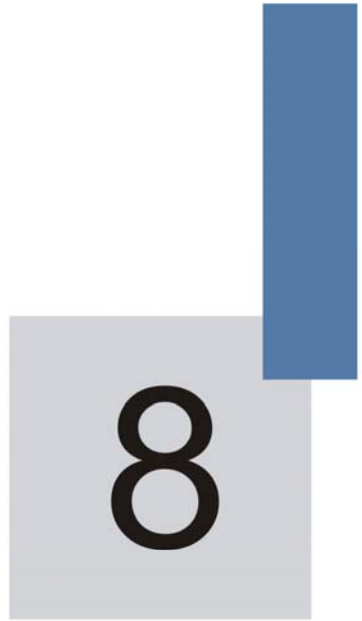

Faults – Causes - Remedies

Chapter 8 Faults-Causes-Remedies

8.1 Fault alarm and remedies

ME320L(N) inverter has 40 pieces of alarm information and protection functions. When fault happens, protection function will react, and the inverter will stop output, then fault relay contactor will react, which will display the fault code on the panel. Before asking for service, users can conduct testing themselves according to the tips in this chapter to find out the causes and disposals. If there are still any questions, please ask the agent or our company for service.

【Note】 Err33、 Err16、 Err17 can not be reset. Must reset when power is off.

8.2 Common faults and remedies

Operation panel display	Description	Possible causes	Remedy
Err01	Inverter unit protection	1.Main circuit output is grounded or short wired; 2.The connection of traction machine is too long; 3.Work condition is too hot; 4.The connections inside the inverter become loose;	1.Obviate exterior problems such as connection; 2.Add reactor or output filter; 3.Inspect the wind channel and fan; 4.Please contact with agent or factory;
Err02	Acceleration over-current	1.Main circuit output is grounded or short wired; 2. If the motor has done parameter tuning; 3. Load is too heavy;	1.Obviate exterior problems such as connection; 2.Tune motor parameters; 3,Lighten suddenly added load;
Err03	Deceleration over-current	1.Main circuit output is grounded or short wired; 2.If the motor has done parameter tuning; 3.Load is too heavy; 4. Deceleration curve is too steep;	1.Obviate exterior problems such as connection; 2.Tune motor parameters; 3,Lighten suddenly added load; 4.Adjust curve parameters;
Err04	Constant speed over-current	1.Main circuit output is grounded or short wired; 2.If the motor has done parameter tuning;	1.Obviate exterior problems such as connection; 2.Tune motor parameters;

Operation panel display	Description	Possible causes	Remedy
		3.Load is too heavy; 4.Pulse wheel encoder interference is too strong;	3.Lighten suddenly added load; 4.Select proper encoder, and adopt shielded cable;
Err05	Acceleration over-voltage	1.Input voltage is too high; 2.Elevator inverse pull is serious; 3.Brake resistance is too large, or brake unit is abnormal; 4.Acceleration curve is too steep;	1.Adjust input voltage; 2.Adjust the elevator startup time sequence; 3.Select proper brake resistance; 4.Adjust curve parameter;
Err06	Deceleration Over-voltage	1.Input voltage is too high; 2.Brake resistance is too large, or brake unit is abnormal; 3.Deceleration curve is too steep;	1.Adjust input voltage; 2.Select proper brake resistance; 3.Adjust curve parameter;
Err07	Constant speed over-voltage	1.Input voltage is too high; 2.Brake resistance is too large, or brake unit is abnormal;	1.Adjust input voltage; 2.Select proper brake resistance;
Err08	Control power fault	1.Input voltage is too high; 2.Drive control panel is abnormal;	1.Adjust input voltage; 2.Please contact with agent or factory;
Err09	Undervoltage fault	1.Transient power cut exists; 2.Input voltage is too low; 3.Drive control panel is abnormal;	1.Obviate exterior problem of power; 2.Please contact with agent or factory;
Err10	Inverter overloaded	1.Brake circuit is abnormal; 2.Load is too heavy;	1.Inspect brake loop and power supply; 1.Lighten load;
Err11	Motor overloaded	1.F9-01 setting is unsuitable; 2.Brake loop is abnormal; 3.Load is too heavy;	1.Adjust parameter; 2.Inspect brake loop and power supply;
Err12	Input phase-failure protection	1.Input power asymmetry; 2.Diver control panel is abnormal;	1.Adjust input power; 2.Please contact with agent or factory
Err13	Output phase-failure protection	1.The connections of main circuit output become loose; 2.Motor is broken;	1.Inspect connection; 2.Obviate motor fault;

Operation panel display	Description	Possible causes	Remedy
Err14	Radiator overheated	1.Environmental temperature is too high; 2.The fan is broken; 3.The wind channel is blocked;	1.Reduce the environmental temperature; 2.Clear the wind channel; 3.Change the fan;
Err15	External fault	Controller ha faults.	Test if the cotroller is normal.
Err16	Communication fault	In stop state, the encoder has fault.	In stop state, in constant 50ms, deviation between the angle calculated by encoder CD signal and the actual angle is too big. If AB signal is right, then it can be thought that CD signal is seriously interfered.
Err17	Encoder fault	Fault happens to encoder in running	In running, the constant 3 times when encoder Z signal arrives,deviation between the angle calculated through AB signal and expected reset angle is too big. If CD signal on absolute position is right, maybe Z signal has been interfered.
Err18	Current inspection fault	Drive control panel is abnormal;	Please contact with agent or factory;
Err19	Motor tuning fault	1.Motor parameter setting is incorrect; 2.Parameter tuning is overtime;	1.Input the right motor parameter; 2.Detect motor lead wire;
Err20	Pulse wheel encoder fault	1.Pulse wheel encoder model is suited or not; 2.Connection error;	1.Choose push-pull or open-collector pulse wheel encoder; 2.Obviate connection problem;

Operation panel display	Description	Possible causes	Remedy
Err21	Rotary encoder fault		
Err22	Reserved		
Err23	Short circuit to ground protection	Output short to ground.	Detect if motor or contactor in output side is short to ground. Please contact with agent or factory;
Err25	Data storage fault		
Err32	Battery overspeed running	Battery speed in running is more than 8Hz	Check if the voltage of battery is normal; Check if the wiring is loose;
Err33	Overspeed fault	Inverter running speed is beyond overspeed judgment level, and cumulative time is more than overspeed judgment time.	1.Check if the power of motor is applicable; 2.Check if elevator is overloaded; 3.Check if rotary encoder signal is right;
Err36	Contactors fault	Before the brake is opened, motor current is 0; During running contactor feedback signal disappear for more than 1s; When contactor is closed up. There is no feedback signal;	1.check if the contacts of contactor and feedback contact is normal; 2.Check if the connection of U、V、W of the controller is normal; 3.Check if the control circuit power of the contactor is normal;
Err37	Brake fault	Brake output is different from the feedback signal for more than 2s	1.Check if brake coil and feedback contact is normal; 2.Make clear the signal features of feedback contact (normal open, normal closed); 3.Check if the control circuit power of brake coil is normal;

Operation panel display	Description	Possible causes	Remedy
Err38	Contact conglutination	During stall feedback signal of brake and running contactor is effective for more than constant 2s	Check the wiring; Check brake and running contactor.
Err39	Motor overheated	Relay input is effective when motor is overheated	1.Check if the motor id=s correctly used; 2.Improve the cooling condition of the motor.
Err40	Elevator running conditions not conformed to	Elevator running setting time is up	1.Elevator is too slow or the height of the building is too big. 2.Elevator has been usedfor a long time, and it needs maintenance;
Err55	DSP communication protection	Wire connection drive panel and control panel is abnormal	Check the wire between drive panel and logic panel

