

Foreword

NICE2000 is a modularized and high-powered elevator integrative controller, which is developed independently by Suzhou Monarch control technology Co., Ltd. It represents the future development trend and can satisfy the variety needs of different factories. Compared with the traditional general-type controller, it has compact structure, more convenient installation method. What is prior, its advanced motor control arithmetic, motor parameter auto-tuning (static tune and complete tune), run contactor control, brake contactor control, bypass variable frequency energy saved control, complete variable frequency energy saved control, speed track control are incomparable. Particular functions like run contactor contact detection, brake contactor contact detection, touch conglutination detection, up and down light- electricity signal, left and right armrest signal, step loss detection provide the most dependable guarantee for the safe movement of the elevator.

Moreover , the special single-key design of NICE2000 elevator control system makes the complicated keyboard operation much more easier; it can use the general terminal RJ45 to connect to any position of the operation panel, that enables the adjust of the elevator convenient and simple.

Main features:

- Integration
- ☞ Perfect combination of drive and control

NICE2000 elevator control system, gathering all functions of motor driving part and control logic part in the whole, highly integrates the elevator control system, which come to a compact structure, and avoid the tedious process of choosing the logic control part and drive part respectively. It accomplishes the difficult task with much lower cost and better match which originally can only achieved by two divided parts. NICE2000 not only reduces periphery connection to a large extent, but also reinforces the safety and the stability of the elevator.

- ☞ Dispense with PLC and elevator control board

NICE2000 control system, integrates the motor control and elevator control, replaces the traditional PLC or the “elevator control board + inverter” control mode. It save the PLC or elevator control board so that save the electric costs, on the basis of the reliability improvement of control system.

- ☞ Adapt to global variable standards

With many years professional experience in elevator control system, NICE2000 has considered the different standards in different countries. It meets the requirement of EN115 (Europe standard), AS1735 (Aussie standard), A17.1 (America standard), PUBEE (Russia standard), K (Korea standard), Hongkong and Singapore's special requirements.

- Bypass invert frequency
- ☞ Dispense with braking resistance

NICE2000 elevator control system has original bypass variable frequency of the integrated control technology, taking full advantage of operation, and making conversion elevator control operate without braking resistance.

- ☞ Invert frequency work frequency redundancy design

NICE2000 elevator control system has complete variable frequency control, bypass variable frequency control, Y- Δ control etc. multi-control modes, and inside placed abundant elevator control function, and utmost satisfy the usage need of different customers, reduce fault stop rate, also provide more flexible choice to customer.

- ☞ Energy saving usage

When the elevator is in the state of standby and speedup, it uses frequency-conversion control; while in stable operation, it adopts frequency control. This kind of intermittent working can surely save energy.

- Professional quality
- ☞ Specialized manufacture platform

The manufacturing platform of the NICE2000 adopts specialized streamline. It adopts the standardized work specification, perfect management system, advanced control and strict product examination system in the production line.

- ☞ Independent wind channel design three defend processing

The internal PCBs of NICE2000 all introduce three-defend painting craft, and the whole series adopt the independent wind channel design, raising the stability of NICE2000 circulate over long-term in the elevator, automatic sidewalk in different application circumstance

- ☞ Meet EMC standard

It has advanced lightning-proof design inside, which raises the credibility of the

system consumedly. Moreover, NICE2000 elevator control system has super strong anti-interference ability, meet the harsh EMC standard.

Please read this manual carefully before you use the NICE2000 elevator control system.

The contents of the manual has already confirm before sending to press. But our company is making every effort to the continuously perfection and improvement of the production, so we the reserve the rights of modifying product specification, function and other contents of this manual. If there is any change, we won't give prior notice.

Suzhou Monarch Control Technology Co., Ltd provides all-directions technical support for the customers. If there is any question, please contact with Monarch product sale center or the customer service center.

Thank you for your consistent support to us!

Contents

Foreword	I
Chapter 1 Safety and Precautions	- 2 -
1.1 Safety information	- 2 -
1.2 Cautions	- 5 -
Chapter 2 Product Information	- 10 -
2.1 Name designation rules	- 10 -
2.2 Nameplate	- 10 -
2.3 Controller models.....	- 11 -
2.4 Technical Specification.....	- 11 -
2.5 Product appearance and installation holes dimension	- 12 -
2.6 option units	- 14 -
2.7 Daily maintenance of controller.....	- 15 -
Chapter 3 Installation and Wiring	- 18 -
3.1 Mechanical installation.....	- 18 -
3.2 Electric part installation.	- 20 -
3.3 The solution for EMC problem	- 30 -
Chapter 4 Operation and Test-run of controller	- 34 -
4.1 technical terms of NICE2000 controller.....	- 34 -
4.2 Introduction of operation and display panel	- 35 -
4.3 Function code examine & operation instruction	- 36 -
4.4 Operation mode of shortcut menu	- 38 -
4.5 Password setting	- 40 -
Chapter 5 Function parameter Table	- 44 -
5.1 Instruction of function parameters.....	- 44 -
5.2 Function parameter table	- 44 -
Chapter 6 Instruction of function parameter	- 64 -
6.1 F0 Group Basic parameter	- 64 -
6.2 F1 Group Motor parameter	- 66 -
6.3 F2 Group Vector control parameter	- 67 -
6.4 F3 Group Motor control parameter	- 69 -

6.5	F4 Group	Input function parameter	- 71 -
6.6	F5 Group	Output function parameter	- 78 -
6.7	F6 Group	Elevator basic parameters.....	- 81 -
6.8	F7 Group	Assistant function parameter.....	- 84 -
6.9	F9 Group	Assitant management parameter.....	- 88 -
6.10	F9 Group	Protection function parameter	- 89 -
6.11	FA Group	Communication parameter	- 93 -
6.12	FB Group	Elevator special function setting.....	- 94 -
6.13	FC group	Additional function parameters.....	- 102 -
6.14	FF Group	Factory parameter (reserved).....	- 104 -
6.15	FP Group	User parameter	- 104 -
	Chapter 7	Typical application and adjusting of system	- 108 -
7.1		Typical application of bypass variable frequency	- 108 -
7.2		Typical application of complete variable frequency.....	- 112 -
7.3		Adjusting procedures	- 114 -
	Chapter 8	Fault Diagnosis and Countermeasures	- 120 -
8.1		Fault information and solutions	- 120 -
8.2		Common faults and disposal.....	- 124 -

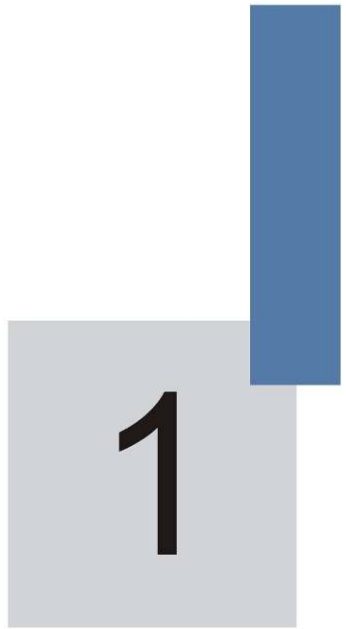

Safety and Precautions

Chapter 1 Safety and Precautions

Safety definition:

There are two kinds of safety tips:



Failure to follow these instructions will result in death or serious injury.



Failure to follow these instructions will result in medium hurt and equipment damage.

1.1 Safety information

1.1.1 before installation



- Do not use the controller that is damaged or has defect. Otherwise, it may cause danger!

1.1.2 when installation



- Please install on objects which are not combustible (such as metal) and keep away from combustible substances. Otherwise it may cause fire!

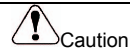

- Do not leave wiring terminal or screw in the controller. Otherwise it will cause damage to controller.
- Install the controller at the place where there is less vibration, and avoid strong sunshine.

1.1.3 during wiring



- Only the qualified electrical engineer can perform the wiring. Otherwise there will be unexpected danger.

**Danger**

- A circuit breaker must be installed between the electric power and the controller. Otherwise there will be danger of fire.
- Wiring can only be done after the electric power is cut off. Otherwise there will be danger of electric shock.
- Please connect the controller to the ground according to the standard. Otherwise it may cause an electric shock.
- Do not connect the input terminals with the output terminals (U, V, W). Otherwise the controller may be damaged.
- Ensure the wiring meet the EMC requirements and the slow safety standard. Please refer to the as to the wire size. Otherwise accident may occur!

1.1.4 Before power-on**Caution**

- Please confirm the mains voltage level is consistent with that of the controller and the input (R, S, T) and output (U, V, W) wiring are correct, and check if there is any short circuit in peripheral circuit and if the wiring is fixed firmly. Otherwise the controller may be damaged!
- Every part of the controller had passed the dielectric strength test at factory. Please do not do this test again by yourself. Otherwise accident may occur!

**Danger**

- Please mount the cover plate properly before power-on the controller. Otherwise accident may occur!
- All of the wiring should comply with the instructions of the manual and make sure connect the circuitry correctly. Otherwise accident may occur!

1.1.5 After power-on**Danger**

- Do not open the cover of the controller after power-on. Otherwise there will be danger of electric shock!
- Do not touch the controller and its circuit with wet hands. Otherwise there will be danger of electric shock!
- Do not touch the controller terminals. Otherwise there will be danger of

**Danger**

electric shock!

- At power-on, the controller will perform the security check of the external heavy-current circuit. Do not touch U,V,W terminal or motor connection terminal, otherwise there will be danger of electric shock!

**Caution**

- If parameter identification is required, please pay attention to the possible injury that may occur due to the rotating motor!
- Please do not change the factory settings; otherwise the equipment may be damaged!

1.1.6 When running

**Danger**

- Do not touch the fan and the discharging resistor to check the temperature, otherwise you may get burned!
- Do not let unskilled technician check signal in a running controller. Otherwise there will be danger of injury or damaging the equipment.

**Caution**

- Do not leave objects into a running controller; otherwise the controller may be damaged!
- Do not start and stop the controller by on/off of electric power, otherwise the controller may be damaged!

1.1.7 When maintenance

**Danger**

- Do not repair or maintain the controller with power on, otherwise there will be danger of electric shock!
- Please repair or maintain the controller after confirming the charge LED turns off. Otherwise there may be human injury caused by the residual charge of the capacitor!
- Only qualified electrical engineer can repair or maintain the controller, otherwise there will be danger of human injury or damaging the equipment.

1.2 Cautions

1.2.1 Check the insulation of the motor

When the motor is used for the first time, or reused after storing for a long time, or in regular checkup, the user must check the insulation of the motor to prevent the poor insulation of the windings of motor from damaging the controller. The motor connection must be divided from the controller during the insulation check. It is recommended to use a 500V Mega-Ohm-Meter to check and the insulation resistance shall not be less than 5M Ω .

1.2.2 Thermal protection of motor

If the rated capacity of the motor selected is not matching that of the controller, especially when the rated power of the controller is bigger than that of the motor, make sure to adjust the parameters for motor protection inside the controller or to install a thermal relay to the motor to guarantee the protection to the motor.

1.2.3 Run above work frequency

Please don't use it above work frequency. If user sets the frequency above 50Hz running, please take the equipment intensity and duration into your account.

1.2.4 Motor heat and noise

Since the output voltage of the controller is in PWM wave with some harmonics, the temperature may raise, the noise and vibration may slightly increase compared with the controller running at main frequency.

1.2.5 Pressure-sensitive device or capacitor at output side

Since the controller outputs PWM wave, the capacitor (used for improving power) and pressure-sensitive resistor (used for lightening-proof) shouldn't be installed at the output side of the controller, otherwise the controller may have transient over-current and may be damaged.

1.2.6 Switches Used at the Input and Output terminal of the Controller

If the contactor is required to be installed between the controller and the power supply, it is prohibited to start or stop the controller with this contactor. Frequent charge and discharge will shorten the life of capacitor in the controller. If the switches (such as contactors) are connected between the output terminal and the motor, make sure to start and stop the controller when the controller

has no output, otherwise the modules in the controller may be damaged.

1.2.7 Usage beyond the range of rated voltage

NICE2000 controller shall not be used out of the specified range of operation voltage. Otherwise the internal components of the controller may be damaged. If needed, please use corresponding voltage regulation device to change the voltage.

1.2.8 Change three-phase input to two-phase input

Do not change NICE2000 control system three phase to two phase. Otherwise there will be malfunction or controller damaged.

1.2.9 Lightning proof

There are lightning-proof devices inside the controller and can protect itself from some inductive thunders, but the user should install other lightning protection device at the front of the controller if lightning strike occurs frequently.

1.2.10 Altitude and de-rating use

When the altitude is higher than 1000m, the cooling effect is deteriorated because of the rarefaction of air; the de-rating method must be used. Please refer to our company for detailed technical support.

1.2.11 Some special usages

If customer needs to use other wiring methods beyond the graphs in the manual, please contact our company..

1.2.12 Disposal of controller

The electrolytic capacitors in the main circuits and PCB may explode when they are burned and poisonous gas may be generated when the plastic parts are burned. Please dispose the controller as industrial rubbish.

1.2.13 About adapt motor

- The standardized applicable motor of controller is four-pole squirrel-cage asynchronous motor. Please pay attention to the useable range of the controller rated current when select the applicable motor.
- The cooling fan and rotor axis of the un-conversion motor is linked in the same axis. When the rotor speed slows down, the fan cooling effect will be

reduced too. Therefore, customer should add strong exhaust fan or replace the motor into variable frequency motor in the circumstance of motor overheat.

➤ Short circuit inside the cable or motor will result in the controller alarm, even exploded the motor. Please do the insulating-short-circuit test at beginning. This test is also necessary in the daily maintenance. When doing this test, the controller and tested part must be cut off completely.

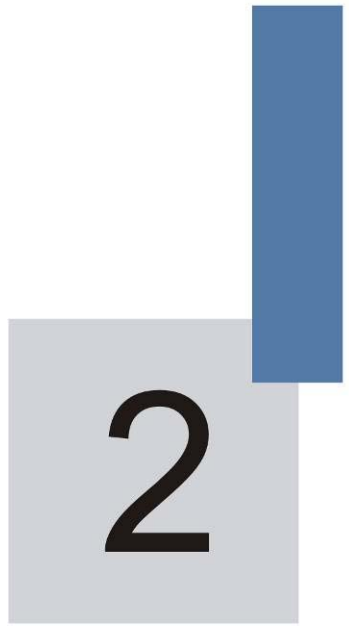

Product Information

Chapter 2 Product Information

Summarize:

In this chapter we introduce NICE2000 elevator control system in details, including related information of each part, daily usage and maintenance, type selection instruction of it and so on. It will help the clients to use our products safely.

2.1 Name designation rules

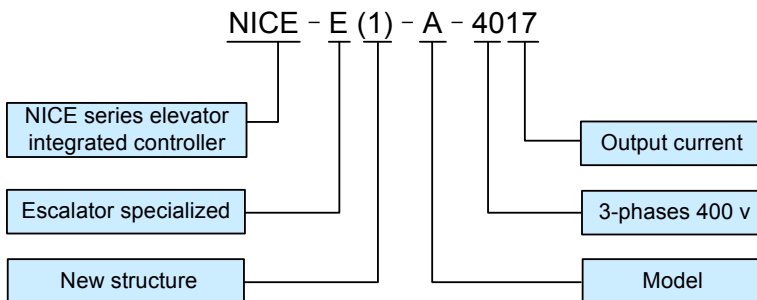

2.2 Nameplate

MODEL:	NICE-E (1) -A-4017
POWER	7.5kW
INPUT	3PH AC380V 20.5A 50Hz~60Hz
OUTPUT:	3PH AC380V 17A 0Hz~90Hz
S/N:	Barcode

2.3 Controller models

NICE2000 model	Input voltage	Power capacity (KVA)	Input current (A)	Output current (A)	Output power (KW)
NICE-E-A-4013	Three-phase380V Range : -15%~20%	8.9	14.6	13.0	5.5
NICE-E-A-4017		11.0	20.5	17.0	7.5
NICE-E-A-4025		17.0	26.0	25.0	11
NICE-E-A-4032		21.0	35.0	32.0	15
NICE-E-A-4037		24.0	38.5	37.0	18.5
NICE-E-A-4045		30.0	46.5	45.0	22
NICE-E-A-4060		40.0	62.0	60.0	30

2.4 Technical Specification

Item		specification
Basic Specification	Max .output frequency	90Hz
	Carrier frequency	0.5K~16K (Hz); carrier frequency can be adjusted automatically according to the load characteristic.
	Control mode	elevator special control mode
	Start torque	0.5Hz/180%
	Speed control range	1 :100
	Speed accuracy	±0.5%
	Torque accuracy	±5%
	Overload capability	150%rated current for 60s; 180%rated current for 1s
	Motor tuning	Static tuning , complete tuning
	Speedup/down curve	S-Curve, can be set flexibly
	Fault protection	40 kinds of protective functions, as Electrify short circuit survey, input/output phases loss protection, over-current protection, prevent reversion, etc.
Electrify peripheral	Implement electrify and do peripheral equipment	

Item		specification
	equipment safety auto-check	detection like grounding、short circuit etc.
	State monitor	Judge the work state according to feedback signals to ensure the escalator work effectively.
I / O interface	Switch input	19 switch input terminal, input specification:24V, 5mA
	Switch output	12 relay output, with corresponding function setup neatly
	Analogue	2 analogue input terminals, 1 analogue output terminal
Display and keypad	Operation panel	5-bit LED display, with operating speed and bus voltage parameters.
	Computer monitor	Monitor the parameters in all states
Application environment	Altitude	Lower than 1000m
	Ambient temperature	-10℃~+40℃(ambient temperature is within40℃~50℃ duration is required)
	Humidity	Less than 95%RH, without condensation
	Vibration	Less than 5.9m/s ² (0.6g)
	Storage temperature	-20℃~+60℃

2.5 Product appearance and installation holes dimension

2.5.1 Serial Product appearance

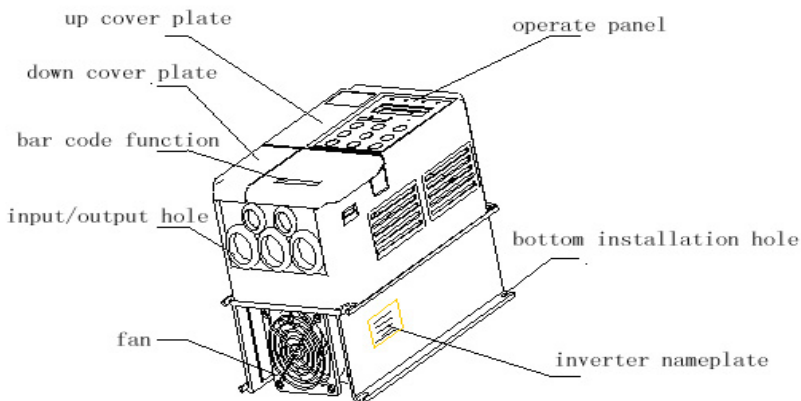

Fig 2-1 controller appearance

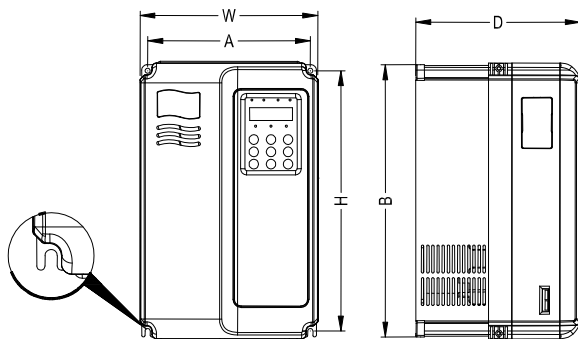

Fig 2-2 size and installation holes dimension

2.5.2 Installation holes dimension

Table: 2-3

Controller type	A (mm)	B (mm)	H (m)	W (mm)	D (mm)	aperture (mm)	Gross weight (kg)
NICE-E-A-4013	148	236	246	158	165	φ5.4	4
NICE-E-A-4017	150	335	348	223	177	φ6.5	10
NICE-E-A-4025							
NICE-E-A-4032							

Controller type	A (mm)	B (mm)	H (m)	W (mm)	D (mm)	aperture (mm)	Gross weight (kg)
NICE-E-A-4037	235	447	460	285	220	φ6.5	14
NICE-E-A-4045							
NICE-E-A-4060							

2.6 option units

Table: 2-4

Name	Type	Function	Remark
Outside lead LED operate panel	MCTC-OPR-A	Lead LED display and operate keyboard outside	Adopt RJ45 interface, super distance use
Extend cable	MCTC-OPL-0 150	Standardized 8 chip wire	Different specifications provided (such as 1.5 meter)
Synchronous switch card	MCTC-TBB-A	Bypass variable frequency synchronous switch card (as fig 2-3 instruction)	Smooth transition of convert frequency and work frequency

If option units listed above needed, please illuminate while ordering.

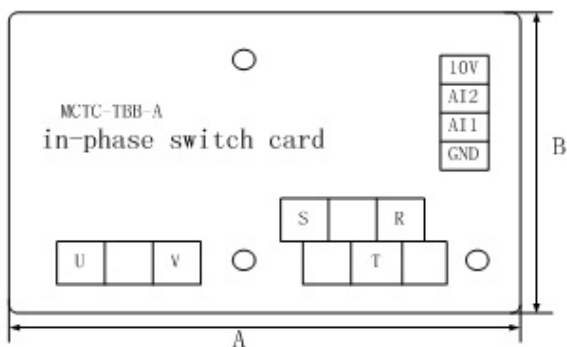

Fig 2-3 MCTC-TBB-A synchronous switch card

Specifications: A: 62mm B: 60mm Height: 25mm

Size of crust: Length: 68mm Width: 66mm Height: 25mm

2.7 Daily maintenance of controller

2.7.1 Daily maintenance

The components in the controller may become aging due to the influence of ambient temperature, humidity, dust and vibration, which will cause further potential faults and reduce the life of controller. Therefore, it is necessary to keep daily or periodic maintenance of controller.



Danger

Never do maintenance or repair work to the controller, since there still exist high voltage at filter capacitor after the power supply is switched off in a short time. Wait until the light "CHARGR" off, and the bus-voltage is lower than 36V.

1) Daily check items:

- Check if there is any abnormal noise during the running of the motor;
- Check if there is strong vibration of motor;
- Check if the installation environment of controller changes;
- Check if the cooling fan of controller works normally;
- Check if the controller is over heated.

2) Daily cleaning

- Always keep the controller in a clean state.
- Clean the dust on the controller and prevent the dust especially the metal powder;
- Clean the oil dirt in the cooling fan of the controller.

2.7.2 Periodical maintenance

It focuses on the places that can be hardly checked during the daily check.

1) Periodical maintenance items:

- Check the air channels and clean them periodically.
- Check whether the screws are loose.
- Check whether the controller is rusted.
- Check whether the input / output terminals have scratch or pulling trace.
- Insulation test in main circuit.

➤ Note: Insulation test (use 500V Mega-Ohm-Meter) should be done separately after disconnecting the input power cables from the controller. Dielectric strength test is not necessary since this test had been done at factory.

2) Replacement of damageable units of controller

The damageable parts include the cooling fan and filtering electrolytic capacitor, whose life is highly related with the operating environment and maintenance.

Table 2-5:

Component	Lifetime
Cooling fan	2 ~ 3years
Electrolytic capacitor	4 ~ 5years

User can confirm the replacing period according to the operating state.

1) Cooling fan

Possible damage causes: bearing attrition and blade aging.

Judging criteria: if there is crack on fan blade, or abnormal vibration noise at start.

2) Electrolytic capacitor

Possible damage causes: poor quality input electric power, high ambient temperature, big pulsating current due to frequent load fluctuation, electrolyte aging

Judging criteria: No liquid leak, protuberant safety valve, and electrostatic capacitance test, and insulation resistance test.

2.7.3 Storage of controller

The following points must be followed in controller storage:

- 1) It is recommended to store the controller in its original packing box.
- 2) Long-term storage will cause deterioration of electrolytic capacitor. Therefore, the controller must be power on at least once within 2 years and for at least 5 hours to restore the capacitors of the controller, and the input voltage must be boosted gradually with voltage regulator to the rated value.



Installation and Wiring

Chapter 3 Installation and Wiring

Do open the packing and check the controller before installation. Please confirm these information listed below carefully:

- 1) Check that if the model and the rated power is complied with your order. Your ordered machine, product certification, user manual and warranty card will be in the package.
- 2) Check if the machine is broken during the transportation; if there is any miss or damage, please contact with our company or agent as soon as possible.

Note: Installation and wiring should strictly comply with the criterions in chapter 1.

3.1 Mechanical installation

- 1) Installation environment
 - a) Temperature: The ambient temperature will bring great affect to the life of controller. The allowable extent is $-10^{\circ}\text{C}\sim+50^{\circ}\text{C}$.
 - b) Mount the controller on incombustible surface (such as metal) with enough space to spread heat. And use screw to mount it vertically on the bracket.
 - c) Mount the controller at places with less than 0.6G vibration. Never near punch and kindred equipment.
 - d) Avoid places with direct sunshine or dampness.
 - e) Avoid place with corrosive, flammable, explosive gas
 - f) Avoid places with oil dirt, dust or metal powder.
- 2) Installation position

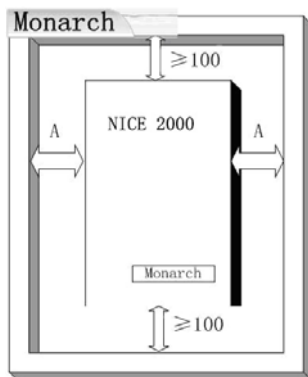

Fig 3-1 installation position

Instruction:

When the controller power is less than 22kw, the size of A can be left out of account; and when the controller power is more than 22kw, A shall be bigger than 50mm.

Heat dissipation is a big issue, so pay attention to the notices below:

- 1) Please install the controller vertically to be convenient for heat dispelling upwards. Never invert.
- 2) The installation space should be absolutely conforming to Fig 3-1 to make sure the heat dissipation of the machine. And do not forget the heat situation of other parts in the cabinet.
- 3) Installation bracket should be incombustible material.
- 4) As to the hermetic places with powder, the space should be enough.

3) Teardown and installation of panel

NICE2000 controller (under 15KW) adopts plastic shell, the teardown and installation information is in Fig 3-2.

- 1) Teardown: Find the pothooks under the plate, and push towards inside, using tools.
- 2) Installation: First, put the upside meatus (at the down cover plate) into the apertures (at the up cover plate), then press forcibly downwards until hearing the sound of “chatter”.

Note: Don't teardown the main part of the plastic shell. please contact our company if repairing needed.

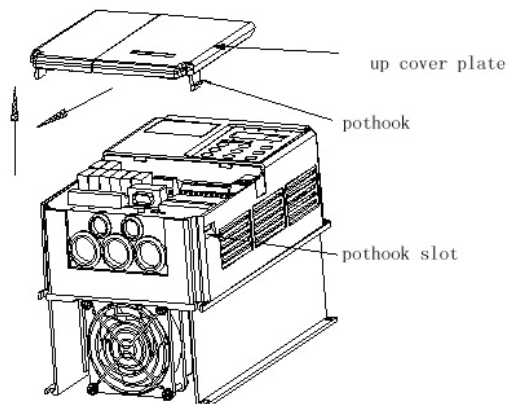

Fig 3-2 teardown and installation of cover plate under plastic shell

NICE2000 controllers above 18.5KW adopt sheetmetal shell; the teardown steps of bottom cover plate under sheetmetal shell are listed below:

- 1) Loose the screw of down cover plate directly, using tool.
- 2) Raise the down plate lightly.
- 3) Draw out the down plate backwards lightly.

The installation steps are reversed to teardown steps.

Note: please keep the down cover plate away from falling when teardown it to avoid equipment damage and human injury.

3.2 Electric part installation.

3.2.1 Selecting instructions of external electric components

Table 3-1

Type	Vacancy (MCCB) (A)	Contact or (A)	Input main circuit wire (mm ²)	Output main circuit wire (mm ²)	Control wire (mm ²)	Earth line (mm ²)
NICE-E-A-4013	32	25	6	6	1	4
NICE-E-A-4017	40	32	6	6	1	4
NICE-E-A-4025	63	40	6	6	1	4
NICE-E-A-4032	63	40	6	6	1	4

Type	Vacancy (MCCB) (A)	Contact or (A)	Input main circuit wire (mm ²)	Output main circuit wire (mm ²)	Control wire (mm ²)	Earth line (mm ²)
NICE-E-A-4037	100	63	10	10	1	4
NICE-E-A-4045	100	63	10	10	1	4
NICE-E-A-4060	125	100	16	16	1	4

3.2.2 Instructions of using the external electric components

Table 3-2

Name	Installation position	Function
Air circuit breaker	Forefront of input circuit	Cut off the power and provide short protection. This switch is essential.
Contactors	Between air circuit breaker and input side of controller	Switch on/off to operate controller; Avoid the contactor's frequent switch on/off to control the electric power directly.
AC input reactor	Input side of controller	1) Improve input power factor; 2) Eliminate high-frequency harmonics in input side; protect the rectifier bridge. 3) Eliminate current unbalance due to input phase unbalance; If after DC reactor installed, these demands can not be met yet, select AC reactor.
DC reactor	NICE2000controller 7.5~30KW DC reactor (standard)	1) Improve input power factor; 2) Eliminate high-frequency harmonics in input side; 3) Eliminate current unbalance due to input phase unbalance, but inferior to AC reactor. DC reactor, which has smaller size and do not lower voltage in the loop, so it is recommended to select DC reactor. Our company adopts this kind of reactor as standard component.

Name	Installation position	Function
<p>AC output reactor</p>	<p>Between output side of controller and motor, and near controller</p>	<p>There is always high-frequency harmonics at output side of controller. When the distance between controller and motor is too far, there will be some distributed capacitance in the circuitry. Some harmonics may generate resonance, causing influence in two aspects: 1) Destroy motor insulated capability, and may cause damage to motor. 2)Generate big leakage current, bringing forth controller continual protection. If the distance between the controller and the motor is more than 100m, it is recommended to install the AC output reactor.</p>

3.2.3 Electric connection

 **Danger**

- Make sure to do the wiring operation when the power supply switch is "OFF", otherwise there will be danger of electric shock!
- Only the specialist can do the job, or it may cause damage to equipment or human injury.
- The earth line should be implemented according to special criterion, otherwise there will be danger of electric shock or fire!

 **Caution**

- Make sure the input power of controller comply with supplied power, otherwise the controller may be damaged.
- Make sure the connected motor match with the application motor, otherwise there will be damage the motor and arose controller protection!
- Do not connect power with the terminal U, V, W, otherwise the controller may be damaged!

3.2.3.1 Connecting method

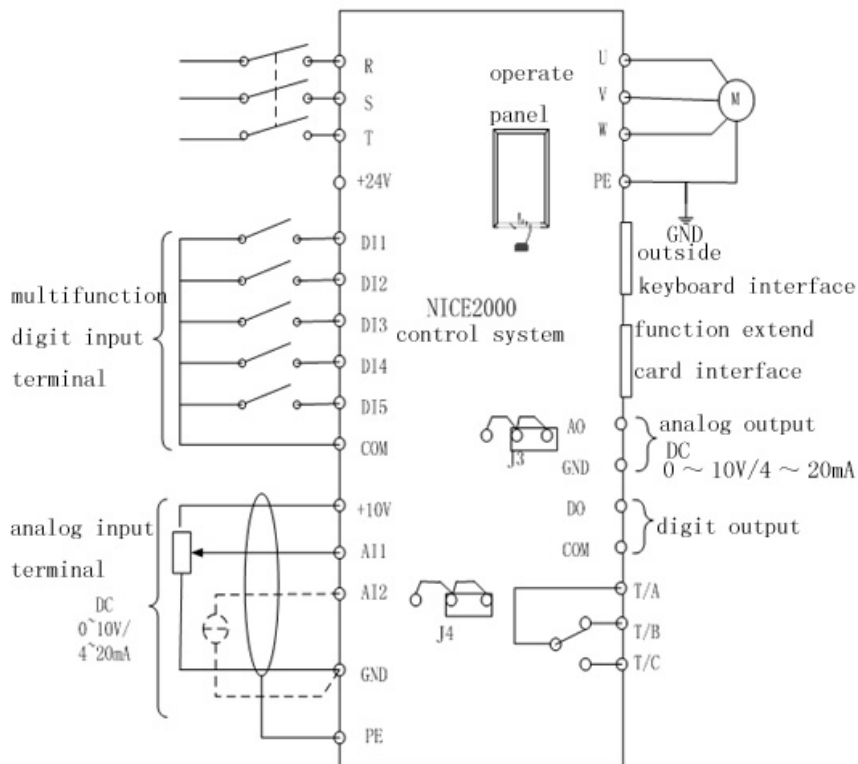

Fig 3-3 controllers applied to NICE-E-A-4013 ~NICE-E-A-4060

Bypass usage: applied to full range power

Full variable frequency usage: applied to 4013~4060 models

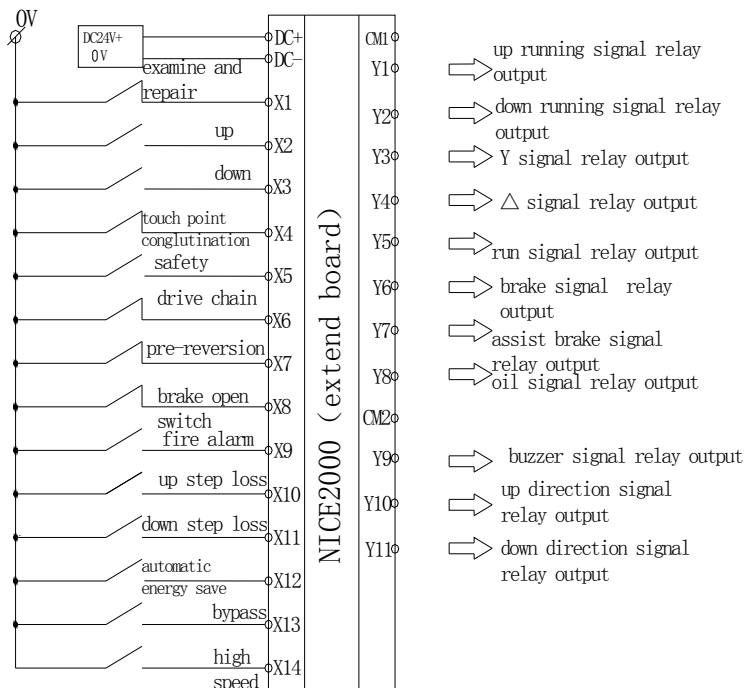

Fig 3-4 expansion boards (applied to NICE-E (1)-A-4013~NICE-E-A-4060)

The function of expansion input and output terminals can be set neatly, and the function in Fig3-4 is factory default.

3.2.3.2 Main circuit terminal and its circuit

- a) Instruction of main circuit terminal's function

Table 3-3

Terminal	Name	Instruction
R,S,T	3-phase power input terminal	3-phase AC 380v
(+),(-)	Position and negative terminals of DC bus	Shared DC bus input, for controller above 37KW, they are for brake unit.
P(+),PB	Terminals for break resistor	For controller below 30KW (include 30KW) they are for brake unit.

Terminal	Name	Instruction
U,V,W	Controller output terminal	Connect 3-phase motor
PE	Terminal for grounding	Grounding terminal

- b) Cautions in wiring
 - a) DC bus (+) and (-) terminals:

Please pay attention that the DC bus terminals (+) and (-) still have voltage after power off, and the user cannot touch the terminals until the indicator light “CHARGE” turns off and the voltage is below 36V.

Do not connect the brake resistance with DC current bus directly; otherwise it may cause damage to controller or even fire.

- b) Controller output side U,V, W

The output side of controller should connect to 3-phase motor. When the motor operating direction is reversed with the actual requirement, change any two of the U, V, W cables to change the operating direction.

The output of controller cannot connect to capacitors or inrush absorber, otherwise it may cause frequent protection of the controller or damage to it.

Controller output circuit earth line or short circuit is forbidden.

Controller output cables of U, V and W should be in metal pipe with earth line, and divided or vertical with control circuit cables.

If the cables between the motor and the controller are too long, electrical resonance may occur due to the distributed capacitance, which may result in damage to the motor insulation or leakage current that will make the controller go into protective status. Usually, the cable length should be less than 100m. It is recommended to add AC output reactor when the length is above 100m.

- c) Grounding terminal

Grounding terminal must be connected to the ground reliably. The ground cable should be thick and short, and we recommend using special yellow-green cable above 4 square mm with several copper cores. And the grounding resistance shall be less than 5Ω. Do not share the GE (ground electrode) and neutral line of main supply

3.2.3.3 Terminal and its wiring

1. Terminal collocation in controller circuit.

+10V	AI 1	AI 2	DI 1	DI 2	DI 3	DI 4	DI 5	COM
------	------	------	------	------	------	------	------	-----

GND	GND	AO1	CME	COM	DO1	FM	+24V	OP	T/A	T/B	T/C
-----	-----	-----	-----	-----	-----	----	------	----	-----	-----	-----

2. Function instructions of control terminals

Table 3-4

Sort	Terminal sign	Terminal name	Function instruction
Power supply	+10V-GND	External connect +10V power	1. Supply +10V electrical power to exterior, the most output current:10mA 2. Usually work as external potentiometer, range of potentiometer resistance:1~5KΩ
	+24V-COM	External connect +24V power	Supply +24V power to exterior, generally used for digit input terminal work power and outside sensor power; Max output current:200mA
	OP	Exterior power supply input terminal	1. Factory default is connecting with +24V. 2. When using exterior signal to drive the DI1~DI5, OP and +24V electric terminal should cut off, and connect with exterior 24V power.
Analog input	AI1-GND	Analogue input terminal 1	Range of input voltage :DC 0~10V Input impedance :100KΩ
	AI2-GND	Analogue input terminal 2	1. Input range: DC 0~10V/4~20mA, determined by jumper J3 of control boar. 2. Input impedance: voltage input:100KΩ, current input:500Ω
Digit input terminal	DI1-COM	Digit input 15	1. Optocoupler isolation, double polarity input 2. Input impedance :3.3KΩ 3. Input voltage range :0~30V
	DI2-COM	Digit input 16	
	DI3-COM	Digit input 17	
	DI4-COM	Digit input 18	
	DI5-COM	Digit input 19 (high speed pulse)	Can be used as high speed pulse input channel, besides characteristics of DO1~DO4.
Analogue output	AO1-GND	Analogue output	1.Output voltage or current determined by jumper J4 in control board.

Sort	Terminal sign	Terminal name	Function instruction
			2. Output voltage specification:0~10V 3. Output current specification:0~2mA
Digit output	DO1-CNICE	Analogue output	Optocoupler isolation, double polarity open circuit collector output type. Output voltage specification :0~24V Output current specification :0~50mA Note: CME and COM is isolated inside, but CME and COM have jump out (DO1 default: +24V driven); when DO1 wants to use exterior power drive, the outside jumper between CNICE and COM should be cut off.
	FM-COM	Reservation	
Relay output	T/A-T/B	Normal close Terminal	Contact driving capacity: AC : 250V, 3A, Cosφ=0.4 DC : 30V, 1A Relay output Y12, function setup determined by F5-12 parameters.
	T/A-T/C	Normal open Terminal	
Auxiliary interface	J1	Function expansion card	28-core terminal, special interface card
	J2	PG card	PG card special interface
	CN3	Outside bring keyboard	Outside-bring keyboard, parameter-copy-unit interface

3. I/O extend board terminal configuration

CM1	Y1	Y2	Y3	Y4	Y5	Y6	Y7	Y8
-----	----	----	----	----	----	----	----	----

RX-	RX+	CM2	Y9	Y10	Y11
-----	-----	-----	----	-----	-----

X	X	X	X	X	X	X	X	X	X	X	X	X	X	DC	D
1	2	3	4	5	6	7	8	9	10	11	12	13	14	+	C-

4. Function instruction of I/O expansion board terminal

Sort	Sign	Name	Function instruction
Power supply	DC+~DC-	External connect +24V power	NICE2000 adopts exterior +24V power, usually used as digit input terminal work power.

Sort	Sign	Name	Function instruction
Digit input terminal	X1	Digit input 1	1. Optocoupler isolation, low level input is avail 2. Input impedance:3.3KΩ 3. Input voltage range:0~30V
	X2	Digit input 2	
	X3	Digit input 3	
	X4	Digit input 4	
	X5	Digit input 5	
	X6	Digit input 6	
	X7	Digit input 7	
	X8	Digit input 8	
	X9	Digit input 9	
	X10	Digit input 10	
	X11	Digit input 11	
	X12	Digit input 12	
	X13	Digit input 13	
	X14	Digit input 14	
Relay output	Y1~CM1	Relay output 1	Contacts driving capacity: AC : 250V, 3A, Cosφ=0.4 DC : 30V, 1A Note : CM1 and CM2 are cut off inside
	Y2~CM1	Relay output 2	
	Y3~CM1	Relay output 3	
	Y4~CM1	Relay output 4	
	Y5~CM1	Relay output 5	
	Y6~CM1	Relay output 6	
	Y7~CM1	Relay output 7	
	Y8~CM1	Relay output 8	
	Y9~CM2	Relay output 9	
	Y10~CM2	Relay output 10	
	Y11~CM2	Relay output 11	
Communication terminal	RX-	MODBUS communication	Shielded-twist-pair wire (STP) is recommended
	RX+		

5. Instruction of terminal connection

A. Analogue input terminal

The feeble analogue signal is apt to be influenced from outside interferer, so shielded cable is needed commonly, and the wiring length should be no more than 20 meters. Make sure to keep the shield layer which closed to controller well grounded. Refer to Fig 3-5.

In the situation of some serious interfere, filter or ferrite magnetic core should

be added at the side of analogue signal source. Refer to Fig 3-6.

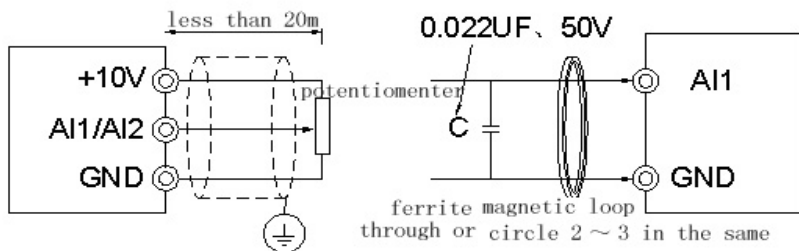

Fig 3-5 Terminal connection

Fig 3-6 Signal disposal connection

B. Digital input terminal

Shielded cable or twisted line are usually used in wiring (refer to 3.2.1 external electric components), and the wiring length must be as short as possible (less than 20 meters). If use shielded line, please connect shielded layer into terminal PE which is near the side of controller.

When using active drive, filter measure is essential to avoid serial interfere.

It is recommended to use contact control mode.

C. Digital output terminal

When digital output terminals need to drive the relay, absorbing diode should be added at both sides of relay loop. Otherwise the DC 24V power will be damaged.

Note: Absorbing diode must be setup correctly, which means its polarities have to be installed properly. Otherwise when the digital output terminal have output, it will burn out the DC 24V power immediately.

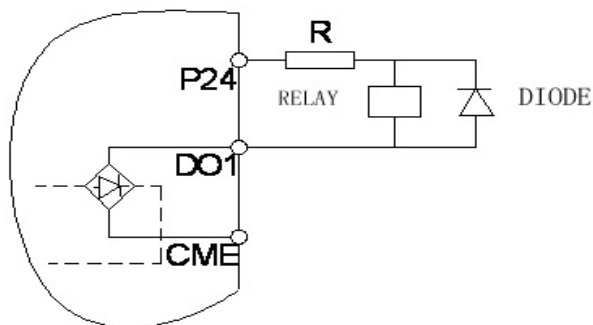

Fig 3-7 connection sketch of digital output terminal

3.3 The solution for EMC problem

3.3.1 Influence of harmonics

1) The electric power has high-frequency harmonics in itself and will produce great influence to the rectify part, making the rectify bridge work for a long time so that the excessive heat may cause the work point drifting and harmful to the rectify bridge. If the power supply system is not so good in some place, it is suggested that add filter or AC input reactor between the electric power and controller, or install DC reactor at controller bus, to settle the harmonics problem so that protect the controller.

2) The controller output side will produce high-frequency harmonics, if adding capacitance or inrush suppresser which aims to improve power factor, will bring loop current shake, and lead to equipment damage. So capacitance or inrush suppressive equipment is forbidden to been added at output side.

3.3.2 Electromagnetic interference and its disposal

There are two kinds of electromagnetic interferences

1. **The first one is the surrounding electromagnetic noise interference**, which will bring the controller mis-activation. Generally speaking, this kind of interfere will not cause great influence; because this part has been high-test when designing the controller. It has comparatively strong anti-jamming capacity.

Premises to settle the problems: a) the controller is well grounded, and the earthing resistance can not be more than 5Ω ; b) drive power line of the controller should not parallel with control line; if permitted, try to collocate

vertically; c) at the place with high interfering request, shielded cable between controller and motor should be adopted and keep shielded layer well grounded. d) as to the down-lead which suffer the influence of interference, it is suggested to use double-twist shielded line, and keep the shielded layer well grounded.

There are two kinds of surrounding electromagnetic noise interferences: one is controller's radiation, the other is produced by the down-leads between controller and motor. Both will bring electromagnetism or electrostatic induction to the surface of the surrounding equipments.

Common solutions are listed below:

1) Apparatus, receivers or sensors which are used for measuring, usually have the feeble signal around. If closed to controller or in the same control panel, they are liable to get interference and come into malfunction. It is recommended to use following solutions: keep away from the interfere power; don't make the signal line parallel to the driving line, and parallel enlacement together is especially prohibitive; the signal line and driving line should adopt shielded cable; add linear filter or wireless noise filter in the input and output side of the controller.

2) When interfered equipment and controller use the same power, the best bet is to add linear filter or wireless noise filter between the controller and power if the interference isn't alleviative by the above solutions.

3) Earth the peripheral equipments separately, which can eliminate the interference generated by grounding line's leakage current due to earthing together.

2. The other one is interference produced by the surrounding equipment.

The ecumenical reason is that there are large numbers of relays, contactors or electromagnetic arresters around the controller.

When facing with this kind of problem, use the following methods:

1) Add inrush suppresser in the equipment which produce interfere.

2) Add filter at the signal input terminal of the controller.

3.3.3 Electric leakage and its disposal

There are two forms of electric leakage when using controller: 1) leakage current to earth; 2) leakage among the lines.

1) **Factors influencing leakage current to earth and solution.**

There are distributed capacitance between lead and earth. The more the distributed capacitance is, the larger the leakage current will be; to minish the distance between the controller and motor will reduce the distributed capacitance.

The higher the carrier frequency is, the larger the leakage current will be; we can reduce carrier frequency to reduce leakage current; but remember that it will increase the motor noise.

Adding reactor is also an efficient way to resolve the leakage current.

2) Leakage current will be increased with the increase of loop current; therefore, large motor power will lead to corresponding large leakage current.

3) **Factors influencing leakage current among the lines and solution.**

There exists distributed capacitance among the controller output lines; if the current passing circuitry has high-frequency harmonics, resonance will occur and then lead to leakage current. Using thermal overload relay here will cause malfunction.

The resolvent is to reduce carrier frequency or to add output reactor. It is not suggested that to add thermal overload relay in the front of motor when using the controller; use the electro-over-current protective function of the controller.



4

Operation and Test-run of controller

Chapter 4 Operation and Test-run of controller

Summarize: we will give detailed information in operating keyboard and function code setting of display panel of the NICE2000 in this chapter.

4.1 technical terms of NICE2000 controller

Main parts: operation mode, control mode, running mode and working state.

4.1.1 Operation mode

The definition of operation mode: it is the modes of receiving running command and speed instruction. NICE2000 control system can select only one of the operating modes hereinafter.

- 1) Operating panel control: use the key RUN and STOP of the operating panel to control the controller output.
- 2) Command control terminal: the running command and running speed are controlled by multi-functional input signal of input terminal.

4.1.2 Running mode

NICE2000 control system can select only one of the control modes hereinafter.

- 1) Self-tuning running mode: NICE2000 control system provides self learning mode under loaded state and unloaded state. For details, please refer to parameter F1-11.
- 2) Common running mode: running under the control of operating panel.
- 3) Elevator control mode: the running speed is controlled according to the logic state of elevator control carry through auto selection.

4.1.3 Working state

NICE2000 control system have four states in live state: stop state, program state, running state and fault-alarm state.

- 1) Stop state:

Re-electrify or stop after running command finished, the controller is always at the wait state until receiving another running command. At this moment, indicator light will go out, with the contents in LED screen flashing; can use key “»” to display different parameter circularly.

- 2) Program state:

Examine and set up the parameters through operating panel of controller.

3) Running state:

The running indicator light is on when the controller is at the state of running, with the contents in LED screen un-flashing

4) Fault alarm state:

There comes fault of controller and the fault code is displayed.

4.2 Introduction of operation and display panel

Operation keyboard with LED display is the standardized configuration of NICE2000 control system. Through this keyboard, user can modify the function parameter, monitor working state of controller, and control its running state (start or stop).

As to the appearance and function section, please refer to Fig 4-1.



Fig 4-1 operating panel

1) Instructions of functional indicate lamp:

RUN	If it is on, controller is working.
LOCAL/REMOT	It is the light of keyboard operation and long-distance operation. Light-on means the controller is in the state of long-distance operation state.
FWD/REV	Indicator light of forward and reversed rotation. Light-on means forward rotation.
TUNE	Tuning Indicator; if it is on, the controller is in tuning state.

2) Digital display area

5-bit LED display; it can display various monitor data and alarm codes, such as setting frequency, output frequency.

3) Instruction of units:

HZ frequency unit

V voltage unit

% percentage
 A current unit
 RPM rotation speed unit

4) Instruction of buttons on keyboard

Table 4-1 Keyboard function

Key	Name	Function
PRG	Program key	Enter and exit the first-level menu and delete quick parameter
ENTER	Confirm key	Enter the menu level by level and set parameter conformation
∧	Up key	Increase of data and function code
∨	Down key	Decrease of data and function code
》	Shift key	Select the display parameters circularly at stop state and running state. Select the modification bit when modifying parameters.
RUN	Run key	Start up the machine in the terms of keyboard operation mode.
STOP/RESET	Stop/Reset key	Stop the machine when the controller is in running. Reset the machine, when in the state of fault alarm.
QUICK	Quick key	Enter or exit the first-level of quick menu. Refer to QUICK operation instruction
MF.K	Multi-function selection key	Display and remove error information.

4.3 Function code examine & operation instruction

4.3.1 Operation flow of 3-level menu

NICE2000 adopts 3-level menu to conduct the parameter setting. It's convenient to query and modify function code and parameter.

3-level menu include: function parameter group (first level)→function code (second level)→function code setting(third level). You can refer to operation flow chart Fig4-2.

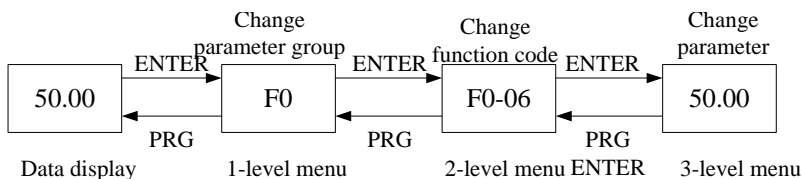

Fig 4-2 operation flow chart of 3level menu

Note: when in 3rd menu, system can be backed to 2nd menu by pressing “PRG” or “ENTER”. The difference between them: it goes back to 2th menu with parameter saved when pressing “ENTER”, then jump to next function code automatically; while it back to the 2nd menu with the parameter unsaved and it will stay in the current function code.

Example: change F0-04 from 50.00Hz to 15.00Hz (boldfaced words means flash bit)

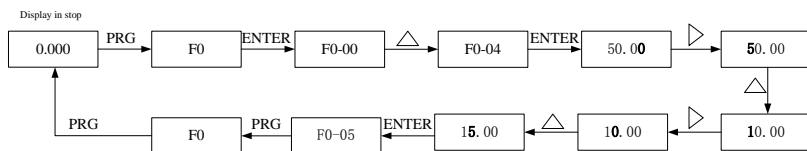

Fig 4-3 parameter editing operation process

In 3-level menu, if the parameter has no flash bit, it means the function code cannot be changed and the possible reasons are:

- 1) This function code is un-revisable, such as the actual examine parameter and running record parameter..
- 2) This function code cannot be changed in operating state and can only be changed when the controller is stopped.

4.3.2 Switch the state display parameters by shift key

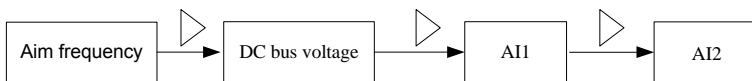

Fig 4-4 example of state display parameter switch

LED can display several status parameters when NICE2000 is in stop and running states. Detailed parameter content can refer to parameters F7-00(running parameter) ~ F7-01(stop parameter). Through key , user can shift the display in sequence and display the stopping or running state

parameters circularly.

In stop state, there are 4 parameters for NICE2000, and user can shift to display the parameters circularly by key . The parameters are: aim frequency, DC bus voltage, AI1 and AI2. Whether to display the status parameters is dependent on the bit setting of F7-01, through the key , user can shift the display in sequence and display the selected parameters.

In running state, there are 12 parameters: running frequency, aim frequency, DC bus voltage, output voltage, output current, AI1, AI2 etc. whether to display the status parameters is dependent on the bit setting of F7-00, through the key , user can shift the display in sequence and display the selected parameters.

4.3.3 Error information reading

When error occurs, the error information will be displayed on panel. It is convenient to find reason of error and get rid of the error as soon as possible.

NICE2000 controller can save the last 11 error code and record the last 3 error frequency, current, bus voltage, digit input terminal state and digit output terminal state. The relative sketch map is listed below:



Fig 4-5 error information reading

4.3.4 Monitor digit input and output terminal state

Refer to F7-11, F7-12 parameter instruction in chapter6.

4.4 Operation mode of shortcut menu

Quick menu is created with the purpose of making it convenient for user to check and modify the parameter in common use. The parameter display mode in quick menu is “uF3-02”, which means the function parameter “F3-02”. The effect of changing the parameter in quick menu is the same with that in the common programming status

At most 16 parameters can be saved in quick menu. If 16 parameters are stored and want to add more, it will show “FULL”; if enter the menu, it will show “NULL”, which means no parameter is stored in the menu. 16 parameters already have been stored in quick menu at the beginning.

F0-01: Driving mode	FB-07 : Automatic oil cycle time
F6-03: fast 1 running frequency	FB-08 : Startup buzzer keep time
F6-04: fast 2 running frequency	FB-09 : fast running keep time
F6-05 : Slow running frequency	FB-10 : Slow running keep time
F6-09 : Examine and repair frequency	FB-11 : Reverse into running time
FB-00 : fast 1 sensor detect time	FB-13 : Brake open detect time
FB-03 : fast 1 host motor pulse	FB-16 : Mode of energy save selection
FB-06 : Automatic oil keep time	FB-17 : Whole automatic function selection

User can edit according to actual demand.

4.4.1 Add shortcut menu parameters

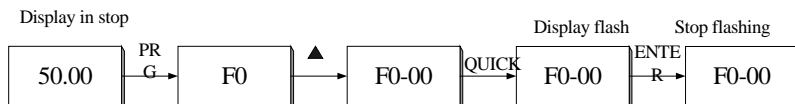

Fig 4-6 setup of quick menu

Note: When pressing “QUICK” in second level menu with the displayed contents flashing (which prompt the user to save the parameter into the quick menu or not), then press “ENTER”; the contents will stop flashing so that the whole operation finished. While pressing PRG, it will not save the parameter into the quick menu and the displayed parameter stops flashing so that the operation is cancelled.

4.4.2 Modify & retrieve the shortcut menu parameters

Example: change the parameters F0-00, F1-11, F4-13 and F8-03:

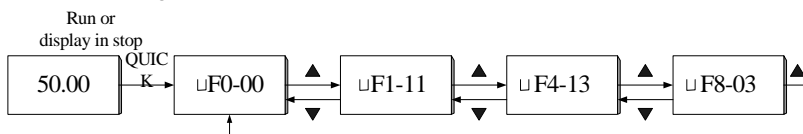

Fig 4—7 retrieve the parameter in quick menu

Note: In stop or run display interface, press “QUICK” to enter quick menu, and press “UP/DOWN” to select different parameters, then press “ENTER” to enter the next level menu, here, the changing method is the same with that in third

level menu. Press “QUICK” to back to last screen and the changed parameter will not be saved.

4.4.3 Delete the parameter in the quick menu

There are parameters as F0-00, F1-11, F4-13 and F8-03 in quick menu. If you want to delete F4-13, please operate as the following

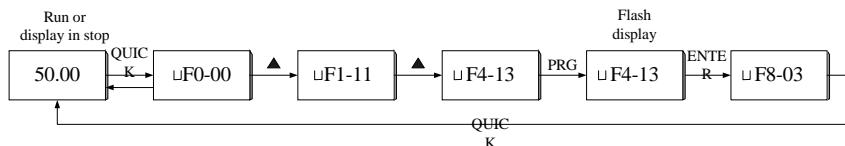

Fig 4-8 Deletion of shortcut menu

Note: Press “PRG” in the quick menu with displayed contents flashing (which prompt the user to delete this parameter or not); then press “ENTER”, it will delete the parameter in the menu, and the contents will stop flashing so that the whole operation finished. While pressing “QUICK”, it will cancel the operation and the displayed parameter stops flashing. If the last parameter is deleted, “NULL” will be displayed, that means no parameter is stored in the menu.

4.5 Password setting

In order to protect the parameter more effectively, NICE2000 provides the password protection.

The figure below shows how to set the password to 12345.

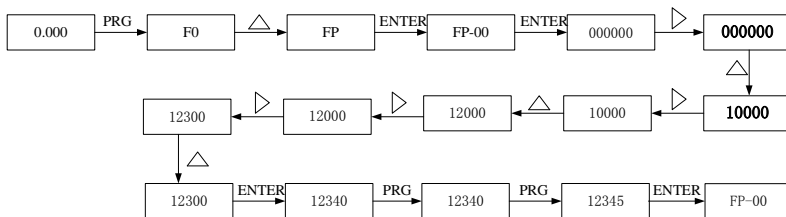

Fig 4-9 process of password setting

After setting the function password (parameter FP.00 is not zero), if the user presses “PRG”, the controller will enter into password validate state first and display“-----”. User can only enter the menu after inputting the user password. For factory setting parameters editing, the user still need to input the factory password. (Warning: do not change the factory setting parameter; if the

parameter values are wrong, the controller will work abnormally, even be damaged.)

When the password protection is unlocked, user can change the password freely, and the last input will be the user password.

If the user wants to cancel the password protection function, enter after inputting the password and setting FP.00 as 0; if FP.00 is not zero, the parameter is password protected.

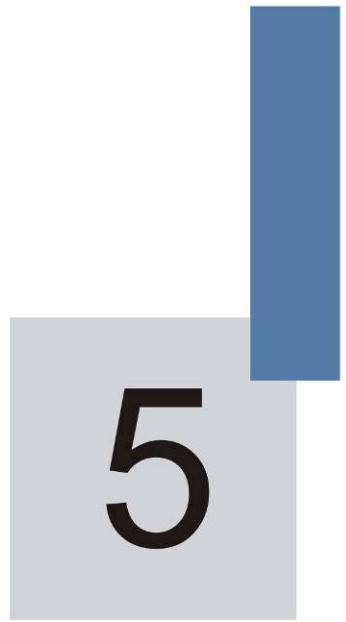

Function Parameter Table

Chapter 5 Function parameter Table

5.1 Instruction of function parameters

1. Function parameters are classified into 13 groups. Each group has several function codes. The function code uses 3-level menu with the format “F X-XX”, which means “No. XX function code in group X”. For example, F 8-08 means the No.8 function code in group F8.

In order to make functional code setting convenient, the function group number corresponds to first level menu, the function code number corresponds to second level menu, and function code parameters correspond to third level menu.

2. The contents of function codes:

Column 1“function code”, means the serial number for function parameter group and parameter;

Column 2“name”, means the complete name of the function parameter;

Column 3“setting range”, means the parameter setting range;

Column 4“minimum unit”, means the minimum unit of the parameter setting;

Column 5“factory setting”, means the original default;

Column 6“operation”, means the modification attributes of the parameters (whether to enable the modification and the modification requirements).

Instructions are listed below:

☆: the parameter can be modified while the NICE2000 is running or stopping;

★: the parameter can not be modified while the NICE2000 is running;

●: the parameter cannot be modified for it is actually measured and recorded.

3. “Factory Default” means the numeric value after the function code parameter is refreshed when recovering the default parameter, but the actually measured value or recorded value will not be refreshed.

4. The controller provides password protection of function code to protect the parameters effectively (detailed in Chapter 4).

5.2 Function parameter table

5.2.1 Groups of function parameters

Press PRG buttons and then UP/DOWN button, all of the displays are first level menu, which are group of function. Details as follows:

- F0——Basic parameter
- F1——motor parameter
- F2——vector control parameter
- F3——VF function parameter
- F4——input function parameter
- F5——output function parameter
- F6——up/down control parameter
- F7——assistant function parameter
- F8——auxiliary managing parameter
- F9——protect function parameter
- FA——communication parameter
- FB——elevator function parameter
- FF——factory parameter
- FP——user parameter

5.2.2 Function parameter table

Code	Name	Setting range	Min. unit	Default	Operation
F0 Group Basic parameter					
F0-00	Reserved	0~2	1	2	●
F0-01	Elevator drive mode	0 :operating panel control 1 :bypass variable frequency 2 :full variable frequency driving 3 :Y-△direct startup	1	1	★
F0-02	Frequency power setting	0 : interior digit setting	1	0	★
F0-03	Operating panel frequency	0.00Hz~F0-04	0.01Hz	0.00Hz	☆
F0-04	Max. frequency	50.00Hz~99.00Hz	0.01Hz	50.00Hz	★
F0-05	Carrier frequency	0.5~16.0kHz	0.1kHz	Depend on the model	☆
F0-06	Panel-controlled reverse running	0~1	1	0	★
F1 Group Motor parameter					
F1-00	Reserved	0~2	1	0	★
F1-01	Rated power	2.2~75.0kW	0.1kW	Depend on the model	★
F1-02	Rated voltage	0~440V	1V	380V	★

Code	Name	Setting range	Min. unit	Default	Operation
F1-03	Rated current	0.00~655.00A	0.01A	Depend on the model	★
F1-04	Rated frequency	0.00~99.00Hz	0.01Hz	50.00Hz	★
F1-05	Rated rotate speed	0~3000rpm	1 rpm	Depend on the model	★
F1-06	Stator resistance	0.001~30.000Ω	0.001Ω	Depend on the model	☆
F1-07	Rotor resistance	0.001~30.000Ω	0.001Ω	Depend on the model	☆
F1-08	Leakage inductance	0.01~300.00mH	0.01mH	Depend on the model	☆
F1-09	Mutual inductance	0.1~2000.0mH	0.1mH	Depend on the model	☆
F1-10	No-load current	0.01~300.00A	0.01A	Depend on the model	☆
F1-11	Tuning selection	0 :no tuning 1 :static tuning 2 :complete tuning	1	0	★
F1-12	Reserved				★
F1-13	Reserved				★
F2 Group Vector control parameters					
F2-00	Frequency tracing response speed	0~100	1	40	☆
F2-01	Frequency tracing constant speed delay time	0.01~10.00s	0.01s	0.60s	☆
F2-02	Switching frequency 1	0.00~F2-05	0.01Hz	2.00Hz	☆
F2-03	Proportional gain 2	0~100	1	30	☆

Code	Name	Setting range	Min. unit	Default	Operation
	of speed loop				
F2-04	Integration time 2 of speed loop	0.01~10.00s	0.01s	0.90s	☆
F2-05	Switching frequency 2	F2-02~F0-04	0.01Hz	5.00Hz	☆
F2-06	Frequency tracing current setting	50-130%	1%	100%	☆
F2-07	Filter coefficient of speed loop	0.00~5.00s	0.01s	0.00s	☆
F2-08	Upper limit of torque filter	0.0~200.0%	0.1%	150.0%	☆
F3 Group VF function parameter					
F3-00	Torque hoist	0.0:(automatic) 0.1%~30.0%	0.1%	1.0%	★
F3-01	Torque hoist frequency	0~F0-04	0.01Hz	50.00Hz	★
F3-02	Slip compensation	0.0~200.0%	0.1%	0.0%	★
F3-03	AVR select	0 :invalid 1 : valid of all process 2 :only invalid in deceleration	1	2	★
F3-04	Surge restrain gain	0~100	1	0	★
F4 Group Input function parameters					
F4-00	Input filter time	1~10	1	4	★
F4-01	Select terminal X 01	0:no function 1:N.O.input of safety circuit signal 2:N.O.input of inspection signal	1	26	★
F4-02	Select terminal X 02	3:N.O.input of up motion 4: N.O. input of down motion 5:N.O.input of	1	3	★

Code	Name	Setting range	Min. unit	Default	Operation
F4-03	Select terminal X 03		1	4	★
F4-04	Select terminal X 04		1	30	★
F4-05	Select terminal X 05		1	1	★
F4-06	Select terminal X 06		1	31	★
F4-07	Select terminal X 07		1	33	★
F4-08	Select terminal X 08		1	8	★
F4-09	Select terminal X 09		1	19	★
F4-10	Select terminal X 10		1	15	★
F4-11	Select terminal X 11		1	16	★

Code	Name	Setting range	Min. unit	Default	Operation
F4-12	Select terminal X 12		1	12	★
F4-13	Select terminal X 13		1	18	★
F4-14	Select terminal X 14		1	17	★
F4-15	Select terminal DI 1		1	13	★
F4-16	Select terminal DI 2		1	14	★
F4-17	Select terminal DI 3		1	10	★
F4-18	Select terminal DI 4		1	11	★
F4-19	Select terminal DI 5		1	5	★
F4-20	Reserved		1	0	★
F4-21	Reserved		1	0	★

Code	Name	Setting range	Min. unit	Default	Operation
F4-22	Safety brake delay time	0-65535 ms	1ms	500ms	★
F4-23	Frequency tracing error auto reset resetting	1-10s	1s	3s	★
F4-24	Time limit for frequency tracing	1-20s	1s	10s	★
F4-25	Time multiple for the first time	1~20	1	5	☆
F4-26	Ai apex selection	1000~1600	1	1350	☆
F4-27	Assistant function selection	0~65535	1	17	★
F4-28	Max. delayed-time for in-phase switch	2.000~10.000s	0.001	3.000s	☆
F4-29	Stable speed delayed-time for in-phase switch	0~2.000	0.001	0.5s	☆
F4-30	Filter time for in-phase analogue sampling	1~5	1	5	☆
F5 Group Output function parameters					
F5-00	Output select DO	0 :no function	1	0	★
F5-01	Select function of $\overline{Y4}$	1 :running contactor	1	2	★
F5-02	Select function of $\overline{Y2}$	2 :up motion (NET) contactor			
F5-03	Select function of $\overline{Y3}$	3 :down motion(NET) contactor			
F5-04	Select function of $\overline{Y1}$	4 :Y running contactor			
		5 : Δ running contactor			

Code	Name	Setting range	Min. unit	Default	Operation	
F5-05	Select function of VF		1	1	★	
F5-06	Select function of VF		1	6	★	
F5-07	select function of V7		1	7	★	
F5-08	select function of VF		1	12	★	
F5-09	select function of VF		1	11	★	
F5-10	select function of V40		1	9	★	
F5-11	select function of V44		1	10	★	
F5-12	select function of V40		1	8	★	
F5-13	reserved		1	0	★	
F5-14	reserved		1	0	★	
F5-15	reserved		1	0	★	
F5-16	Select output type		0~65535	1	65535	★
F5-17	AO bias		-100.0%~100.0%	0.1%	0.0%	☆
F5-18	AO gains		-10.00~10.00	0.01	1.00	☆
F5-19	AO output selection	0 :running frequency 1 :output voltage 2 :output current	1	0	★	
F6 Group Start/stop control parameters						
F6-00	variable frequency to work frequency switch time	0~2.0s	0.1s	0.2s	★	
F6-01	Work frequency to variable frequency switch time	0~2.0s	0.1s	0.2s	★	

Code	Name	Setting range	Min. unit	Default	Operation
F6-02	Conversion switch frequency	0~50.0Hz	0.01	43.0Hz	★
F6-03	Quick 1 running frequency	0~Max.frequency	0.01Hz	50.00Hz	★
F6-04	Quick 2 running frequency	0~Max.frequency	0.01Hz	30.00Hz	★
F6-05	Slow running frequency	0~Max.frequency	0.01Hz	20.00Hz	★
F6-06	Star- triangular switch of time extension	0~500MS	1MS	100MS	★
F6-07	Accelerate time	0.0~3000.0s	0.1s	4.0s	★
F6-08	Decelerate time	0.0~3000.0s	0.1s	60.0s	★
F6-09	Examining and repairing frequency	0.00~Max.frequency	0.01Hz	25.00Hz	★
F6-10	Inching (examine and repair) accelerate time	0.0~3000.0s	0.1s	20.0s	★
F6-11	Selection of inspection mode	0~1	1	0	★
F6-12	Up-frequency switch surplus	0~10.00Hz	0.01Hz	1.50Hz	★
F6-13	Down-frequency switch surplus	0~10.00Hz	0.01Hz	1.50Hz	★
F7 Group Assistant function parameters					
F7-00	Running parameter display	1~16383 Bit0 :running frequency Bit1 :aim frequency Bit2 :DC bus voltage Bit3 :output voltage Bit4 :output current Bit5 : AI1	1	16383	☆

Code	Name	Setting range	Min. unit	Default	Operation
		Bit6 : AI2 Bit7 :low bit of input state Bit8 :high bit of input state Bit9 :output state Bit10 :host motor pulse number Bit11 :handrail speed time interval Bit12 :step loss time interval Bit13 :in-out state display			
F7-01	Stop parameter display	1~255 Bit0 : aim frequency Bit1 : DC bus voltage Bit2 : AI1 Bit3 : AI2 Bit4 : pulse number of mainframe Bit5: interval of handrail speed-test Bit6: interval of step missing Bit7: input/output state display	1	255	☆
F7-02	Running time setting	0~60000hours	1	0	☆
F7-03	Cumulate working hours	0~65535hours	1	0	●
F7-04	reserved	0~3600	1	0	●
F7-05	Run time to action selection	0 :continue to run 1 :stop	1	0	★
F7-06	Electrify to ground short protect	0 :invalid 1 :avail	1	1	★

Code	Name	Setting range	Min. unit	Default	Operation
	detection				
F7-07	Brake usage rate	0~100%	1%	100%	★
F7-08	Software edition(ZK)1	000.00~999.99	0.01	*	●
F7-09	Software edition(DSP)2	000.00~999.99	0.01	*	●
F7-10	Radiator temperature	0~100℃	1℃	*	●
F7-11	Terminal input state	*	*	*	●
F7-12	Terminal output state	*	*	*	●
F8 Group Assistant management parameters					
F8-13	Switch coefficient of up in-phase	0~13	1	6	★
F8-14	Switch coefficient of down in-phase	0~13	1	6	★
F9 Group Protect function parameters					
F9-00	Overload protection selection	0 :forbid 1 :permit	1	1	☆
F9-01	Overload protection coefficient	0.20~10.00	0.01	1.00	☆
F9-02	Reserved	50~100%	1%	80%	☆
F9-03	Over-voltage stall gain	0(no over-voltage stall)~100	1	0	☆
F9-04	Over-voltage stall point	120~150%	1%	130%	☆
F9-05	Over-current stall gain	0~100	1	20	☆
F9-06	Over-current stall point	100~200%	1%	150%	☆
F9-07	Non-stop of Instant stop function	0 :forbid 1 :permit	1	0	☆
F9-08	Decline frequency	0.00Hz/s~ Max.	0.01Hz/s	10.00Hz/s	☆

Code	Name	Setting range	Min. unit	Default	Operation
	rate of non-stop of instant stop	frequency/s			
F9-09	Fault reset time	0~3	1	0	☆
F9-10	Fault reset interval	0.1~100.0s	0.1s	1.0s	☆
F9-11	Input phase failure select	0 :forbid 1 :permit	1	1	☆
F9-12	Output phase failure select	0 :forbid 1 :permit	1	1	☆
F9-13	Information of first error	0 :no error 1 :inverse unit protection 2 : accelerated over-current 3 : decelerated over-current 4 : constant over-current 5 : accelerated over-voltage 6 : decelerated over-voltage 7 : constant over-voltage 8 : controller power fault 9 : under-voltage fault 10 :inverter overload 11 :motor overload 12 : phase failure of input side 13 : phase failure of output side 14 :module overheated 15 :reserved	1	*	●

Code	Name	Setting range	Min. unit	Default	Operation
		16 :reserved 17 :contactor fault 18 :current detection fault 19 :motor tuning fault 20 :encoder fault 21 :data overflow 22 :reserved 23 :short circuit to ground fault 24~29 :reserved 30 : safety switch OFF 31 : driving chain OFF 32 :contact conglutination of contactor 33 : brake fault 34 : speed abnormal of left handrail 35 :speed abnormal of right handrail 36 : up step loss 37 : down step loss 38 : speed test fault 39 : non-reversion fault 41: track failure of rotation speed 40,42~50 : reserved			
F9-14	Time of the first error t	Reserved	1	*	●
F9-15	Information of the second error	0~50	1	*	●
F9-16	Time of the second error	Reserved	1	*	●

Code	Name	Setting range	Min. unit	Default	Operation
F9-17	Information of the third error	0~50	1	*	●
F9-18	Time of the third error	Reserved	1	*	●
F9-19	Information of the fourth error	0~50	1	*	●
F9-20	The fourth error time	Reserved	1	*	●
F9-21	Information of the fifth error	0~50	1	*	●
F9-22	Time of the fifth error	Reserved	1	*	●
F9-23	Information of the sixth error	0~50	1	*	●
F9-24	Time of the sixth error	Reserved	1	*	●
F9-25	Information of the seventh error	0~50	1	*	●
F9-26	Time of the seventh error	Reserved	1	*	●
F9-27	Information of the eighth error	0~50	1	*	●
F9-28	Time of the eighth error	Reserved	1	*	●
F9-29	Information of the ninth error	0~50	1	*	●
F9-30	Terminal input state 1 of the ninth error	0~65535	1	*	●
F9-31	Terminal input state 2 of the ninth error	0~65535	1	*	●
F9-32	Terminal output state of the ninth error	0~65535	1	*	●
F9-33	Fault frequency of	0.00Hz~99.00Hz	0.01Hz	*	●

Code	Name	Setting range	Min. unit	Default	Operation
	the ninth error				
F9-34	Fault current of the ninth error	0.0~99.99A	0.01A	*	●
F9-35	Bus voltage of the ninth error	0~999.9V	0.1V	*	●
F9-36	Month and day of the ninth error	Reserved	1	*	●
F9-37	Time of the ninth error	Reserved	1	*	●
F9-38	Information of the tenth error	0~50	1	*	●
F9-39	Terminal input state 1 of The tenth error	0~65535	1	*	●
F9-40	Terminal input state 2 of The tenth error	0~65535	1	*	●
F9-41	Terminal output state of The tenth error	0~65535	1	*	●
F9-42	Frequency of the tenth error	0.00Hz~99.00Hz	0.01Hz	*	●
F9-43	Current of the tenth error	0.0~99.99A	0.01A	*	●
F9-44	Bus voltage of the tenth error	0~999.9V	0.1V	*	●
F9-45	Month and day of the tenth error	Reserved	1	*	●
F9-46	Time of the tenth error	Reserved	1	*	●
F9-47	Information of the last error	0~50	1	*	●
F9-48	Terminal input state 1 of the last error	0~65535	1	*	●

Code	Name	Setting range	Min. unit	Default	Operation
F9-49	Terminal input state 2 of the last error	0~65535	1	*	●
F9-50	Output state of the last error terminal	0~65535	1	*	●
F9-51	Frequency of the last error	0.00Hz~99.00Hz	0.01Hz	*	●
F9-52	Current of the last error	0.0~99.99A	0.01A	*	●
F9-53	Bus voltage of the last error	0~999.9V	0.1V	*	●
F9-54	Month and day of last error	Reserved	1	*	●
F9-55	Time of last error	Reserved	1	*	●
FA Group Communication parameters					
FA-00	Baud rate setting	0 :300BPS 1 :600BPS 2 :1200BPS 3:2400BPS 4 :4800BPS 5 :9600BPS 6 :19200BPS 7 :38400BPS	1	5	★
FA-01	Data format	0 :No checkout :data format<8,N,2> 1:Even checkout :data format<8,E,1> 2 :Odd checkout :date format<8,O,1>	1	0	★
FA-02	Motor address	0~127, 0: broadcasting address	1	1	★
FA-03	Response delay	0~20ms	1ms	10ms	★
FA-04	Communication overtime	0.0 s(invalid), 0.1~60.0s	0.1s	0.0s	★

Code	Name	Setting range	Min. unit	Default	Operation
FB Group Elevator special function parameter					
FB-00	Delayed-time of speed-test	0.0~9.9S, 0: invalid	0.1S	5.0S	★
FB-01	Error range of speed-test mainframe	0~99%	1	30%	★
FB-02	Handrail speed step lose error range	0~99%	1	30%	★
FB-03	Rated pulse of host motor	0~200/S 0 :no detection	1	32	★
FB-04	Pulse interval of handrail speed	0.0~99.99s 0 :no detection	0.1S	0.00s	★
FB-05	Pulse interval of step loss	0.0~99.99s 0 :no detection	0.1S	0.00s	★
FB-06	Holding time of automatic-oil	0~999s	1s	72s	★
FB-07	Cycle time of automatic-oil	0~9999h	1h	167h	★
FB-08	Holding time of activate buzzer	1~99s	1s	5s	★
FB-09	Holding time of quick running	10~3000s	1s	40s	★
FB-10	Holding time of slow running	10~3000s	1s	40s	★
FB-11	Runtime of reversed entering	0~30s	1s	20s	★
FB-12	Assistant brake time	0.1~9.9S	0.1S	0.5S	★
FB-13	Brake-open detective time	0.5~9.9S	0.1S	1.5S	★
FB-14	Examine stop delayed-time	0~9.9S	0.1S	1.5S	★

Code	Name	Setting range	Min. unit	Default	Operation
FB-15	Oil mode selection	0~5	1	0	★
FB-16	Energy save mode selection	0 :invalid 1 :quick-stop cycle 2 :quick-slow cycle 3 :quick-slow-stop cycle	1	2	★
FB-17	Auto function selection	0 :half automatic mode running 1 :full automatic mode running	1	0	★
FB-18	Y-△ switch time	0~9.9s	0.1s	3.0s	★
FB-19	Safety arrester act mode	0 :invalid 1 :continuous working 2 :short-time working	1	0	★
FB-20	Safety brake act keep time	0~10s (electromagnet avail for short-time work)	1s	4s	★
FB-21	Comparison table of input and output	*	*	*	★
FF Group Factory parameters(reserved)					
FF-00	Factory password	Reserved			
FP Group User parameters					
FP-00	User password	0~65535 0 : no password	1	0	☆
FP-01	Parameter update	0 :null 1 :recover factory parameter 2 : clear memory information	1	0	★
FP-02	User setting inspect	0 :invalid 1 :avail	1	0	★



Instruction of function parameter

Chapter 6 Instruction of function parameter

6.1 F0 Group Basic parameter

F0-01	Driving mode	Default	1	Min. unit	1
	Setting range	0,1,2,3			

It can set the mode of running command and running speed of the system.

0: Operating panel control

Use the key “RUN” and “STOP” to control the machine, and the running speed is determined by F0-03 (running frequency of panel control). This running mode is mainly used for the debugging process of NICE2000.

When NICE2000 is in running, we have 3 ways to control the elevator:

1: Bypass conversion frequency drive

When in this mode, NICE2000 will automatically select variable frequency drive or work frequency drive according to the state of elevator (example: if there is any passenger). When no passenger is on the elevator, it will switch from work frequency to variable frequency; while having passengers, the elevator will accelerate, switching to work frequency.

2. Complete conversion frequency drive

In this mode, whether the running speed of the elevator is high or low, NICE2000 adopts variable frequency drive constantly. NICE2000 automatically control the speed according to the passenger state: no passenger, variable frequency at energy saving low running; while having passengers, variable frequency accelerate to high running.

3. Y-△ direct start

NICE2000 will use Y-△ to startup directly instead of variable frequency drive in this mode. When over-current fault happens, Y-△ can remain running normally.

F0-02	Frequency power setting	Default	0	Min. unit	1
	setting range	0			

0: interior figure setting

F0-03	Operating panel running frequency	Default	0.00Hz	Min. unit	0.01Hz
	setting range	0.00Hz~F0-04			

This function code is valid only when F0-01=0.

It sets up the initial default of speed when the elevator is controlled by panel operation. Once the value is set up, it can never be lost even when electric is cut off. User can change this function code to change the running speed.

F0-04	Max. frequency	50Hz	Depend on the model	Min. unit	0.01Hz
	setting range	50.00Hz~99.00Hz			

Set the max. output power of system.

F0-05	Carrier frequency	Default	Dependin g on the model	Min. unit	0.1KHz
	setting range	0.5~16.0kHz			

The magnitude of carry frequency is highly correlative to motor running. The carrier frequency generally is set upward10 KHz to travel without noise. It is suggested to reduce the carry frequency within noise allowing range.

When the carrier frequency is low, the output current higher-harmonic increases, and the consumption as well as elevated temperature of motor will increase.

When the carrier frequency is high, the consumption as well as elevated temperature of motor will decline, but the consumption, elevated temperature and interference of the system will all increase.

To regulate the carrier frequency will exert influences on the following performance:

Carrier frequency	low ~ high
Motor noise	large ~ small
Output current wave form	bad ~ good
Elevated temperature of motor	high ~ low
Elevated temperature of system	low ~ high
Leakage Current	small ~ large
External Radiation Interference	small ~ large

F0-06	Operating panel reverse running	default	0	Min. unit	1
	Setting range	0.1			

This function code can set the elevator running direction, but only when (F0-01=0) is valid. When function code value is 0, suppose the elevator runs up; when function code value is 1, suppose elevator runs down.

6.2 F1 Group Motor parameter

Function code	Name	Default	Min. unit	setting range
F1-01	Rated power	Depend on the model	0.1kW	2.2~75.0kW
F1-02	Rated voltage	380V	1V	0~440V
F1-03	Rated current	Depend on the model	0.01A	0.00~655.00A
F1-04	Rated frequency	50.00Hz	0.01Hz	0.00~99.00Hz
F1-05	Rated speed	960 rpm	1rpm	0~3000rpm

Please set according to the motor nameplate parameter.

It needs exact motor parameter to achieve good performance of NICE2000; parameter automatic distinguish is provided. Exact parameters distinguish function needs the right setting of the motor rating parameter.

Function code	Name	Default	Min. unit	Setting range
F1-06	Stator resistance	Depend on	0.001Ω	0.001~30.000Ω

Function code	Name	Default	Min. unit	Setting range
		the model		
F1-07	Rotor resistance	Depend on the model	0.001Ω	0.001~30.000Ω
F1-08	Leakage inductance	Depend on the model	0.01mH	0.01~300.00mH
F1-09	Mutual inductance	Depend on the model	0.1mH	0.1~3000.0mH
F1-10	No-load current	Depend on the model	0.01A	0.01~300.00A

To ensure the system performance, please collocate the machine according to the system standard. If the motor power is too much different from standard motor, it may lower the performance.

If the automatic tuning of the motor is completed normally, the setting values in F1-F6 to F1-F10 will update automatically.

If the motor tuning cannot be finalized automatically, refer to the congener motor with same parameter, and input the data by hand.

Note: Every change to the rated power F1-01, the system will recover parameter F1-06~F1-10 to default.

6.3 F2 Group Vector control parameter

F2-00	Frequency tracing responses speed	factory default 30	Min. unit	1
	Setting range	0-100		

The system will trace the frequency from the F6-02 when the motor switch from working freq.to variable freq. drive, and the tracing response speed is depend on F2-00, the recommended value of F6-02 is 50 Hz,and the parameter is set among 20-50.

Note: frequency tracing will stay at F6-02 when the parameter was set as 0,and until the tracing is ok.(same as the original way)

F2-01	Freq.tracing constant speed delay time	Factory default	0.60s	Min.unit	0.01
	Setting range	0.01-10.00s			

When the escalator switch from the work freq.to variable freq., it will run with the constant freq.as tracing .The motor will run at decrease freq. after the F2-01 setting time.this parameter needs no modification.

Function code	Name	Default	Min. unit	Setting range	
F2-02	Switching frequency 1	2.00Hz	0.01Hz	0.00~F2-05Hz	
F2-03	Proportional gain of speed loop 2	30	1	0~100	
F2-04	Integration time of speed loop 2	0.80s	0.01s	0.01~10.00s	
F2-05	Switching frequency 2	5.00Hz	0.01Hz	F2-02~F0-04Hz	
F2-06	Freq. tracing current setting	Default	100%	Min. unit	1%
	setting range	50~130%			

The system will trace the freq. with the current of F2-06. This parameter needs no modification.

F2-07	Filter coefficient of speed loop	Default	0.00s	Min. unit	0.01s
	setting range	0.00~5.00s			

This function code is the filter time of ASR output (torque current), current sampling and speed feedback. Generally speaking, we don't need to adjust the parameter; when there is strong interference, just add time constant.

The output of speed regulator refers to the torque current command to the controller. The filter time constant of speed loop refers to the filter time of the torque current command.

When the constant is big, the inverter torque becomes smooth, but the response becomes slow. Vice versa.

F2-08	Upper limit of torque	Default	150.0%	Min. unit	0.1%
	setting range	0.0~200.0%			

It can set upper limit of torque of motor. 100% corresponds to the rated torque of the motor that matches the system.

6.4 F3 Group Motor control parameter

F3-00	Torque hoist	Default	1.0%	Min. unit	0.1%
	setting range	0.0(automatic), 0.1%~30.0%			
F3-01	Torque hoist frequency	Default	50.00Hz	Min. unit	0.01Hz
	setting range	0.00~Max.freq.			

In order to compensate the V/F control low frequency torque characteristic, some lifting compensation of the inverter output current are added.

If torque hoist is set too large, it may cause over-heated motor and over-current inverter. Normally, do not set torque lifting over 10%.

To adjust this parameter effectively can avoid over-current at startup of motor. As to the situation of over-load, it is recommended to increase this parameter; vice versa.

When the torque hoist is set to 0, inverter becomes automatic torque rising.

With regard to the torque hoist frequency, if the setting is within the frequency range, the torque is valid; while if the setting is beyond the frequency range, the torque hoist is invalid.

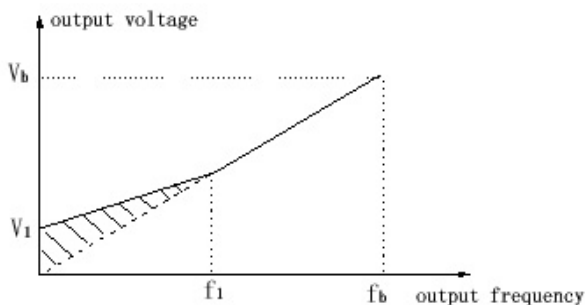

V_1 : hand torque rise voltage V_b :max output frequency
 f_1 : torque rise shut off frequency f_b :basic running frequency

Fig 6-3 Hand-operated torque hoist

F3-02	Slip compensation	Default	0.0%	Min. unit	0.1%
	setting range	0.0%~200.0%			
F3-03	AVR select	Default	1	Min. unit	2
	setting range	0, 1, 2			
F3-04	oscillating restrain gain	Default	0	Min. unit	1
	setting range	0~100			

F3-02 Slip compensation is effective for V/F control. To set this parameter can compensate the slip load when it is V/F controlled, minishing the change of motor rotation generated due to the variation of the load; generally, 100% corresponds to rated slip when the motor with rated load. We can adjust slip coefficient referring to following principle: when slip compensate coefficient is set up to 100% with rated load, the rotation of the inverter motor is basically close to given speed. If with lower load, this coefficient can be less than 100%; and if with lager load, this coefficient can also be larger than 100%.

F3-03 AVR (automatic steady voltage function) select. In the V/F control mode, when need quick stop but without brake resistance, selecting 2 “only valid when decelerated” can greatly reduce the possibility of the over voltage fault alarm; but at the circs of having brake resistance or quick decelerate unnecessary, please select 1 “whole process valid”.

F3-04 oscillating restrain gain, when motor has no oscillating phenomena, please select the parameter to 0. Only when motor have obvious oscillating

and cannot run normally, propriety increase of this function can restrain the surge efficiently. Setting method of the parameter: choose as small as possible amount at the premise of effective restrain the motor oscillating.

6.5 F4 Group Input function parameter

F4-00	Input filter time	Default	4	Min. unit	1
	setting range	1~10			

Set sensitivity of the input terminal. If digit input terminal is liable to suffer interference then arose malfunction, to raise the parameter will enhance anti-jamming capacity, but meanwhile it will decrease sensitivity of the input terminal.

Function code	Name	Default	Min. unit	Setting range
F4-01	X 01 terminal selection	26	1	0~46
F4-02	X 02 terminal selection	3	1	0~46
F4-03	X 03 terminal selection	4	1	0~46
F4-04	X 04 terminal selection	30	1	0~46
F4-05	X 05 terminal selection	1	1	0~46
F4-06	X 06 terminal selection	31	1	0~46
F4-07	X 07 terminal selection	33	1	0~46
F4-08	X 08 terminal selection	8	1	0~46
F4-09	X 09 terminal selection	19	1	0~46
F4-10	X 10 terminal selection	15	1	0~46
F4-11	X 11 terminal	16	1	0~46

	selection			
F4-12	X 12 terminal selection	12	1	0~46
F4-13	X 13 terminal selection	18	1	0~46
F4-14	X 14 terminal selection	17	1	0~46
F4-15	DI 1 terminal selection	13	1	0~46
F4-16	DI 2 terminal selection	14	1	0~46
F4-17	DI 3 terminal selection	10	1	0~46
F4-18	DI 4 terminal selection	11	1	0~46
F4-19	DI 5 terminal selection	5	1	0~46

X01~X14, DI1~DI5 are switch input terminals, and they can select corresponding function codes 00~46, the same function code cannot be used repeatedly.

Every function has corresponding code. The code of every function is as follows:

00 No function:

The controller does not work even if the signal is input. Set the unused terminals as none to prevent error work.

01 N.O. input of safety circuit signal

It is an important guarantee of lift safety running, including a lot of safety switch device. Any fault happened to safety circuit will cause to the elevator's direct stop. So it is a necessary condition of elevator running.

02 N.O. input of inspect signal 03 N.O. input of up motion 04 N.O. input of down motion

Insert examine handle into examine interface of upper/ down machine room, and elevator will come to examine state. When examine signal is input to the NICE2000 system, the system will cancel whole normal running into examine

circs. When having examine up signal or examine down signal input to the system, elevator is running with examine speed.

05 N.O. input of host motor test speed signal

For the sake of elevator safety, we need monitor the motor running speed. When host motor test speed pulse shows abnormality, NICE2000 will protect it; consequently ensure the elevator safety. After this signal receives sensor signal which is transmitted by the motor, it will judge the speed of operation.

06 N.O. input of contact conglutination signal

Monitor the overall work contactor to avoid the elevator's next running when any of the contactors has conglutination fault.

07 N.O. input of drive chain detect

Drive chain's rupture will directly threaten the running safety of the elevator, and it is also one of the important conditions of additional safety arrester brake work. NICE2000 controller judges drive chain abnormality or not according to this input.

08 N.O. input of brake detection

Open or close work arrester (brake) will directly influence the normal work. To avoid motor running with brake, the detection is necessary.

09 N.O. input of non-reversion detect

In order to avoid non-operate reverse protection, the test can effectively avoid the situation of up process reverse to downgrade, but it doesn't need to consider in the state of downgrade.

10 N.O. input of up photo electricity

11 N.O. input of down photo electricity

12 N.O. input of energy save selection

Energy save switch is used to set the elevator state (at hand or automatic). At the state of automatic energy save, up-down photoelectricity detect switch can monitor the passengers. NICE2000 dispose automatic energy save running through these two signals.

Energy save selection valid indicates that the controller is in the automatic running state.

13 N.O. input of left handrail speed

14 N.O. input of right handrail speed

The running speed of the left/right armrest strap is separately monitored, to avoid the elevator stop running when the armrest appear abnormality and output

alarm.

15 N.O. input of up step loss 16 N.O. input of down step loss

Up/down step of the running process is separately monitored, to avoid the elevator stop running when the step loss, and output alarm.

17 N.O. input of variable frequency speed selection

When the elevator needs diverse speed, the signal can adjust the speed selection by hand (only the quick running state). When this signal is valid, the quick frequency of NICE2000 is the setting parameter of quick 2 frequency. This function is valid both in the bypass variable frequency and complete variable frequency.

18 N.O. input of driving mode selection

This signal can select elevator Y- Δ circs running with high PRI, when the signal is effective, even if F0-01set up to bypass variable frequency or complete variable frequency, NICE2000 will come into elevator Y- Δ circs running.

19 N.O. input of fire signal

When have fire alarm, this signal can cut off lift running signal.

20 N.O. input of fault reset

External fault reset terminal signal.

21 N.O. input of stop signal

The signal available indicates lift in the stop state, as well as NICE2000.

22 N.O. input of normal parallel connection

When NICE2000 is used to connect in parallel, it needs to identify if the external signal of NICE2000 normal or not. Only when both controllers are in normal state, can we make parallel connection.

Options 25~46

They are the N.C. signal points of the above mentioned options with same functions.

F4-22	Safety brake delaying time	default	500ms	Min. unit 1ms
	Setting range 0- 65535ms			

The escalator will output safety brake after this parameter set time when the drive chain broken or over-speed and reversion error occur.

F4-23	Frequency tracing error auto reposition time	default	3	Min unit	1s
	Setting range	1-10			

When the Em02-Em07 errors occur, the system will restored and run with low car speed after this parameter set time. This parameter is valid only when the bit 5 of F4-27 is 1.

F4-24	Frequency tracing time limit	default	10s	Min unit	1s
	Setting range	1-20			

This parameter is valid only when the BIT 5 of F4-27 (escalator auxiliary function selection) is 1.

Function code	Name	Default	Min. unit	Setting range
F4-25	Time multiply of first running	5	1	0~20

When the controller key is start up, the elevator need some time to switch from high speed to low speed. If the running time is over the above time (FB-09* F4-25) with no passengers, it will turn to low speed running.

Function code	Name	Default	Min. unit	Setting range
F4-26	Ai apex value selection	1350	1	1200~1600

The relative parameter of in-phase switching card of elevator; when in high speed running, it is a judge condition of the switching. The setting amount cannot exceed the actual input of Ai apex, or the judge may not be precise so that the switch will overstep the F4-28 time limit then forced to switch. If no obvious improvement happens after the debugging experts adjust F8-13 and F8-14, minish the parameter with the amount of 30 every time.

F4-27	Assistant function selection	Default	21	Min. unit 1
	Setting range	0~65535		

Bit 5, Bit 7 are the new added, and the default 21 is corresponding to Bit 0, Bit 2, Bit 4 valid.

BIT0

0: The inverted photoelectricity doesn't work, which means the elevator will not accelerate in case of passenger entering in reversed direction in decelerating process or low speed climbing.

1: The elevator will accelerate to high speed running, when there are passengers entering in reversed direction.

Bit 1

Set as 0: high speed startup, after key switch action, escalator reach high speed running state.

Set as 1: low speed startup ,after key switch action, escalator reach low speed running state.

BIT2

0: Monitor the mainframe both in high speed running and low speed running.

1: Monitor the mainframe only in high speed running.

BIT3

0: Alarm only once when having fault.

1: Impulse alarm when having fault.

BIT4

0: Alarm at once, when having fault.

1: Alarm only when having successive faults.

Bit 5

0: if the system can not trace the frequency after 15s, E41 tracing error reported.

1: Err01- Err 07 occur, the system will restored and startup with slow car speed after F4-23's setting time. If no such errors, there is no frequency tracing anymore and system turn to slow car startup.

Bit 6 reserved

Bit 7

0: reversion judgment through reversion switch.

1: reversion judgment through 2 photoelectricity signals A and B, WIRING :A connected to D15 terminal and B connected to D11 terminal . Function selection of D11 (F4-15) needs no settings.

Bit 8

0: up/down command need only touching off signal

1: the up/down signal should be valid all along, the system will stop running when the key startup signal is invalid.

Bit 9

0: the original mode

1: the new switching software is start (F8-13,14 invalid, only related to FC-00-FC-05)

BIT 10

0: armrest band lag judgment only

1: select armrest signal to judge over-speed and lag.

Function code	Name	Default	Min. unit	Setting range
F4-28	Max. delayed-time for synchronous switch	3.000s	0.001s	2.000~10.000s

When variable frequency switching to the work frequency, record time after F4-29 has made delayed-time stable. If the proper condition never exists within F4-28 time limit, it will be forced to work frequency. Generally speaking, this parameter is adjusting-free

Function code	Name	Default	Min. unit	Setting range
F4-29	Stable speed delayed-time for synchronous switch	0.500s	0.001s	0~2.000s

When the variable frequency switching to rated stable state (factory default is 51.5 Hz), and after the time set by this function code, considering it has stable speed, then judge the switch condition. Generally speaking, this parameter is adjusting-free.

Function code	Name	Default	Min. unit	Setting range
F4-30	Filter times of synchronous card analogue sampling	1	0.001s	0~9

This parameter multiplying 2 equals to the filter time (unit: Ms), in order to

enhance the interference proof capacity. Generally speaking, this parameter is adjusting-free..

6.6 F5 Group Output function parameter

Function code	Name	Default	Min. unit	Setting range
F5-00	D0 output selection	0	1	00~17
F5-01	Y1 function selection	2	1	00~17
F5-02	Y2 function selection	3	1	00~17
F5-03	Y3 function selection	4	1	00~17
F5-04	Y4 function selection	5	1	00~17
F5-05	Y5 function selection	1	1	00~17
F5-06	Y6 function selection	6	1	00~17
F5-07	Y7 function selection	7	1	00~17
F5-08	Y8 function selection	12	1	00~17
F5-09	Y9 function selection	11	1	00~17
F5-10	Y10 function selection	9	1	00~17
F5-11	Y11 function selection	10	1	00~17
F5-12	Y12 function selection	8	1	00~17

DO1 is digit output terminal, and the interface is open circuit collector mode; Y1~Y12 are relay output terminals, and among them Y1~Y11 are relay output terminals of the expand I/O control board of NICE2000; and Y12 is main control board relay output. These output terminals can select corresponding function code 1~17. Each function is denoted by its code:

00 No function

To set unused terminal with no function can avoid unintended action.

01 Running contactor

Used for the contactor of inverter's output side.

02 up contactor 03 down contactor

During the work frequency running (unconverted frequency running), up/down contactor can control the running direction of the elevator.

04 Y running contactor 05 Δ running contactor

When use six level motor, Y/ Δ contactor is used for motor wiring control.

Δ contactor applies to double speed bypass variable frequency system and

standby Y-△ system. While the Y contactor is only suitable for Y-△ system.

06 Brake contactor output

Brake output contactor can release the arrester of motor; thereby it allows the motor operation.

07 Assistant brake contactor

This function supplies strong signal of the brake contactor.

08 Security brake contactor

When the height of escalator is raised ($H > 6m$), additional safety arrester should be outfitted. When facing the situation of drive chain rupture or anti-reverse switch act, the elevator will begin reversion or run exceeding 1.3 times of rated speed, then the security arrester act.

09 Up direction indicate output

10 Down direction indicate output

They are used for direction indicator; with it, passengers can identify direction when they are hitching escalator.

11 Buzzer output

In the case of escalator startup, fault or having reverse passenger, buzzer is playing an important role.

12 Oil output

Oil output controls lubricate pump, and can oil the controller automatically or by hand.

13 Fault output

It is valid when NICE2000 has error.

14 Integrative preparation ready

When the controller is well prepared, the relay is in N.C. output state; while when the power supply is cut off or error happens, the relay is in N.O. output state.

15 Start-up contactor

When the lift is running, the output will start up the connector. In the other hand, when elevator stops, it will cut off the exported.

16 Rapido running state output

When the elevator is in variable frequency or Δ running state, this signal will be output.

17 Slow running state output

When the escalator is accelerating, decelerating or slow climbing, or in examine, this signal is exported.

Function code	Name	Default	Min. unit	Setting range
F5-16	Output mode selection	65535	1	0~65535

Output mode selection is used to set the type of every output point, whether N.O. or N.C.

0: N.C. output 1:N.O. output

Bit0	Unused	Bit7	Assistant brake contactor output
Bit1	Running contactor output	Bit8	Safety brake contactor output
Bit2	Up(NET) contactor output	Bit9	Up direction output
Bit3	Down (NET) contactor output	Bit10	Down direction output
Bit4	Y-type running contactor output	Bit11	Buzzer output
Bit5	△type running contactor output	Bit12	Oil output
Bit6	Brake contactor output	Bit13	Fault output

F5-17	A0 bias	0.0%	0.1%	
F5-18	A0 gain	1.00	0.01	
F5-19	A0 output selection	0	1	00~55

If bias is represented by “b”, gain by “k”, actual output by “Y”, standard output by “X”, and then actual output is:

$$Y=kX+b;$$

100%AO bias coefficient is corresponded to 10V (20mA).

The standardized output is within 0~10V (20mA), corresponding simulate quantity 0~max.

It is generally used to modify simulate output zero-float and windage of output breadth. It can also be any needed output curve which is user-defined.

For example: if simulate output content is running frequency, and want to export 8V (16mA) when frequency is 0, and export 3V (6mA) when frequency is max; then we need to set gain to “-0.50” and set bias to “80%”.

6.7 F6 Group Elevator basic parameters

Function code	Name	Default	Min. unit	Setting range
F6-00	Switch variable frequency to work frequency	0.2s	0.1s	0~2.0s

This parameter is only used in bypass variable frequency. When variable frequency accelerates to stable speed, after the time set by F6-00, it will switch to work frequency.

Function code	Name	Default	Min. unit	Setting range
F6-01	Switch work frequency to variable frequency time	0.2s	0.1s	0~2.0s

This function code is only used in the bypass variable frequency control situation, with similar function of F6-00. When NICE2000 is at start of energy save run, in work frequency and variable frequency switch control process, export the switch time of output contactor. Generally these two parameters are set about 0.2s.

Function code	Name	Default	Min. unit	Setting range
F6-02	Switch variable frequency to frequency	43.0Hz	0.1Hz	0~50.0Hz

This function code is only used in the bypass variable frequency control situation. When elevator starts to run in energy-save mode, deviate work frequency control,

When the F2-00 is non-zero ,the system will trace down from the set frequency, and will be variable freq. driven after the tracing is finished, the motor sill run at constant speed ,this parameter is generally adjusting-free.

When the F2-00 is zero, the system will trace at the set freq. place. The motor will run at constant speed after the tracing finished.

Function code	Name	Default	Min. unit	Setting range
F6-03	Quick 1 running frequency	50	0.01Hz	0~Max. frequency
F6-04	Quick 2 running frequency	30	0.01Hz	0~F6-03
F6-05	Slow running frequency	20	0.01Hz	0.00~F6-04

F6-03 and F6-05 are valid both in the control of bypass variable frequency and complete variable frequency. F6-04 is suitable for complete variable frequency, and can satisfy the demand of traditional speed complete variable frequency system.

Generally speaking, parameter of quick 1 frequency is set to work frequency, and parameter of quick 2 frequency is another standby option. In the complete variable control mode, if input terminal function “convert speed selection” is valid, NICE2000 will adopt quick 2 running frequency for quick aim frequency; if “convert speed selection” is invalid, NICE2000 will adopt quick 1 frequency for quick aim frequency. Quick aim frequency of the bypass variable frequency is also selected according to this principle; but generally in the bypass convert frequency, quick aim frequency only have one, so at this mode, have no use for this function.

When the elevator running at convert frequency energy save mode with no passenger, elevator will enter slow wait running, at this moment slow running aim frequency is F6-05.

Function code	Name	Default	Min. unit	Setting range
F6-06	Star -Δ switch delayed-time	100Ms	1Ms	0~50Ms

When the controller is in star- Δ mode, after FB-18 startup time, the star contactor is released, and then after F6-06 switching time, export Δ contactor.

Function code	Name	Default	Min. unit	Setting range
F6-07	Accelerate time	4.0s	0. 1s	0.0~3000.0s
F6-08	Decelerate time	20.0s	0. 1s	0.0~3000.0s

Accelerate time is the time needed from zero speedup to Max. frequency
Decelerate time is the time needed from Max. frequency decelerate to zero.

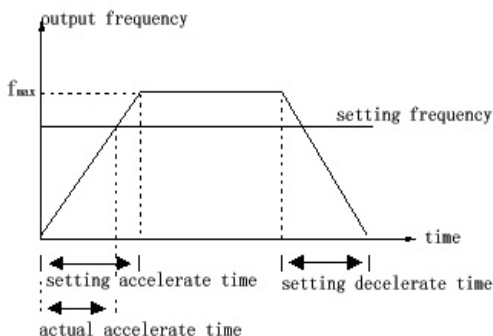

Refer to next fig 6-4:

Fig 6-4 Accelerate and decelerate time

When set frequency equals to max.output frequency, actual accelerate/decelerate time is the given accelerate/decelerate time.

When set frequency is less than max. output frequency, actual accelerate time =set value \times (set frequency /max.frequency).

Function code	Name	Default	Min. unit	Setting range
F6-09	Inspection frequency	25.0Hz	0.01Hz	0~Max.frequency
F6-10	Inching (examine and repair) accelerate time	20.0	0. 1s	0.0~3000.0s

Examine frequency is the aim frequency of examine running. At accelerate examining process, use F6-10:

1. Inching (examine) accelerate time is the time needed from zero to max.frequency.
2. If examine aim frequency is less than Max.frequency, actual accelerate time = $F6-10 \times (\text{examine frequency} / \text{max.frequency})$.

Function code	Name	Default	Min. unit	setting range
F6-11	Inspection mode selection	0	1	0~1

This Function code sets the inspection running mode.

1: Y type running 0: Determined by F0-01(escalator driving mode)

Function code	Name	Default	Min. unit	setting range
F6-12	Up-frequency switch surplus	1.5Hz	0.01Hz	0~10.00Hz
F6-13	Down-frequency switch surplus	1.5Hz	0.01Hz	0~10.00Hz

They are assistant parameters of up/down frequency switches. If after adjustment of F8-13 and F8-14, the switch effect is not obvious and elevator is running with strong mechanical friction, user should increase this parameter group in a slight extent.

6.8 F7 Group Assistant function parameter

F7-00	Running parameter display	Default	16383	Min. unit	1
	Setting range	1~16383			

F7-00 can control the display of 14 running parameters, and each parameter is controlled by a binary code (1: display this parameter, 0: don't display this parameter. For example: if F7-00 is set to 8191, the elevator can monitor 13 parameter states through shift key on operating panel.

Bit0: running frequency

Bit2: DC bus voltage

Bit1: aim frequency

Bit3: output voltage

Bit4: output current

Bit5: AI1

Bit6: AI2

Bit7: low bit of input state

Bit8: high bit of input state

Bit9: output state

Bit10: pulse number of host motor

Bit11: time interval of handrail speed test

Bit12: time interval of step loss

Bit13: input/output state

NICE2000 uses the shift key “»” to display the above parameters one by one in running process.

F7-01	Parameter display in stop	Default	255	Min. unit	1
	Setting range	1~255			

This function can control the display of 8 parameters in stop state and each parameter is controlled by one bit binary code (1: display this parameter, 0 don't display this parameter). For example: if F7-01 is set to 15, the elevator can monitor 4 kinds of parameter state through shift key on operating panel.

Bit0: aim frequency

Bit1: DC bus voltage

Bit2: AI1

Bit3: AI2

Bit4: pulse number of host motor

Bit5: time interval of handrail speed test

Bit6: time interval of step loss

Bit7: input/ output state

F7-02	Running time setting	Default	0	Min. unit	1
	Setting range	0~60000			

When the accumulated work time exceeds setting value of F7-02, elevator will follow the work mode set by F7-05. If F7-02 parameter is set to 0, this function will be invalid.

F7-03	Accumulative working hours	Default	0	Min. unit	1
	Setting range	0~65535			

It reflects the elevator's actual running time, and this function is read only parameter so that user cannot modify.

F7-05	Runtime to act selection	Default	0	Min. unit	1
--------------	---------------------------------	---------	---	-----------	---

	Setting range	0, 1
--	----------------------	------

This function code defines the elevator's running state when the runtime has reached the time set by F7-02.

0: continue to run

1: stop

F7-06	Electrify to ground short protect detection	Default t	1	Min. unit	1
	Setting range	0, 1			

This function code can determine if elevator control system has grounding short fault when detect motor after electrifying. If this function is valid, then elevator will begin detection when electrifying instantly; if the system has grounding short fault, it will close off output at once, and export Err 23.

0: forbid

1: permit

F7-07	Brake use rate	Default t	1%	Min. unit	0
	Setting range	0~100%			

When under complete convert frequency mode, if elevator runs downgrade, motor will have energy feedback, leading to bus voltage hoist. Here, the system needs to collocate brake resistance; F7-07 can adjust brake effect of the brake unit.

Function code	Name	Setting range	Default	Min. unit
F7-08	Software edition 1	00.00~999.99	00.00	0.01
F7-09	Software edition 2	00.00~999.99	00.00	0.01
F7-10	Radiator temperature	0~100℃	0	1℃

F7-08 and F7-09 display the software number used in the integrity.

F7-10 displays the radiator's temperature.

Function code	Name	Default	Min. unit	Setting range
F7-11	Terminal input state display	*	*	*
F7-12	Terminal output state display	*	*	*

F7-11 and F7-12 are used to inspect the input and output state of elevator control system.

NICE2000 elevator control system operating panel has 5 LED display, from right to left separately is LED4, LED3, LED2, LED1, LED0 (light on: valid signal)

Terminal input state (F7-11) is defined as follows:

LED0	A: Safety loop signal	LED1	A: Brake inspection	LED2	A: Up step lost
	B: Repair signal		B: Non-reversion inspection		B: Down step lost
	C: Up motion		C: Up photoelectricity		C: Speed selection of variable frequency
	D: Down motion		D: Down photoelectricity		D: driving mode selection
	E: Speed test of mainframe		E: Energy save selection		E: Fire reset
	F: Contactor conglutination		F: Left handrail speed		F: Fault reset
	G: Driving chain		G: Right handrail speed		G: Stop signal

Terminal output state (F7-12) is defined as follows:

LED0	A: Running contactor	LED1	A: Safety inspection	
	B: Up contactor		B: Non-reversion inspection	
	C: Down contactor		C: Up photoelectricity	
	D: Y running contactor		D: Down photoelectricity	
	E: Δ running contactor		E: Energy save selection	
	F: Brake output contactor		F: Left handrail speed	
	G: Assistant brake contactor		G: Right handrail speed	

6.9 F9 Group Assistant management parameter

Function code	Name	Default	Min. unit	Setting range
F8-13	Switch coefficient of up in-phase	6	1	13
F8-14	Switch coefficient of down in-phase	6	1	13

When in bypass convert frequency control, due to the sudden brake of voltage happened in the switching from convert frequency to work frequency, the elevator may shake with unstable speed. F8-13 and F8-14 are aiming to eliminate this phenomenon.

F8-13 and F8-14 are only valid in bypass convert frequency, and cannot work without NICE2000 in-phase switch card. When F8-13=0, F8-14=0, this function is invalid. If parameter is set at the range of 1~13, it denotes the different switch mode of NICE2000. In the debugging process, change the parameter in turn; if the setting is appropriate, it can come to the calmest switch.

Change to F6-00 parameter or periphery contactor act time will influence the setting of the F8-13 and F8-14, so the debugging process must conduct as: 1) first set F6-00=0; 2) debug F8-13 and F8-14, rectifying from large to small until feel the transition smoothly. If basically can feel the shake every time, minish F4-26 parameter (decrease 30 every time) until the shake is eliminated.

6.10 F9 Group Protection function parameter

F9-00	Overload protect selection	Default	1	Min. unit	1
	Setting range	0, 1			

0: The system has no over-load protection.

1: The system has over-load protection. Refer to F9-01.

F9-01	Overload protect coefficient	Default	1.00	Min. unit	0.01
	Setting range	0.50~10.00			

The reference of this function code is over-loaded current. When system has detected the output current reaching to $F9-01 \times$ motor rated current and last to the end of anti-time limit curve fixed time, it will export Err 11.

F9-03	Over voltage lose speed gain	0	1	0(non over voltage lose speed)~100
F9-04	Over voltage lose speed point	130%	1%	120~150%
F9-05	Over current lose speed gain	20	1	0~100
F9-06	Over current lose speed point	150%	1%	100~200%

Over voltage lose speed gain:

It can adjust inverter's ability to restrain over-voltage lose speed. The value of this parameter and the ability is in direct ratio.

For small inertia load, the value should be small; otherwise the system dynamic will become slow accordingly.

For big inertia load, the value should be large; otherwise it will influence the restrain effect, and may cause over-voltage fault.

Over voltage lose speed point:

It can select function protection point of the over voltage lose speed. The inverter will start to perform over-voltage lose speed protection when exceeding this value.

Over current lose speed gain:

It can adjust inverter's restrain over-current lose speed ability. The value of this parameter and the ability is in direct ratio.

For small inertia load, the value should be small; otherwise the system dynamic will become slow accordingly.

For big inertia load, the value should be large; otherwise it will influence the restrain effect, and may cause over0current fault.

Over current lose speed point:

It can select function protection point of the over current lose speed. The inverter will start to perform over-current lose speed protection when exceeding this value.

Function code	Name	Default	Min. unit	Setting range
F9-07	Non-stop of Instant stop function	0	1	0~1
F9-08	Decline frequency rate of non-stop of instant stop	10.00Hz/s	0.01Hz/s	0.00Hz/s~ Max. frequency/s

Non-stop of Instant stop function:

This function indicates that the inverter will not stop when power is cut off instantly. Under the situation of instant power off or sudden reduced voltage, the inverter's output speed will slowdown, so that compensate the reduced voltage through load feedback energy. It can make inverter continue to run in short time.

Decline frequency rate of non-stop of instant stop:

It is used to set drop value of the inverter output frequency.

If the value as well as the load feedback energy is too small, low voltage compensate can't be carried out.

If the value as well as the load feedback energy is too large, over voltage protection cannot be achieved.

Please adjust this parameter appropriately according to the load inertia.

F9-09	Fault reset times	Default	0	Min. unit	1
	Setting range	0~3			

When system selects automatic fault reset, it is used to set the time of automatic reset. The system will wait for resetting if exceeding this value.

0: no automatic reset function

F9-10	Fault reset interval	Default	1.0s	Min. unit	0.1s
	Setting range	0.1~100.0s			

It is the waiting time from fault alarm to automatic reset of the system.

F9-11	Input phase loss	Default	1	Min. unit	1
	Setting range	0~1			

0: Forbid 1: Permit

Select if protection to the input phase loss situation is allowed. (Only for model above 7.5KW)

F9-12	Output phase loss	Default	1	Min. unit	1
	Setting range	0~1			

0: Forbid 1: Permit

Select if protection to the output phase loss situation is allowed.

Function code	Name	Default	Min. unit	Setting range
F9-13	The first error information	0	1	0~50
F9-14	Reversed	0	1	0~1231

Function code	Name	Default	Min. unit	Setting range
F9-15	The second error information	0	1	0~50
F9-16	Reversed	0	1	0~1231
F9-17	The third error information	0	1	0~50
F9-18	Reversed	0	1	0~1231
F9-19	The fourth error information	0	1	0~50
F9-20	Reversed	0	1	0~1231
F9-21	The fifth error information	0	1	0~50
F9-22	Reversed	0	1	0~1231
F9-23	The sixth error information	0	1	0~50
F9-24	Reversed	0	1	0~1231
F9-25	The seventh error information	0	1	0~50
F9-26	Reversed	0	1	0~1231
F9-27	The eighth error information	0	1	0~50
F9-28	Reversed	0	1	0~1231
F9-29	The ninth error information	0	1	0~50
F9-30	The ninth error terminal input state 1	0	1	0~65535
F9-31	The ninth error terminal input state 2	0	1	0~65535
F9-32	The ninth error terminal output state	0	1	0~65535
F9-33	The ninth error fault frequency	0.000	0.01 Hz	0.00Hz~99.00Hz
F9-34	The ninth error fault current	0.00	0.01A	0.0~99.99A
F9-35	The ninth error bus voltage	0	0.1V	0~999.9V
F9-36	Reversed	0	1	0~1231
F9-37	Reversed	0	1	0~2359
F9-38	The tenth error information	0	1	0~50
F9-39	The tenth error terminal input state 1	0	1	0~65535
F9-40	The tenth error terminal input	0	1	0~65535

Function code	Name	Default	Min. unit	Setting range
	state 2			
F9-41	The tenth error terminal output state	0	1	0~65535
F9-42	The tenth error fault frequency	0.000	0.01 Hz	0.00Hz~99.00Hz
F9-43	The tenth error fault current	0.0	0.01A	0.0~99.99A
F9-44	The tenth error bus voltage	0	0.1V	0~999.9V
F9-45	Reversed	0	1	0~1231
F9-46	Reversed	0	1	0~2359
F9-47	The last error information	0	1	0~50
F9-48	The last error terminal input state 1	0	1	0~65535
F9-49	The last error terminal input state 2	0	1	0~65535
F9-50	The last error terminal output state	0	1	0~65535
F9-51	Last error fault frequency	0.000	0.01 Hz	0.00Hz~99.00Hz
F9-52	The last error fault current	0.00	0.01A	0.0~99.99A
F9-53	Error bus voltage	0	0.1V	0~999.9V
F9-54	Reversed	0	1	0~1231
F9-55	Reversed	0	1	0~2359

This group parameter can record the latest 11 fault information and fault occurring time. Fault information displays fault code. As to the detailed type and their significations, please refer to chapter 8.

6.11 FA Group Communication parameter

Refer to 《NICE2000 Communication Protocol》

6.12 FB Group Elevator special function setting

Function code	Name	Default	Min. unit	Setting range
FB-00	Speed detect delay	5.0s	0.1s	0~9.9S

After NICE2000 control system has power on, host motor pulse/ step loss pulse/ handrail pulse should be monitored in order to discover the hidden safety trouble so that ensure the normal running of elevator.

When NICE2000 control system begins to run every time, it will first pass the time defined by FB-00, and then starts to detect relative mainframe speed test/ step loss/ armrest speed test.

If FB-00 = 0.0, NICE2000 will not monitor the pulse signal.

Function code	Name	Default	Min. unit	Setting range
FB-01	Error range of host motor speed test	30%	20%	20~99%
FB-02	Error range of armrest speed, step loss	30%	20%	20~99%

These two function codes reflect the error range of host motor speed test and armed speed/ step loss, and respectively work together with FB-03 and FB-04. Suppose FB-01 is set to 30% and FB-03 is 32, the system will alarm if detecting 23~41 pulses per second; otherwise it will not give alarm.

Function code	Name	Default	Min. unit	Setting range
FB-03	Host motor rated pulse	32	1	0~200/S

FB-03 has defined the pulse number per second when the elevator is running in rated rotate speed. Via this function code, NICE2000 judges if the mainframe is running in normal state. It is normal if the output pulse number is within 20% of setting range; or it will arouse the alarm.

If FB-03=0, NICE2000 will not do the mainframe pulse signal test.

If the machine reaches high speed running in bypass convert frequency mode, user can inquire about host motor's impulse number every second by the shift key ">>".

Function code	Name	Default	Min. unit	Setting range
FB-04	Handrail speed pulse interval	0.0s	0.1s	0.0~99.99s

NICE2000 is carrying though handrail speed impulse test according to FB-04. If the interval is more than setting time, it may arouse the alarm. And the corresponding time of FB-04 is the handrail speed impulse interval when elevator is running in rated speed.

If FB-04=0, NICE2000 will not do the handrail pulse signal test.

If the machine reaches high speed running in bypass convert frequency mode, user can inquire about handrail's impulse interval by the shift key ">>".

Function code	Name	Default	Min. unit	Setting range
FB-05	Step lose pulse interval	0.00s	0.1s	0.0~99.99s

Similar to handrail speed pulse interval, NICE2000 is carrying through step loss pulse interval according to FB-05. If the interval is more than setting time, it may arouse the alarm. And the corresponding time of FB-05 is the step pulse interval when elevator is running in rated speed.

If FB-05=0, NICE2000 will not do the step loss pulse signal test.

If the machine reaches high speed running in bypass convert frequency mode, user can inquire about step's impulse interval by the shift key ">>".

Function code	Name	Default	Min. unit	Setting range
FB-06	Holding time of automatic-oil	72s	1s	0~999s
FB-07	Cycle time of automatic-oil	167h	1h	0~9999h

With automatic oil function, NICE2000 will carry through oil output when accumulative runtime exceeding setting time of FB-07; at this time, "oil output" signal is valid, and will disappear after the time of FB-06.

This function code defines the holding time of automatic oil and time interval between two automatic oil.

Function code	Name	Default	Min. unit	Setting range
FB-08	Holding time of startup buzzer	5s	1s	1~99s

NICE2000 will carry through buzzer output when the direction is switching every time, and the holding time of the buzzer prompt is determined by parameter of FB-08.

Function code	Name	Default	Min. unit	Setting range
FB-09	Quick run keep time	40s	1s	10~3000s
FB-10	Slow run keep time	60s	1s	10~3000s

NICE2000 control system has energy save function, which can make elevator run at quick/slow/stop conditions (refer to FB-16). When condition is switching, it can confirm the running time of NICE2000 under any work mode through FB-09 and FB-10.

FB-09 is high speed running keep time of elevator control system. FB-10 is only valid when quick and slow running is switching circularly: when quick running is over, and turn to slow running, if there are no passengers, it will come to stop state finally after the time of FB-10.

Function code	Name	Default	Min. unit	Setting range
FB-11	Runtime of reverse entering	20s	1s	0~30s

If NICE2000 control system is running in energy save mode, and there are passengers entering into elevator in reversed direction, the elevator will accelerate to high speed with buzzer ringing. If there are no passengers within the setting time, the elevator will run in energy save mode or stop running.

Function code	Name	Default	Min. unit	Setting range
FB-12	Assistant brake time	0.5s	0.1s	0.1~9.9S
FB-13	Brake open detect time	1.5s	0.1s	0.5~9.9S

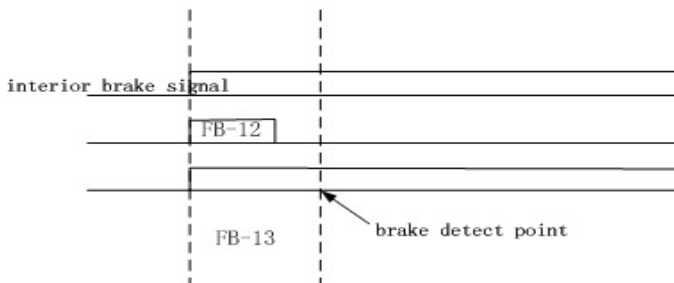

FB-12 and FB-13 are two parameters of NICE2000 to control the brake. FB-12 is functionary time of assistant brake output terminal. If after system output opening the brake, but the brake doesn't release after setting time (FB-13), it will export brake fault.

Fig 6-5 Brake output sequence chart

Function code	Name	Default	Min. unit	Setting range
FB-14	Examine stop delayed-time	1.5s	0.1s	0~9.9S

If the elevator drive mode is Y- Δ when in examine running, it may cause frequent start/stop of examine, and motor damage due to stop. Increasing FB-14 interval time can solve this problem. It should be done to prolong FB-14 time first after every stop, then enter the next examine.

Function code	Name	Default	Min. unit	Setting range
FB-15	Oil mode selection	0	1s	0~5

This function code is aiming to select oil mode according to different petrol pump.

0: The oil mode is not controlled by the controller and oil cycle time is determined by petro pump itself;1~5: This oil mode adapts to pulse petrol pump only, the setting value is pulse interval of pulse pump oil, and complete one cycle with parameters set by FB=06 and FB-07.

There are three main modes of petrol pump: 1) one is petrol pump with persistent electricity, whose oil time and cycle time are totally controlled by

itself, here FB-15 is set to 0; 2) this kind of pump will keep working once has electricity whose oil time and cycle time are controlled by the controller, here FB-16 is set to 0; 3) the last one can only work with pulse supply, whose oil time and cycle time are controlled by the controller.

For example: when the petrol pump is under pulse supply state, select FB-15=2/ FB-16=60/FB-07=4. It means that after continuous work for 48 hours, the elevator will carry through oil output with the mode “get electricity→1s→interval→2s→get electricity again→1s→interval→2s”, thus after the above cycle for 60s, it will stop oil finally. In this period, the pump gets supply for 20 times.

Function code	Name	Default	Min. unit	Setting range
FB-16	Energy save mode selection	2	1	0~3

0: Invalid

1: Quick stop cycle

When setting the elevator’s energy save mode, if there are no passengers after a period of time, the elevator will switch from high speed running to stop directly.

2: Quick/slow cycle

When setting the elevator’s energy save mode, if there are no passengers after a period of time, the elevator will switch from high speed running to slow speed running.

3: Quick/slow/stop cycle

When setting the elevator’s energy save mode, if there are no passengers after a period of time, the elevator will switch from high speed running to slow speed running first, and if still no passengers enter, the elevator will finally stop.

When NICE2000 is driving in Y- Δ running, its energy save mode can only be quick stop cycle; When in bypass convert frequency, FB-16 can select 1, 2 or3.

FB-16 is working together with input terminal “energy save selection” of NICE2000. The detailed combination and relative effect is in next table:

Energy save terminal	Energy save mode (FB-16)	Effect	Remark
Invalid	0, 1, 2, 3	No energy save	1)Elevator is at manual state;

Energy save terminal	Energy save mode (FB-16)	Effect	Remark
		effect	2)Running direction is determined by terminal “up” and “down”; 3)Keep high speed running after startup;
Avail	0	No energy save effect	1)Elevator is at automatic state; 2)Running direction is determined by terminal “up” and “down”; 3) Keep high speed running after startup;
Avail	1	Quick/stop cycle energy save	1)Elevator is at automatic state; 2)When FB-17=0, running direction is determined by terminal “up” and “down”; 3)When FB-17=1, running direction is determined by terminal “up photoelectricity” and “down photoelectricity”; 4)When elevator is in quick and stop state conversion, the corresponding state keep time is determined by quick keep time(FB-09)
Avail	2	Quick/slow cycle energy save	1)Elevator is at automatic state; 2)When FB-17=0, running direction is determined by terminal “up” and “down”; 3)When FB-17=1, running direction is determined by terminal “up photoelectricity” and “down photoelectricity”; but under this mode elevator will not stop, so the direction will not change; 4)When elevator is in quick and slow state conversion, the corresponding state keep time is determined by quick keep time(FB-09) and slow keep time (FB-10);

Energy save terminal	Energy save mode (FB-16)	Effect	Remark
Avail	3	Quick /slow /stop cycle energy save	1)Elevator is at automatic state; 2)When FB-17=0, running direction is determined by terminal “up” and “down”; 3)When FB-17=1, running direction is determined by terminal “up photoelectricity” and “down photoelectricity”; 4)When elevator is in quick, slow and stop state conversion, the corresponding state keep time is determined by quick keep time(FB-09) and slow keep time (FB-10);

Function code	Name	Default	Min. unit	Setting range
FB-17	Automatic function selection	0	1	0, 1

0: Half-automatic run mode. It means that elevator can only run in one direction. NICE2000 will decide the running direction of elevator according to input terminal signal.

This function is valid in energy-save mode when “FB-16≠0”. (FB-16: energy-save selection mode)

As to detailed information of running direction, refer to the next table:

Up signal	Down signal	Running direction of NICE2000	Remark
Avail	Invalid	Up direction	
Avail	Avail	Invalid	Stop running
Invalid	Invalid	Invalid	Stop running
Invalid	Avail	Down direction	

1: Complete automatic run mode. It means that elevator can run in both

directions. When elevator is in waiting state, the photoelectricity signal which acts first will determine the current running direction. For example: up photoelectricity valid indicates that there are passengers entering from underside, so the elevator will come upward; On the contrary, down photoelectricity valid means that there are passengers entering from downside, so the elevator will come downward. Under this mode, running direction will not be influenced by up/down direction, however, it need up/down signal to touch off to start up.

Function code	Name	Default	Min. unit	Setting range
FB-18	Y-△ switch time	3.0s	0.1s	0~9.9s

If NICE2000 is working under Y-△ control mode, FB-18 defines the required time from Y type to △ type.

Function code	Name	Default	Min. unit	Setting range
FB-19	Safety arrester action mode	0	1	0,1,2

0: Invalid

1: Continue work

2: Short time work

If elevator appears over-speed, reversion or drive-chain's disconnection phenomena, NICE2000 control system will carry through safety arrester control according to FB-19. User can make selection base to the characteristic of the safety arrester.

Function code	Name	Default	Min. unit	Setting range
FB-20	Safety arrester act keep time	4s	1	0~10s

If the action electromagnetic iron of safety arrester is working in short-time, FB-19 will select "2". At this time, NICE2000 will export output safety arrester act keep time of FB-20.

Function code	Name	Default	Min. unit	Setting range
FB-21	Comparison table of input and output			

In the next picture, every digital pipe has its own meaning (light on: input/output point is valid), detailed information is listed below:

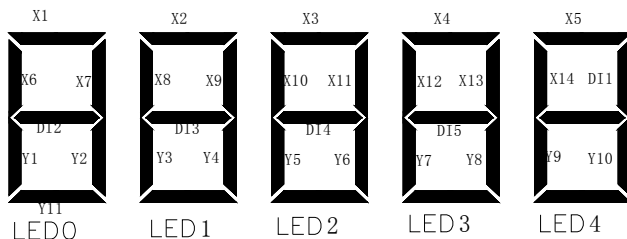

The input and output state is shown in above picture with specific meaning of every pipe lined out.

6.13 FC group Additional function parameters

FC-00	Sync switching point setting	default	300	Min. unit	1
	Setting range	200~2000			

it is used to set the convert freq. and work freq. switching coordinate point, the following function code FC-01 and FC-02 are based on FC-00 which is adjusting-free or at least set greater than (FC-04+10)

FC-01	Up switch delay	default	0ms	Min unit	1ms
	Setting range	0~700ms			

Used for the up switching point judgment, when the switching condition is ready and after this parameter time delay, the system shall switch from the convert freq. to work freq.

FC-02	Down switch delay	default	0ms	Min unit	1ms
	Setting range	0~700ms			

Used for the down switching point judgment, when the switching condition is ready and after this parameter time delay, the system shall switch from the convert freq. to work freq.

FC-03	Switch point coefficient	default	0	Min unit	1
	Setting range	0~12000			

This parameter is read-only which is used for check switching point coefficient, this switch value should not be too great when the running direction is same, and the error range should within 100(myriabit is neglectable)

FC-04	Switch coordinate point	default	0	Min unit	1
	Setting range	0~2000			

This parameter is read-only, switch the lowest point of sync signal, this point parameter must be smaller than FC-00 to assure the smooth switch, generally this parameter is set around 280.

FC-05	Sync signal cycle	default	0ms	Min unit	1ms
	Setting range	0~700ms			

This parameter is read-only, switch the sync signal changing cycle, generally is about 650ms.

New switch adjusting method

- 1 This parameter is only valid in bypass convert freq.
- 2: Switching method details see Fig 6-7 below

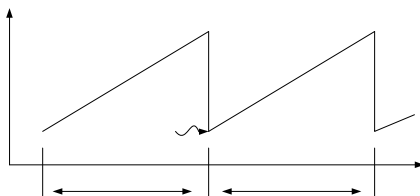

Fig 6-7 sync signal cycle

3 Firstly, choosing FC-01 or FC-02 for adjusting on the basis of running direction. Starting adjusting from 0 and add 100 each time (0, 100, 200, 300, 400, 500, 600 respectively) then select the best one. After this, done the fine tuning by add or reduce 20 to select the most appropriate parameter.

4 Judging the correctness of FC-03, FC-04, FC-05 (set the change of FC-03 at the same direction as criteria – changing range should smaller than 100). FC-04 should smaller than 300, FC-05 should around 650.

5 Please check F4-29, F4-30, F6-12, F6-13 or sync card wiring and sync card condition for FC-03, FC-04, FC-05 abnormal.

6.14 FF Group Factory parameter (reserved)

6.15 FP Group User parameter

Function code	Name	Default	Min. unit	Setting range
FP-00	User password	0	1	0~65535

Set it as any number except zero so that the password protection function is valid.

00000: eliminate the former user's password value and make password protect function invalid.

When user password is set and become effective, NICE2000 will forbid examining the parameter.

Please fix your password. If mis-setting or forget, please contact with factory.

Function code	Name	Default	Min. unit	Setting range
FP-01	Parameter update	0	1	0,1,2

0: No operation.

1: Inverter will resume all the parameters to factory default.

2: Inverter will eliminate the latest fault record.

Function code	Name	Default	Min. unit	Setting range
FP-02	User setting examine	0	1	0,1

After having selected FP-02 function, operating panel LED only display the parameter which is different from default in order to make it convenient for user to check up the setting and discover problems.

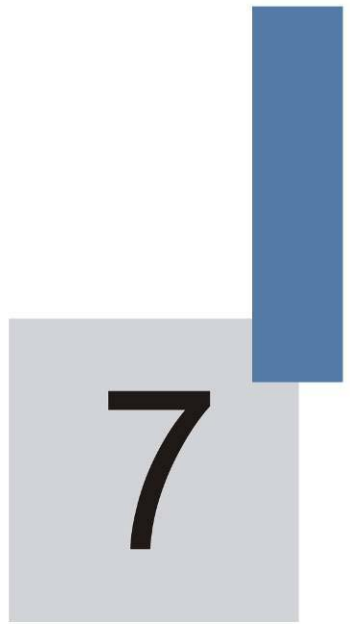

Typical application and adjusting of system

Chapter 7 Typical application and adjusting of system

7.1 Typical application of bypass variable frequency

Escalator bypass variable frequency technique is the combination of variable frequency drive and work frequency drive. The predominance of convert frequency drive is when startup and wait state, motor will shift smoothly with small current concussion, so that when there are few passengers, the escalator will running at slow speed. It not only can save energy but also can reduce mechanical abrasion. The advantage of direct electricity drive is calm speed running process, which use the simplest mode to achieve energy feedback without brake resistance. So bypass variable frequency is that take advantage of variable frequency drive into the variable speed process. If switch the drive motor to work frequency and prepare to enter rated speed running, inverter bypass will wait. In this process, inverter work for a short time so that save the system cost.

NICE2000 provides a suit of traditional Y- Δ standby control system besides bypass variable frequency control. With these two systems, it can reduce fault at largest extent.

NICE 2000 has combined the escalator controller and inverter together, providing user a special solvent. It not only can make full use of variable frequency and work frequency, but also can eliminate the brake energy save resistance. Energy save, low equipment cost and compact structure, all of these advantages are definitely the future trend of escalator development.

7.1.1 connection mode

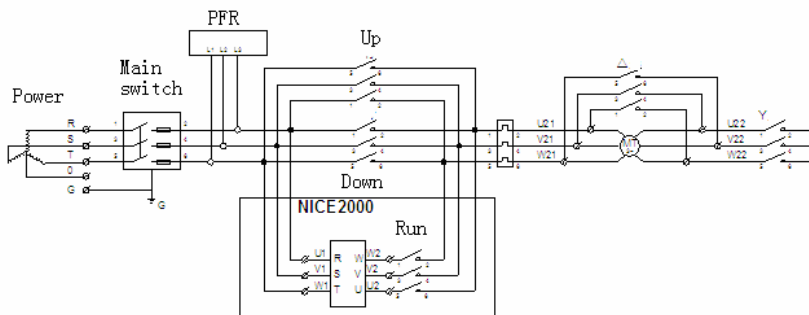

Fig 7.1 main circuit wiring

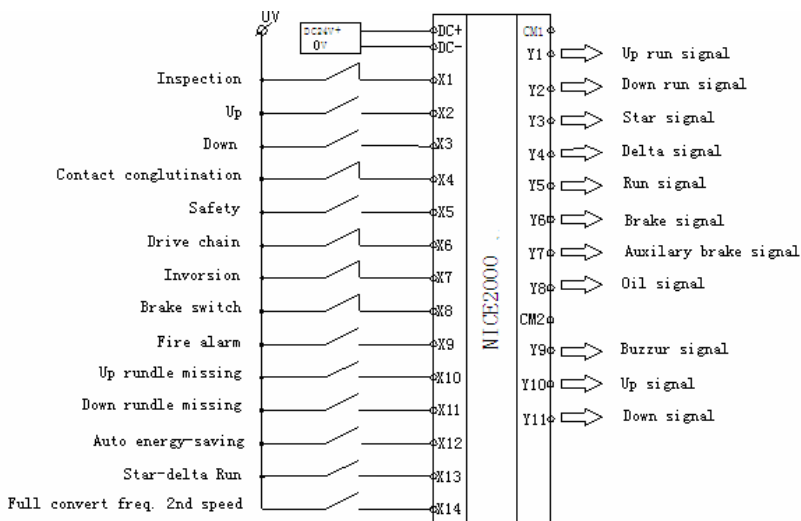

Fig 7-2 expansion board wiring

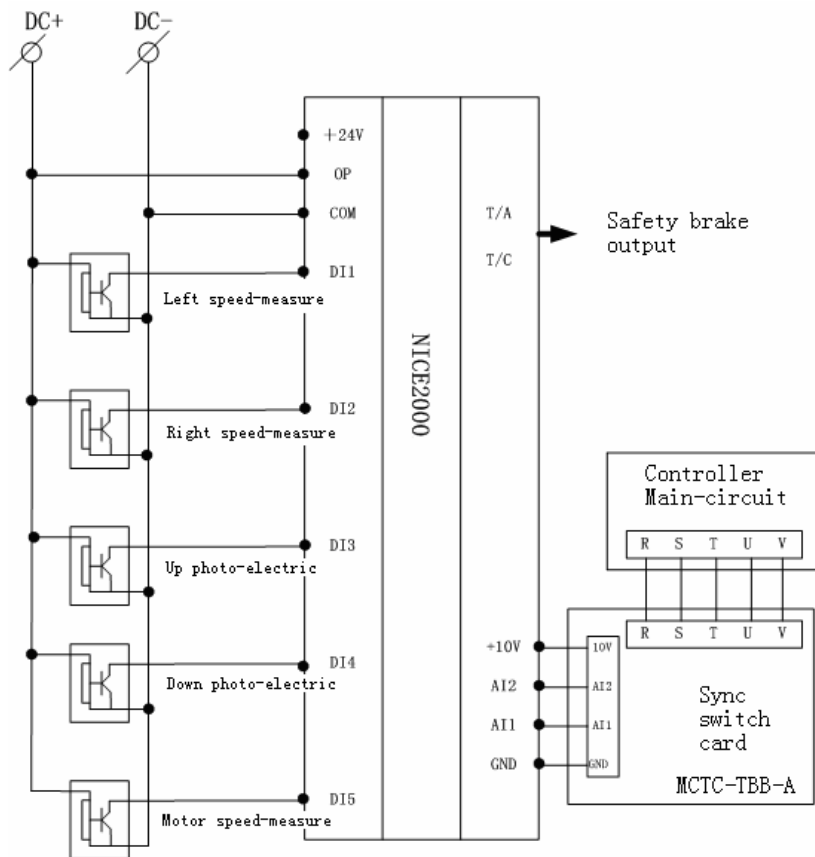

Fig 7.3 NICE2000 main board wiring (including synchronous switch card)

7.1.2 Parameter setting

Factory default of NICE2000 is set based upon bypass variable frequency parameter. So users just need to input the nameplate parameter to F1 group according to the actual motor configuration.

7.1.3 Running curve

In the bypass variable frequency control, the energy save running curve is shown in next picture:

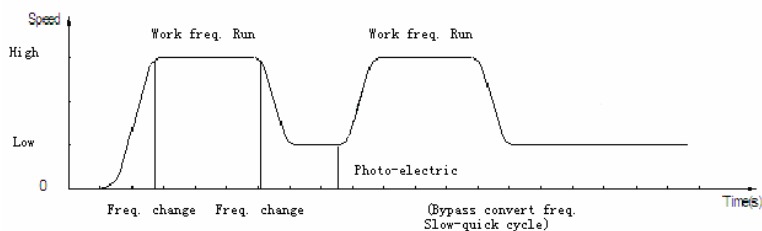

Fig 7.4 Quick/slow cycle energy save curve

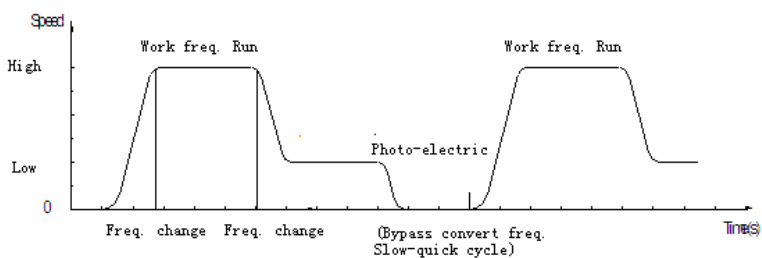

Fig 7.5 Quick/slow cycle energy save curve

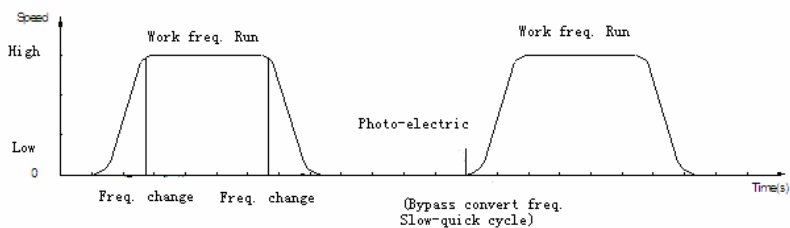

Fig 7.6 Quick stop cycle energy save curve

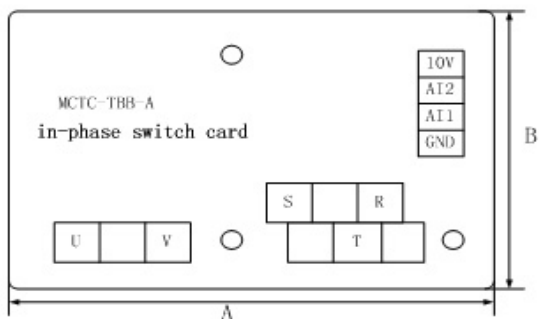

Fig 7.7 MCTC-TBB-A synchronous switch card

There are 7 input terminals on synchronous switch card (R,S,T,10V,AI1,AI2,GND) and 2 output terminals (U,V); among them, R,S,T,U,V contact to R,S,T,U,V on the inverter respectively.

7.2 Typical application of complete VF

Complete variable frequency is that the elevator is controlled by inverter in accelerate/decelerate/constant speed process. The difference is that when in constant speed, power supply of bypass variable frequency is driven by work frequency, while complete convert frequency is totally driven by convert frequency.

Complete variable frequency also can achieve multi-speed selection function. When input terminal “variable frequency speed selection” is valid, elevator will choose quick 2 frequency as aim frequency so that meet with different user requirement.

7.2.1 connection mode

System connection.

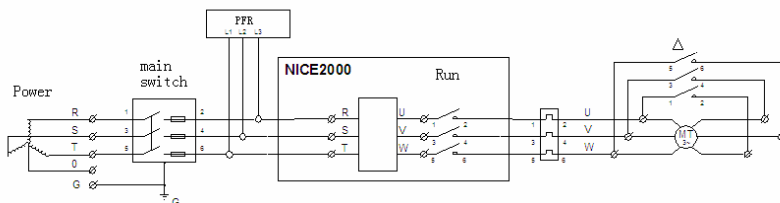

Fig 7.8 Complete variable frequency main circuit connection

Besides, terminal connection mode refers to Fig 7.2 and Fig 7.3.

7.2.2 Parameter setting

To set F0-01 to 2 means that complete variable frequency drive; then input the nameplate to group F1 parameter according to actual motor configuration.

7.2.3 running curve

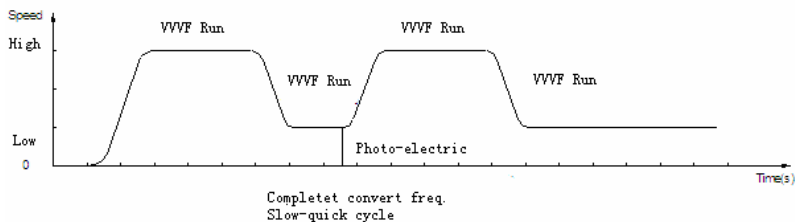

Fig 7.9 Complete variable frequency quick/slow cycle energy save curve

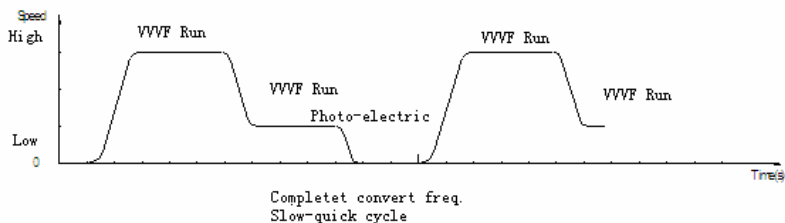

Fig 7.10 Complete variable frequency quick/slow stop energy save curve

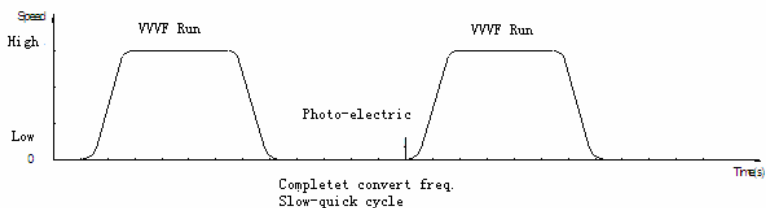

Fig 7.11 Complete variable frequency quick stop cycle energy save curve

7.3 Adjusting procedures



DANGER: Please make sure the escalator is in inspection running state and keep people away from it. Failure to follow this instruction will cause serious accident.

In order to be convenient for adjust, this chapter was written according to the normal sequence of lift adjustment. When the periphery circuit and machine installed are finished completely, you can finish the elevator's basic adjust.

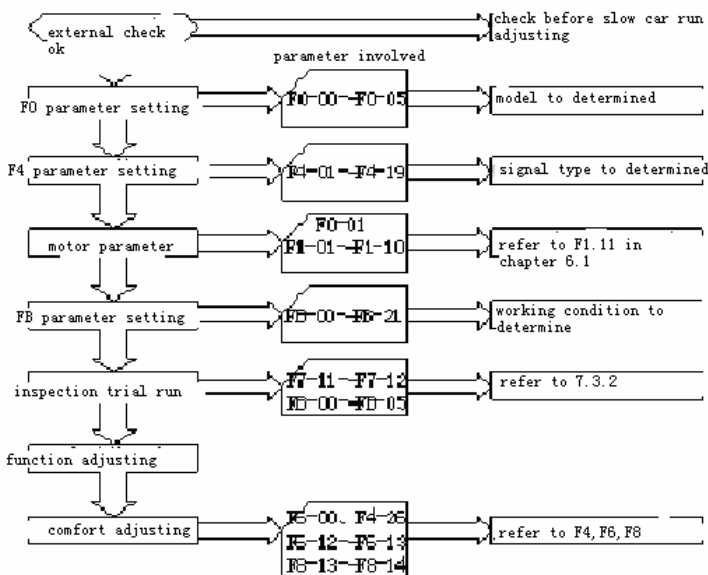

7.3.1 Check before slow state adjustment

Correct adjust is the safeguard of elevator's normal running. Before electric adjust, please check whether it is allowed to be adjusted and assure the spot safety. When adjusting, at least two workers should be on the spot, and cut off the power at once if abnormality happens.

- 1) Check mechanical and electric connection

Check periphery before electrify, in order to ensure human safety.

- a) Suitable component type.
 - b) Well connected safe circuit.
 - c) No person in elevator, and safe running condition.
 - d) Well grounded.
 - e) Correct periphery connection according to factory drawing.
 - f) Credible switch.
 - g) Check resistance between phases of main circuit, and judge whether connected to the earth.
 - h) Confirm that the elevator is in inspection state.
 - i) make sure that machine is installed correctly, and it will not damage to human and equipment.
- 2) Power check

It is necessary to check the power before electrify.

- a) The voltage between every two phases of user power should within the range of $380V \pm 15\%$, and imbalance range of each phase should be no more than 3%.
- b) The input voltage of interface terminal between DC+ and DC- is DC 24V.

Note: It will cause devastating result if the input voltage is over the allowed value; please check carefully. Please confirm positive and negative polarity of DC. Don't move the car if the system input power is in phase failure state.

3) Grounding check

Please check the electricity supply before the system is power on.

- a) Find out whether the resistance between grounding terminal and PE is infinite, if it is too small, check immediately.
 - Between R, S, T and PE
 - Between U1, V1, W1 and PE
 - Between motor U21, V21, W21, U22, V22, W22 and PE

- Between mainboard 24V and PE
 - Between terminal of safe circuit, inspection circuit and PE
- b) Find out whether the resistance between grounding terminal of all the electric part and power input PE is infinite, if it is too small, check immediately.

7.3.2 Adjustment

After checking the periphery, take off brake control wire, and turn the electricity on. Observe whether have output or not in the state of un-running; even if brake control wire is connected, brake can't be open as well, then cut off the power, and connect brake control wire. Prepare run at low speed.

1. Check after power-on

- 1) Make sure the input voltage (on main board) between CN2 +24V and COM is within range $DC24V \pm 0.5V$.
- 2) Make sure the voltage between DC+ and DC- terminal CN1 is 24V.

2. Setting function of terminal parameters check

Terminal function parameter group F4 and F5 will decide whether the received signal is correspondent with signal sent by system, and whether the expected aim is same with real aim.

- 1) Check whether the function of each setting terminal right according to the factory chart, and whether input/output terminal type is complied with the actual type.
- 2) Check out the corresponding input terminal signal is normal or not, through the numeral pipe on/off LED and input/output setting type of the corresponding terminal.

3. Motor tuning

Choose the keyboard running mode. Before motor tuning, please input parameter F1-00~F1-05; NICE2000 controller match standard based upon this nameplate.

4. Check test running

After above preparation, we can carry through test-run, and the inspection speed is set by F6-09 (default: 25Hz);

1) Input signal check

Check carefully whether the action sequence of the switch signals received is correct or not.(safety dot input signal, examine up/down input signal, touch conglutination signal, pre-reversion signal, brake opening signal etc.)

2) Output signal check

Check carefully whether the definition of MCB output terminal is corresponding to the relative contactor and whether the signal and the contact controlled by MCB output terminal work well. (Running contactor, brake contactor etc.)

3) Running direction check

Observe whether the actual direction is same with the aim direction (direction sign of motor flywheel is significant judgment); if not, please change two phases of motor randomly.

4) Sensor check

Main motor test speed sensor, left right speed sensor, up down step loss sensor are important guarantee for the normal running. If the running speed is abnormal, after sensor detecting abnormality signal, it will automatically cut off the running of the elevator. Observe carefully if sensor power light is normal or not, or survey if signal output terminal have voltage or not.

5. Check before high speed

On the basis of examine running, renew the escalator to normal state, and test running circs at hand and auto state separately, examine item by item according to the parameter setting.



Fault Diagnosis and Countermeasures

Chapter 8 Fault Diagnosis and Countermeasures

NICE2000 controller has about 40 pieces of alarm information or protection functions in total. The system controller monitors all kinds of input signal, run condition, exterior feedback information. If it abnormity happens, the relevant fault protection functions can react with fault code displayed.

8.1 Fault information and solutions

If fault alarm information is shown in the controller, the system will deal with the problem based on fault code. User can construe fault by suggestive information at this section, to find out fault cause and its resolvent.

Operate panel display	Fault description	Fault cause	Disposal way
Err01	Inverse unit protection	1.Main loop output is grounding or short wiring; 2.The connection of traction machine is too long; 3.Work condition is too hot; 4.The connections inside the controller become loose;	1.Obviate exterior problems such as connection; 2.Add reactor or output filter; 3.Inspect the wind channel and fan; 4.Please contact with agent or factory;
Err02	Accelerated over current	1.Main loop output is grounding or short wiring; 2.If the motor has done parameter tuning of not; 3.Load is too heavy;	1.Obviate exterior problems such as connection; 2.Motor parameter tuning; 3.Lighten sudden adding load;
Err03	Decelerated over current	1.Main loop output is grounding or short wiring; 2.If the motor has done parameter tuning of not; 3.Load is too heavy; 4.Decelerate curve is too steep;	1.Obviate exterior problems such as connection; 2.Motor parameter tuning; 3.Lighten sudden adding load; 4.Adjust the curve parameter;
Err04	Constant speed over current	1.Main loop output is grounding or short wiring; 2.If the motor has done parameter tuning of not;	1.Obviate exterior problems such as connection; 2.Motor parameter tuning; 3.Lighten sudden adding load;

Operate panel display	Fault description	Fault cause	Disposal way
		3.Load is too heavy; 4.Pulse wheel encoder interference is too strong;	4.Select proper encoder, and adopt shielded cable; 5. Properly increase F6-02.
Err05	Accelerated over voltage	1.Input voltage is too high; 2.Lift inverse pull is serious; 3.Brake resistance is too much, or brake unit is abnormal; 4.Accelerate curve is too steep;	1.Adjust input voltage; 2.Adjust the elevator startup time sequence; 3.Select proper brake resistance; 4.Adjust curve parameter;
Err06	Decelerated over voltage	1.Input voltage is too high; 2.Brake resistance is too much, or brake unit is abnormal; 3.Accelerate curve is too steep;	1.Adjust input voltage; 2.Select proper brake resistance; 3.Adjust curve parameter;
Err07	Constant speed over voltage	1.Input voltage is too high; 2.Brake resistance is too much, or brake unit is abnormal;	1.Adjust input voltage; 2.Select proper brake resistance;
Err08	Controller power fault	1.Input voltage is too high; 2.Drive control panel is abnormal;	1.Adjust input voltage; 2.Please contact with agent or factory;
Err09	Under voltage fault	1.Transient power cut exists; 2.Input voltage is too low; 3.Drive control panel is abnormal;	1.Obviate exterior problem of power; 2.Please contact with agent or factory;
Err 10	Inverter overload	1.Brake loop is abnormal; 2.Load is too heavy;	1.Inspect brake loop and power supply; 1.Lighten load;
Err 11	Motor overload	1.FC-02 setting is unsuitable; 2.Brake loop is abnormal; 3.Load is too heavy;	1.Adjust parameter; 2.Inspect brake loop and power supply;
Err 12	Input side phase	1.Input power asymmetry; 2.Diver control panel is	1.Adjust input power; 2.Please contact with agent or

Operate panel display	Fault description	Fault cause	Disposal way
	failure	abnormal;	factory;
Err 13	Output side phase failure	1.The connections of main loop output become loose; 2.Motor is broken;	1.Inspect connection; 2.Obviate motor fault;
Err 14	Module overheated	1.The temperature of working environment is too high; 2.The fan is broken; 3.The wind channel is blocked;	1.Reduce the environmental temperature; 2.Clear the wind channel; 3.Change the fan;
Err 15	Reserved		
Err 16	Reserved		
Err 17	Contactora fault	1.Bus voltage is abnormal; 2.Drive control panel is abnormal;	Please contact with agent or factory;
Err 18	Current detection fault	Diver control panel is abnormal;	Please contact with agent or factory;
Err 19	Motor tuning fault	1.Motor parameter setting is wrong; 2.Parameter tuning is overtime; 3.Synchronous rotate encoder is abnormal;	1.Input the right motor parameter; 2.Detect motor lead wire; 3.Detect the rotate encoder wiring, and make sure the pulse number per round is well set;
Err 20	Rotary encoder fault	1.Rotary encoder model is suited or not; 2.Encoder connection error;	1.Asynchronous motor can select push-pull output or open-collector encoders; synchronous motor can select UVW or SIN/COS; 2.Obviate connection problem;
Err 21	Data spillage	Data of encoder abnormality;	Please contact with agent or factory;
Err 22	Reserved		
Err 23	Short circuit fault to	Output short circuit to ground;	Please contact with agent or factory;

Operate panel display	Fault description	Fault cause	Disposal way
	ground		
Err 24~29	Reserved		
Err 30	Safety circuit off	The signal of safety circuit is cut.	1.Detect safety circuit, and look over its state; 2.Detect that exterior power supply is natural or not;
Err 31	Drive chain off	Drive chain is ruptured;	1.Check if the drive chain is ruptured. 2. Check if the drive chain protection act.
Err 32	Contact conglutination	Contact burn out the contact conglutination;	1.Check if the contact is burned out or not; 2. Check if the contact feedback switch gets stuck.
Err 33	Brake fault	Open brake fault;	1. Check if the brake can not open really. 2. Check if the brake protection switch cannot act.
Err 34	Left handrail speed abnormality	The speed of left handrail shows abnormality;	1.Check if the left handrail runs at abnormal speed; 2.Check if the left handrail speed test sensor works abnormal;
Err 35	Right handrail speed abnormality	The speed of right handrail shows abnormality;	1.Check if the right handrail runs at abnormal speed; 2.Check if the right handrail speed test sensor works abnormal;
Err 36	Up step loss	Up step loss;	1.Check if the up step running speed is abnormal, or lost; 2.Check if the up step loss sensor works abnormal;
Err 37	Down step loss	Down step loss;	1.Check if the down step running speed is abnormal, or

Operate panel display	Fault description	Fault cause	Disposal way
			lost; 2.Check if the down step loss sensor works abnormal;
Err 38	Mainframe speed test fault	The speed of mainframe is abnormal;	1.Check if the motor works well; 2.Check if the mainframe speed sensor works well;
Err 39	Anti-reverse fault	Prevent down running in up running process.	1.Check if reverse will happen in the up running process; 2.Check if anti-reverse switch work well;
Err 41	Motor speed tracker fault	When Δ running switch to variable frequency running, the tracking process intermits.	Properly reduce F6-02.

8.2 Common faults and disposal

The following faults may occur during the use of the inverter, please refer to the methods described below to perform the fault analysis:

- 1) No display after power-on
 - a) Check if the input power supply of the inverter is consistent with its rated voltage through multimeter. If there is something wrong, please remove it.
 - b) Check if three-phase rectifying bridge is intact. If the rectifying bridge has been exploded, please seek technical service.
 - c) Check if the CHARGE indicator is on. If the indicator is off, the fault will be in the rectifying bridge or the buffering resistance part. If the indicator is on, then the fault may be in the switch on/off part, please seek technical service.
- 2) Air switch trips off after power-on
 - a) Check if short circuit or grounding phenomenon exists in the input power.
 - b) Check if the rectifying bridge has been destroyed; if it is broken, seek professional help.
- 3) Motor's refusal to work after the inverter is running

- a) Check if there is balanced three-phase output between the U, V, and W. If there is, the motor wiring has been damaged, or the motor is blocked up due to mechanical cause.
 - b) There is output but three-phase is not balanced. It means that the inverter drive board or the output modules are damaged. Please seek help.
 - c) If there is no output, the inverter drive board or the output modules are damaged. Please seek help.
- 4) Inverter work normally after power on, but the air switch jump after running.
- a) Check if there is short circuit between output modules. If there is, seek help.
 - b) Check if there is short circuit or grounding between the motor wiring. If there is, seek help.
 - c) If tripping happens occasionally and the distance between motor and inverter is quite long, consider add output AC reactor.